

Техническая инструкция

MVS FDC II-S



DM-FDC540WMC/SF

DM-FDC600WMC/SF

DM-FDC660WMC/SF

DM-FDC720WMC/SF

DM-FDC790WMC/SF

DM-FDC850WMC/SF

DM-FDC920WMC/SF

DM-FDC970WMC/SF

СОДЕРЖАНИЕ

Часть 1 Общие сведения	3
Часть 2 Технические характеристики наружных блоков	16
Часть 3 Проектирование и монтаж системы	134

Часть 1

Общие сведения

1.	Производительность внутренних и наружных блоков	4
2.	Внешний вид	6
3.	Обозначение моделей	8
4.	Индекс производительности	10
5.	Процесс подбора	11

1. Производительность внутренних и наружных блоков

1.1 Внутренние блоки

1.1.1 Стандартные внутренние блоки

Таблица 1-1.1: Обозначения для стандартных внутренних блоков

Обозначение	Тип
Q1/DF	Однопоточный кассетный тип
Q2/DF	Двухпоточный кассетный тип
Q4/AF	Компактный четырёхпоточный кассетный тип
Q4/EF	Четырёхпоточный кассетный тип
T2/DBF,T2/BAF	Средненапорный канальный тип

Обозначение	Тип
T1/BF	Высоконапорный канальный тип
G/YMF	Настенный тип
DL/CF	Напольно-потолочный тип
F/AF(CF,EF)	Напольный тип
Z/DBF	Консольный тип

Таблица 1-1.2: Диапазон производительности стандартных внутренних блоков

Производительность		Показатель производительности	Q1/DF	Q2/DF	Q4/AF	Q4/EF	T2/BAF T2/DBF	T1/BF	G/YMF	DL/CF	F/AF (CF,EF)	Z/DBF
кВт	л.с.											
1,8	0,6	18	18	—	—	—	—	—	—	—	18	—
2,2	0,8	22	22	22	22	—	22	—	22	—	22	22
2,8	1	28	28	28	28	28	28	—	28	—	28	28
3,6	1,25	36	36	36	36	36	36	—	36	36	36	36
4,5	1,6	45	45	45	45	45	45	—	45	45	45	45
5,6	2	56	56	56	—	56	56	—	56	56	56	—
7,1	2,5	71	71	71	—	71	71	71	71	71	71	—
8,0	3	80	—	—	—	80	80	80	80	80	80	—
9,0	3,2	90	—	—	—	90	90	90	90	90	90	—
10,0	3,6	100	—	—	—	100	—	—	—	—	—	—
11,2	4	112	—	—	—	112	112	112	—	112	—	—
14,0	5	140	—	—	—	140	140	140	—	140	—	—
16,0	6	160	—	—	—	—	—	160	—	160	—	—
20,0	7	200	—	—	—	—	—	200	—	—	—	—
25,0	9	250	—	—	—	—	—	250	—	—	—	—
28,0	10	280	—	—	—	—	—	280	—	—	—	—
40,0	14	400	—	—	—	—	—	400	—	—	—	—
45,0	16	450	—	—	—	—	—	450	—	—	—	—
56,0	20	560	—	—	—	—	—	560	—	—	—	—

1.1.2 Блок со 100% притоком свежего воздуха

Таблица 1-1.3: Диапазон производительности блоков со 100% притоком свежего воздуха

Производительность	12,5кВт	14кВт	20кВт	25кВт	28кВт
Показатель производительности	125	140	200	250	280

1.2 Приточно-вытяжная установка с рекуперацией тепла

Таблица 1-1.4: Диапазон производительности приточно-вытяжной установки с рекуперацией тепла

Производительность	200м ³ /ч	300м ³ /ч	400м ³ /ч	500м ³ /ч	800м ³ /ч	1000м ³ /ч	1500м ³ /ч	2000м ³ /ч
--------------------	----------------------	----------------------	----------------------	----------------------	----------------------	-----------------------	-----------------------	-----------------------

1.3 Наружные блоки

Таблица 1-1.5: Диапазон производительности наружных блоков

Производительность	Наименование модели
18 л.с.	DM-FDC540WMC/SF
20 л.с.	DM-FDC600WMC/SF
22 л.с.	DM-FDC660WMC/SF
24 л.с.	DM-FDC720WMC/SF
26 л.с.	DM-FDC790WMC/SF
28 л.с.	DM-FDC850WMC/SF
30 л.с.	DM-FDC920WMC/SF
32 л.с.	DM-FDC970WMC/SF

Примечание:

1. Наружные блоки серии MVS Individual Series (FDC II-S) не могут комбинироваться.

2. Внешний вид

2.1 Внутренние блоки

2.1.1 Стандартные внутренние блоки

Таблица 1-2.1: Внешний вид стандартных внутренних блоков

<p>Однопоточный кассетный тип Q1/DF</p> 	<p>Двухпоточный кассетный тип Q2/DF</p> 
<p>Компактный четырёхпоточный кассетный тип Q4/AF</p> 	<p>Четырёхпоточный кассетный тип Q4/EF</p> 
<p>Средненапорный канальный тип T2/DBF T2/BAF</p> 	<p>Высоконапорный канальный тип T1/BF</p> 
<p>Настенный тип G/YMF</p> 	<p>Напольно-потолочный тип DL /CF</p> 
<p>Напольный тип F/AF(CF,EF)</p> 	<p>Консольный тип Z/DBF</p> 

2.1.2 Блок со 100% притоком свежего воздуха

Таблица 1-2.2: Внешний вид блоков со 100% притоком свежего воздуха

<p>Блок со 100% притоком свежего воздуха FA</p> 

2.2 Приточно-вытяжная установка с рекуперацией тепла

Таблица 1-2.3: Внешний вид приточно-вытяжной установки с рекуперацией тепла

<p>Приточно-вытяжная установка с рекуперацией тепла</p> 

2.3 Наружные блоки

Таблица 1-2.4: Внешний вид наружных блоков

18 л.с. (одновентиляторный)	20/22 л.с. (двухвентиляторный)	24/26/28/30/32 л.с. (двухвентиляторный)
		

3. Обозначение моделей

3.1 Внутренние блоки

3.1.1 Стандартные внутренние блоки

D M - DP 056 Q4 / E F

① ② ③ ④ ⑤ ⑥ ⑦

Обозначение		
№.	Код	Расшифровка
1	D	Dantex
2	M	VRF
3	DP	Серия MVS UNI
4	056	Показатель производительности (производительность в кВт, умноженная на 10)
5	Q1	Тип внутреннего блока Q1: Одноточный кассетный тип Q2: Двухпоточный кассетный тип Q4: Четырёхпоточный кассетный тип T2: Средненапорный канальный тип T1: Высоконапорный канальный тип G: Настенный тип DL: Напольно-потолочный тип F: Напольный тип Z: Консольный тип
6	E	Серия E
7	F	Тип хладагента: R410A

3.1.2 Блок со 100% притоком свежего воздуха

D M - DP 280 T1 / N A F

① ② ③ ④ ⑤ ⑥ ⑦ ⑨

Обозначение		
№.	Код	Примечание
1	D	Dantex
2	M	VRF
3	DP	DP
4	280	Показатель производительности (производительность в кВт, умноженная на 10)
5	T1	Тип внутреннего блока T1: Высоконапорный канальный тип
6	N	Блок со 100% притоком свежего воздуха
7	A	Серия A
8	F	Тип хладагента: R410A

3.2 Наружные блоки

D M - FDC 660 W M C / S F

① ② ③ ④ ⑤ ⑥ ⑦ ⑧ ⑨

Обозначение		
№.	Код	Примечание
1	D	Dantex
2	M	VRF
3	FDC	Тип компрессоров: FDC Inverter - Full DC Inverter
4	660	Показатель производительности (производительность в кВт, умноженная на 10)
5	W	Категория блока (W: наружный блок)
6	M	Серия M - (II поколение)
7	C	Категория серии (C: индивидуальное исполнение)
8	S	Электропитание 380-415 В, 3 Ф, 50 Гц
9	F	Тип хладагента: R410A

4. Индекс производительности

$$\text{Индекс производительности} = \frac{\text{Сумма показателей производительности внутренних блоков}}{\text{Показатель производительности наружного блока}}$$

Таблица 1-4.1: Комбинационное соотношение внутренних и наружных блоков

Тип	Минимальное комбинационное соотношение	Максимальное комбинационное соотношение		
		Только стандартные внутренние блоки	Только блоки со 100% притоком свежего воздуха	Блоки со 100% притоком свежего воздуха и стандартные внутренние блоки
Серия наружных блоков V6-i	50%	130%	100%	100% ¹

Примечание:

1. При одновременном монтаже блоков со 100% притоком свежего воздуха и стандартных внутренних блоков полная производительность первых не должна превышать 30% от производительности наружного блока, а комбинационное соотношение не должно превышать 100%.

Таблица 1-4.2: Соотношение производительности внутренних и наружных блоков

Производительность наружного блока			Сумма показателей производительности подключённых внутренних блоков (Только стандартные внутренние блоки)	Сумма показателей производительности подключённых внутренних блоков (блоки со 100% притоком свежего воздуха и стандартные внутренние блоки)	Максимальное количество подключённых внутренних блоков
кВт	л.с.	Показатель производительности			
25,2	8	252	от 126 до 327,6	от 126 до 252	13
28,0	10	280	от 140 до 364	от 140 до 280	16
33,5	12	335	от 167,5 до 435,5	от 167,5 до 335	20
40,0	14	400	от 200 до 520	от 200 до 400	23
45,0	16	450	от 225 до 585	от 225 до 450	26
50,0	18	500	от 250 до 650	от 250 до 500	29
56,0	20	560	от 280 до 728	от 280 до 560	33
61,5	22	615	от 307,5 до 799,5	от 307,5 до 615	36
67,0	24	670	от 335 до 871	от 335 до 670	39
73,0	26	730	от 365 до 949	от 365 до 730	43
78,5	28	785	от 392,5 до 1020,5	от 392,5 до 785	46
85,0	30	850	от 425 до 1105	от 425 до 850	50
90,0	32	900	от 450 до 1170	от 450 до 900	53

5. Процесс подбора

5.1 Описание процесса подбора

Этап 1: Условия проектирования

Расчётная температура и влажность (в помещении и снаружи помещения)
Тепловая нагрузка, требуемая для каждого помещения
Максимальная нагрузка системы
Длина трубопровода, перепад высот
Технические характеристики внутреннего блока (тип и кол-во)

Этап 2: Подбор внутренних блоков

Определите коэффициент безопасности внутреннего блока

Выберите модели внутренних блоков, убедившись в обеспечении следующих условий:
Производительность внутреннего блока, скорректированная в соответствии с температурой в помещении
 $WB^1 \geq \text{Требуемая тепловая нагрузка} \times \text{Коэффициент безопасности внутреннего блока}$

Этап 3: Подбор наружных блоков

Определите требуемую полную тепловую нагрузку на наружный блок

Определите сумму максимальных нагрузок во всех помещениях

Определите максимальную нагрузку системы

Предварительно выберите производительность наружного блока на основании индекса производительности

Убедитесь, что количество внутренних блоков, подключённых к наружному блоку, соответствует норме

Скорректируйте холодо- и теплопроизводительность наружного блока в соответствии со следующими параметрами:
Температура наружного воздуха / Температура в помещении WB / Индекс производительности / Длина трубопровода, перепад высот / Потери тепла в трубопроводе / Обмерзание (только для теплопроизводительности)

Скорректированная производительность наружного блока \geq Требуемая полная тепловая нагрузка на наружный блок

Нет

Подбор VRF системы завершён

Примечание:

1. Если расчётная температура соответствует значениям температуры, указанным в Таблице производительности внутренних блоков, рассчитайте скорректированную производительность методом интерполяции. Если подбор внутренних блоков осуществляется на основании полной и явной тепловых нагрузок, подбирайте внутренние блоки с учётом обеих нагрузок, требуемых для каждого помещения. Явная теплопроизводительность внутренних блоков, аналогично полной, должна быть скорректирована в соответствии с температурой в помещении - при необходимости методом интерполяции. Таблицы производительности внутренних блоков см. в соответствующем техническом руководстве для внутренних блоков.

MVS FDC II-S

5.2 Образец

Ниже представлен образец подбора на основании полной тепловой нагрузки на охлаждение.

Рисунок 1-5.1: План помещения

Помещение А	Помещение Н	Помещение G	Помещение F
Помещение В	Помещение С	Помещение D	

Этап 1: Условия проектирования

- Температура в помещении +25 °C DB, +18 °C WB; температура наружного воздуха +33 °C DB.
- Определите значения максимальной нагрузки для каждого помещения и системы в целом. Как показано в Таблице 1-5.1, максимальная нагрузка системы составляет 50,7 кВт.

Таблица 1-5.1: Тепловая нагрузка, требуемая для каждого помещения (кВт)

Время	Помеще-ние А	Помеще-ние В	Помеще-ние С	Помеще-ние D	Помеще-ние E	Помеще-ние F	Помеще-ние G	Помеще-ние Н	Всего
9:00	4.8	4.8	3.0	3.0	9.1	9.0	2.9	2.9	39.5
12:00	6.6	7.1	5.1	5.1	7.4	6.8	4.0	4.0	46.1
14:00	9.0	9.4	4.9	4.9	7.3	6.8	4.2	4.2	50.7
16:00	10.6	10.7	3.9	3.9	6.3	6.2	3.8	3.8	49.2

- Максимальная длина трубопровода и перепад высот для данного образца представлены на Рисунке 1-5.2.

Рисунок 1-5.2: Схема системы



- Тип внутреннего блока во всех помещениях: Средненапорный канальный тип (T2).

Этап 2: Подбор внутренних блоков

- В данном образце не учитывается коэффициент безопасности (т.е. коэффициент безопасности равен 1).
- Выберите модели внутренних блоков, ориентируясь на Таблицу холодопроизводительности для блоков средненапорного канального типа. Скорректированная производительность каждого внутреннего блока должна быть выше или равна максимальной нагрузке, предусмотренной для соответствующего помещения. Выбранные внутренние блоки показаны в Таблице 1-5.3.

Таблица 1-5.2: Отрывок из Таблицы холодопроизводительности для блоков средненапорного канального типа (T2)

Модель	Показатель производительности	Температура в помещении													
		14°C WB		16°C WB		18°C WB		19°C WB		20°C WB		22°C WB		24°C WB	
		20°C DB		23°C DB		26°C DB		27°C DB		28°C DB		30°C DB		32°C DB	
		TC	SHC	TC	SHC	TC	SHC	TC	SHC	TC	SHC	TC	SHC	TC	SHC
T2	22	1.5	1.4	1.8	1.5	2.1	1.6	2.2	1.6	2.3	1.7	2.4	1.5	2.4	1.5
	28	1.9	1.7	2.3	1.9	2.6	2.1	2.8	2.1	3.0	2.1	3.1	2.0	3.1	1.9
	36	2.5	2.1	2.9	2.3	3.4	2.5	3.6	2.6	3.8	2.7	4.2	2.8	3.9	2.3
	45	3.1	2.6	3.7	2.8	4.2	3.1	4.5	3.2	4.8	3.2	4.9	3.1	5.1	2.9
	56	3.9	3.0	4.6	3.3	5.3	3.6	5.6	3.7	5.9	3.8	6.2	3.7	6.2	3.4
	71	4.9	3.9	5.8	4.3	6.7	4.7	7.1	4.9	7.5	4.8	7.8	4.6	7.8	4.3
	80	5.5	4.4	6.6	4.9	7.5	5.3	8.0	5.5	8.4	5.5	8.8	5.2	8.8	4.8
	90	6.2	5.3	7.3	5.8	8.4	6.3	9.0	6.4	9.6	6.5	9.9	6.1	9.9	5.7
	112	7.7	6.4	9.1	7.1	10.5	7.7	11.2	7.8	11.9	8.1	12.5	7.8	12.5	7.4
	140	9.7	7.8	11.3	8.6	13.2	9.6	14.0	9.8	14.8	9.8	15.7	9.7	15.4	8.8

Обозначения:

ТС: Полная производительность (кВт);

SHC: Явная теплопроизводительность (кВт)

Таблица 1-5.3: Выбранные внутренние блоки

	Помещение А	Помещение В	Помещение С	Помещение D
Максимальная тепловая нагрузка (кВт)	10,6	10,7	5,1	5,1
Выбранный внутренний блок	DM-DP140T2/BAF	DM-DP140T2/BAF	DM-DP056T2/BAF	DM-DP056T2/BAF
Скорректированная ТС (кВт)	13,2	13,2	5,3	5,3
	Помещение E	Помещение F	Помещение G	Помещение H
Максимальная тепловая нагрузка (кВт)	9,1	9,0	4,2	4,2
Выбранный внутренний блок	DM-DP112T2/BAF	DM-DP112T2/BAF	DM-DP045T2/BAF	DM-DP045T2/BAF
Скорректированная ТС (кВт)	10,5	10,5	4,2	4,2

Этап 3: Подбор наружных блоков

- Определите требуемую полную тепловую нагрузку на наружный блок со стороны внутренних блоков на основании суммы максимальных нагрузок во всех помещениях или максимальной нагрузки системы. В данном образце расчёт нагрузки осуществлён на основании максимальной нагрузки системы. Таким образом, требуемая тепловая нагрузка составляет 50,7 кВт.
- Предварительно выберите наружный блок на основании суммы показателей производительности выбранных внутренних блоков (CIs) (как показано в Таблице 1-5.4), убедившись, что комбинационное соотношение находится в пределах 50% - 130%. См. Таблицу 1-5.5. Поскольку сумма показателей производительности внутренних блоков (CIs) равна 706, наружные блоки производительностью от 20 л.с. до 32 л.с. потенциально подходят. Начните выбор с наружного блока с наименьшей производительностью – 20 л.с.

Таблица 1-5.4: Сумма показателей производительности внутренних блоков

Модель	Показатель производительности	Количество блоков
DM-DP140T2/BAF	140	2
DM-DP112T2/BAF	112	2
DM-DP056T2/BAF	56	2
DM-DP045T2/BAF	45	2

Сумма показателей производительности (CIs)	706
---	------------

Таблица 1-5.5: Отрывок из Таблицы 1-5.2 Комбинации внутренних и наружных блоков

Производительность наружного блока			Сумма показателей производительности подключённых внутренних блоков (Только стандартные внутренние блоки)	Максимальное количество подключённых внутренних блоков
кВт	л.с.	Показатель производительности		
50,0	18	500	от 250 до 650	29
56,0	20	560	от 280 до 728	33
61,5	22	615	от 307,5 до 799,5	36
67,0	24	670	от 335 до 871	39
73,0	26	730	от 365 до 949	43
78,5	28	785	от 392,5 до 1020,5	46
85,0	30	850	от 425 до 1105	50
90,0	32	900	от 450 до 1170	53

- Количество подключённых внутренних блоков – 8 шт. Максимальное количество внутренних блоков для подключения к наружному блоку производительностью 20 л.с. - не более 33 шт. Таким образом, количество подключённых внутренних блоков соответствует норме.
- Рассчитайте скорректированную производительность наружного блока:
 - а) Сумма показателей производительности внутренних блоков (CIs) равна 706. Показатель производительности (CI) наружного блока DM-FDC600WMC/SF производительностью 20 л.с. равен 560. Таким образом, комбинационное соотношение составляет $706 / 560 = 126\%$.
 - б) Ориентируясь на Таблицу холодопроизводительности наружного блока, методом интерполяции рассчитайте производительность ("B"), скорректированную в соответствии с температурой наружного воздуха, температурой в помещении и комбинационным соотношением. См. Таблицы 1-5.6 и 1-5.7.

Таблица 1-5.6: Отрывок из Таблицы холодопроизводительности 2-8.7 для модели DM-FDC600WMC/SF

CR	Температура наружного воздуха (°C DB)	Температура в помещении (°C DB / °C WB)	
		25,8 / 18,0	
		TC	PI
		кВт	кВт
130%	31	61,3	14,33
	33	60,4	14,88
	35	59,5	15,46
120%	31	60,2	13,88
	33	59,3	14,44
	35	58,4	15,00

Таблица 1-5.7: Холодопроизводительность, рассчитанная методом интерполяции

CR	Температура наружного воздуха (°C DB)	Температура в помещении (°C DB / °C WB)	
		25,8 / 18,0	
		TC	PI
		кВт	кВт
130%			
	33	60,4	14,88
	B = 60¹		
120%			
	33	59,3	14,44

Примечание:

1. $59,3 + (60,4 - 59,3) \times (126 - 120) / (130 - 120) = 60$.

с) Определите поправочный коэффициент длины трубопровода и перепада высот ("K1")

Рисунок 1-5.3: Скорость изменения холодопроизводительности V6-i

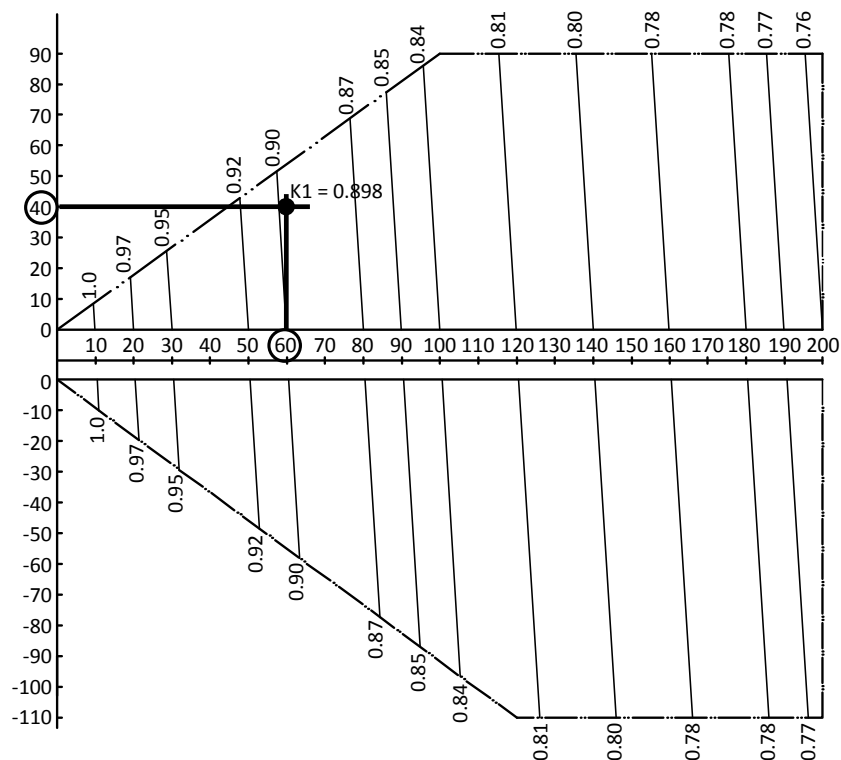

Примечание:

1. Горизонтальная ось обозначает эквивалентную длину трубопровода от самого удаленного внутреннего блока до первого разветвителя наружного блока; вертикальная ось обозначает максимальный перепад высот между внутренним и наружным блоками: положительные значения указывают, что наружный блок находится над внутренним блоком, а отрицательные значения указывают, что наружный блок находится под внутренним блоком.

d) Рассчитайте скорректированную производительность для MV6-i560WV2GN1 ("C"), используя K1:

$$C = V \times K_1 = 60 \times 0.898 = 53.8 \text{ кВт}$$

- Скорректированная производительность 53.8 кВт выше требуемой полной тепловой нагрузки 50,7 кВт, следовательно, подбор осуществлён правильно. (Если скорректированная производительность ниже требуемой полной тепловой нагрузки, повторно пройдите процесс подбора наружных блоков (Этап 3) с пункта предварительного выбора производительности наружного блока).

Часть 2

Технические

характеристики наружных

блоков

1.	Технические характеристики	17
2.	Габаритные размеры	19
3.	Пространство для монтажа	22
4.	Схема холодильного контура	23
5.	Электрическая схема	28
6.	Электрические характеристики	30
7.	Функциональные компоненты и устройства защиты	31
8.	Таблицы производительности	32
9.	Диапазон рабочих температур	130
10.	Уровень звукового давления	131
11.	Принадлежности	133

1. Технические характеристики

18-22л.с.

Таблица 2-1.1: Технические характеристики блоков производительностью 18-22 л.с.

Производительность, л.с			18	20	22	24
Модель			DM-FDC540WMC/SF	DM-FDC600WMC/SF	DM-FDC660WMC/SF	DM-FDC720WMC/SF
Электропитание		В/Ф/Гц	380-415/3/50(60)			
Охлаждение ¹	Производительность	кВт	50,0	56,0	61,5	67,0
		кБте/ч	170,6	191,1	209,8	228,6
	Потребляемая мощность	кВт	14,7	16,0	20,2	21,6
		EER	3,40	3,50	3,05	3,10
Обогрев ²	Производительность	кВт	50,0	56,0	61,5	67,0
		кБте/ч	170,6	191,1	209,8	228,6
	Потребляемая мощность	кВт	12,2	13,8	17,6	16,8
		COP	4,10	4,05	3,50	4,00
Подключённые внутренние блоки	Полная производительность		50-130% от производительности наружного блока			
	Максимальное количество		29	33	36	39
Компрессор	Тип		DC инвертор			
	Количество		1		2	
	Тип холодильного масла		FV68H			
	Способ запуска		Плавный			
Вентилятор	Тип		Пропеллерный			
	Тип двигателя		Двигатель постоянного тока			
	Количество		1		2	
	Мощность на выходе двигателя	кВт	0,92	0,56×2	0,56×2	0,92×2
	Расход воздуха	м ³ /ч	13000	17000	17000	25000
	Тип привода		Прямой			
Хладагент	Тип		R410A			
	Заводская заправка	кг	13	17	17	22
Соединения трубопроводов ³	Жидкостный трубопровод	мм	Φ19,1	Φ19,1		
	Газовый трубопровод	мм	Φ31,8	Φ31,8		
Уровень звукового давления ⁴		дБ(А)	62	63		64
Габаритные размеры без упаковки(Ш×В×Г)		мм	1340×1635×850	1340×1635×825		1730×1830×850
Габаритные размеры в упаковке(Ш×В×Г)		мм	1405×1805×910			1800×2000×910
Вес без упаковки		кг	295	344	344	407
Вес в упаковке		кг	322	364	364	430
Диапазон рабочих температур	Охлаждение	°С	-5 ~ +54			
	Обогрев	°С	-25 ~ +24			

Примечание:

1. Температура в помещении +27 °С по сухому термометру, +19 °С по влажному термометру; Температура наружного воздуха +35 °С по сухому термометру; эквивалентная длина трубопровода хладагента составляет 7,5 м, перепад высот 0 м.
2. Температура в помещении +20 °С по сухому термометру; Температура наружного воздуха +7 °С по сухому термометру, +6 °С по влажному термометру; эквивалентная длина трубопровода хладагента составляет 7,5 м, перепад высот 0 м.
3. Указанные диаметры соответствуют с диаметру труб запорных вентиляей.
4. Значения звукового давления измерены в полубезэховой лаборатории на расстоянии 1 м от фронтальной стороны блока и 1,3 м от пола.

MVS FDC II-S

24-32 л.с.

Таблица 2-1.2: Технические характеристики блоков производительностью 24-32 л.с.

Производительность, л.с.		26	28	30	32	
Модель		DM-FDC790WMC/SF	DM-FDC850WMC/SF	DM-FDC920WMC/SF	DM-FDC970WMC/SF	
Электропитание		В/Ф/Гц				
		380-415/3/50(60)				
Охлаждение ¹	Производительность	кВт	73,0	78,5	85,0	90,0
		кБте/ч	249,1	267,8	290,0	307,1
	Потребляемая мощность	кВт	21,6	24,9	28,3	32,1
		EER	3,40	3,15	3,00	2,80
Обогрев ²	Производительность	кВт	73,0	78,5	85,0	90,0
		кБте/ч	249,1	267,8	290,0	307,1
	Потребляемая мощность	кВт	18,1	21,8	24,3	26,5
		COP	4,05	3,60	3,50	3,40
Подключённые внутренние блоки	50-130% от производительности наружного блока					
		43	46	50	53	
Компрессор	Тип	DC инвертор				
	Количество	2				
	Тип холодильного масла	FV68H				
	Способ запуска	Плавный				
Вентилятор	Тип	Пропеллерный				
	Тип двигателя	Двигатель постоянного тока				
	Количество	2				
	Мощность на выходе двигателя	кВт	0,92×2	0,92×2	0,92×2	0,92×2
		Расход воздуха	м ³ /ч	25000	25000	24000
	Тип привода	Прямой				
Хладагент	Тип	R410A				
	Заводская заправка	кг	22	22	25	25
Соединения трубопроводов ³	Жидкостный трубопровод	мм	Φ22,2		Φ22,2	
	Газовый трубопровод	мм	Φ31,8		Φ38,1	
Уровень звукового давления ⁴		дБ(А)	64			
Габаритные размеры без упаковки(Ш×В×Г)		мм	1730 × 1830 × 850			
Габаритные размеры в упаковке(Ш×В×Г)		мм	1800×2000×910			
Вес без упаковки		кг	429		475	
Вес в упаковке		кг	452		507	
Диапазон рабочих температур	Охлаждение	°С	-5 ~ +54			
	Обогрев	°С	-25 ~ +24			

Примечание:

1. Температура в помещении +27 °С по сухому термометру, +19 °С по влажному термометру; Температура наружного воздуха +35 °С по сухому термометру; эквивалентная длина трубопровода хладагента составляет 7,5 м, перепад высот 0 м.
2. Температура в помещении +20 °С по сухому термометру; Температура наружного воздуха +7 °С по сухому термометру, +6 °С по влажному термометру; эквивалентная длина трубопровода хладагента составляет 7,5 м, перепад высот 0 м.
3. Указанные диаметры соответствуют с диаметру труб запорных вентилялей.
4. Значения звукового давления измерены в полубезэховой лаборатории на расстоянии 1 м от фронтальной стороны блока и 1,3 м от пола.

2. Габаритные размеры

18 л.с. Рисунок 2-2.2: Габаритные размеры блоков производительностью 18 л.с. (Единица измерения: мм)



Таблица 2-2.2: Диаметр соединительного трубопровода для блоков производительностью 18 л.с. (Единица измерения: мм)

Типоразмер	14 л.с.	16 л.с.	18 л.с.
A	Φ15,9	Φ15,9	Φ19,1
B	Φ31,8	Φ31,8	Φ31,8

MVS FDC II-S

20/22 л.с.

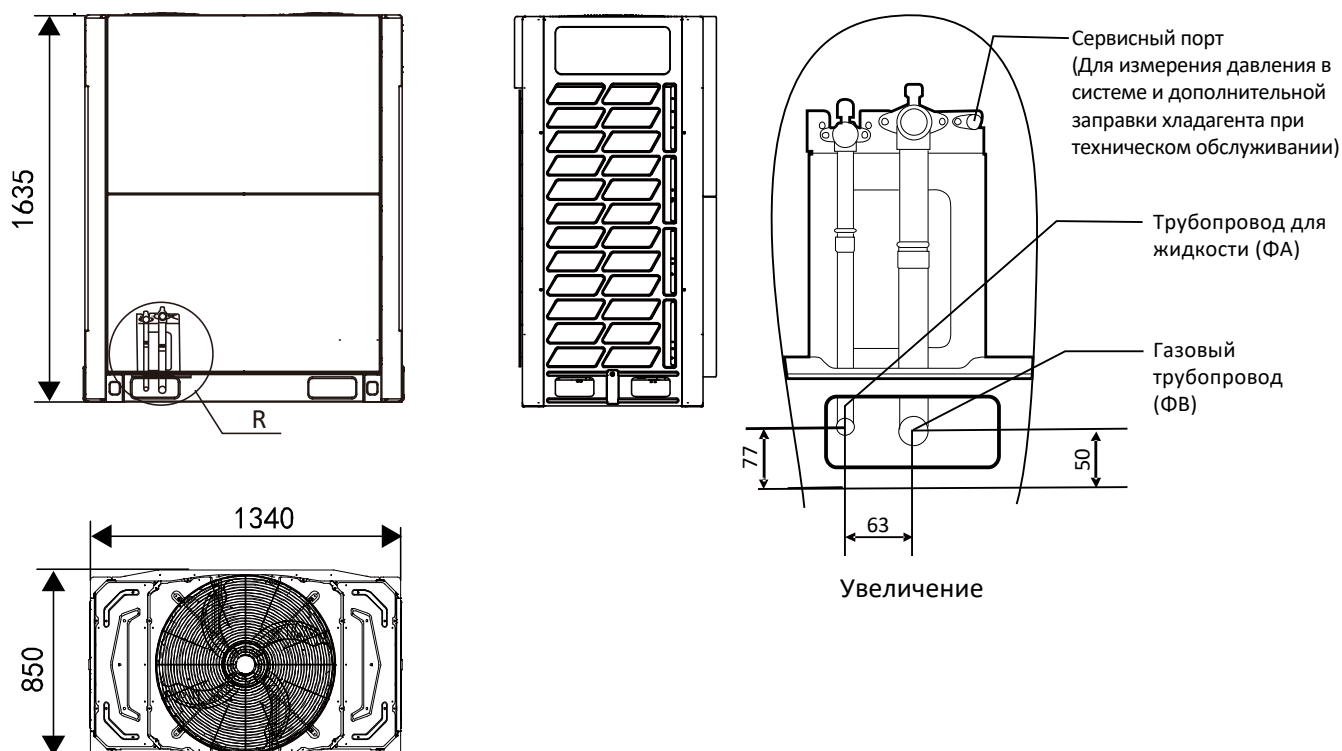
Рисунок 2-2.3: Габаритные размеры блоков производительностью 20/22 л.с. (Единица измерения: мм)



Таблица 2-2.3: Диаметр соединительного трубопровода для блоков производительностью 20/22 л.с. (Единица измерения: мм)

Типоразмер	20 л.с.	22 л.с.
A	Φ19,1	Φ19,1
B	Φ31,8	Φ31,8

24/26/28/30/32 л.с.

Рисунок 2-2.4: Габаритные размеры блоков производительностью 24/26/28/30/32 л.с. (Единица измерения: мм)

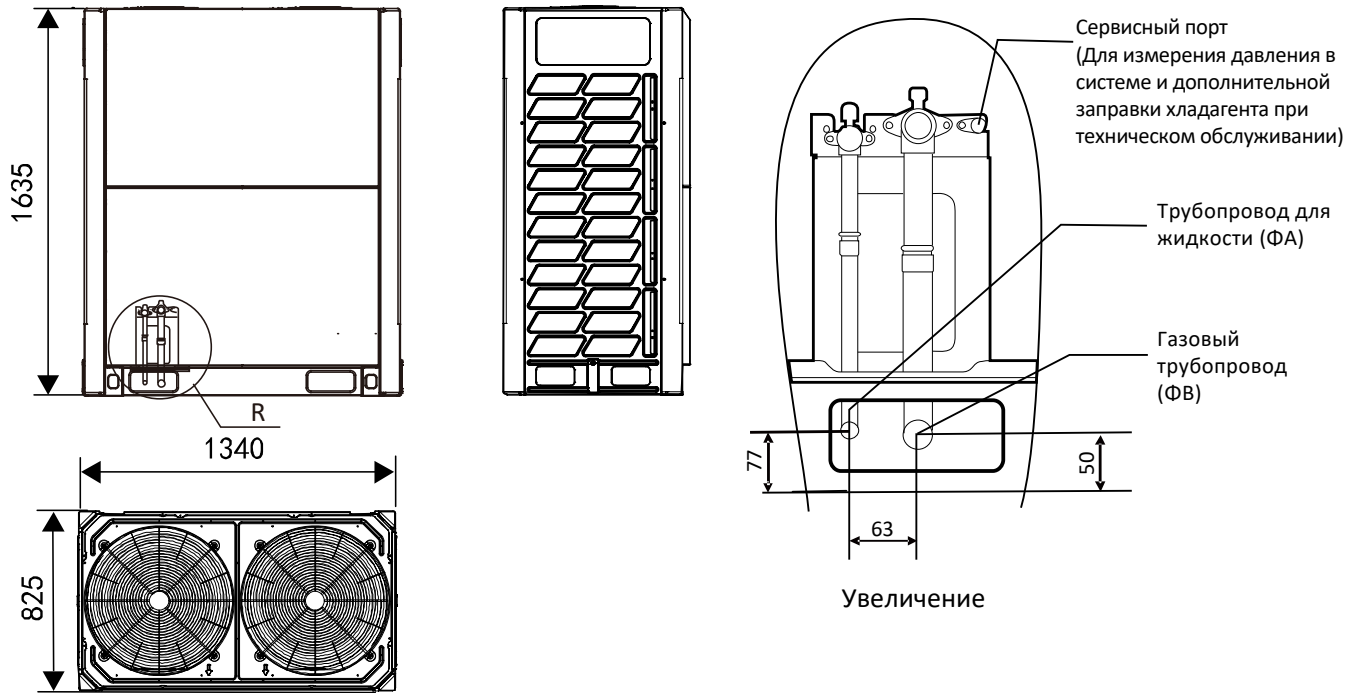

Таблица 2-2.4: Диаметр соединительного трубопровода для блоков производительностью 24/26/28/30/32 л.с. (Единица измерения: мм)

Size	24 л.с.	26 л.с.	28 л.с.	30 л.с.	32 л.с.
A	Φ19,1	Φ22,2	Φ22,2	Φ22,2	Φ22,2
B	Φ31,8	Φ31,8	Φ31,8	Φ38,1	Φ38,1

3. Пространство для монтажа

Для монтажа одиночного блока

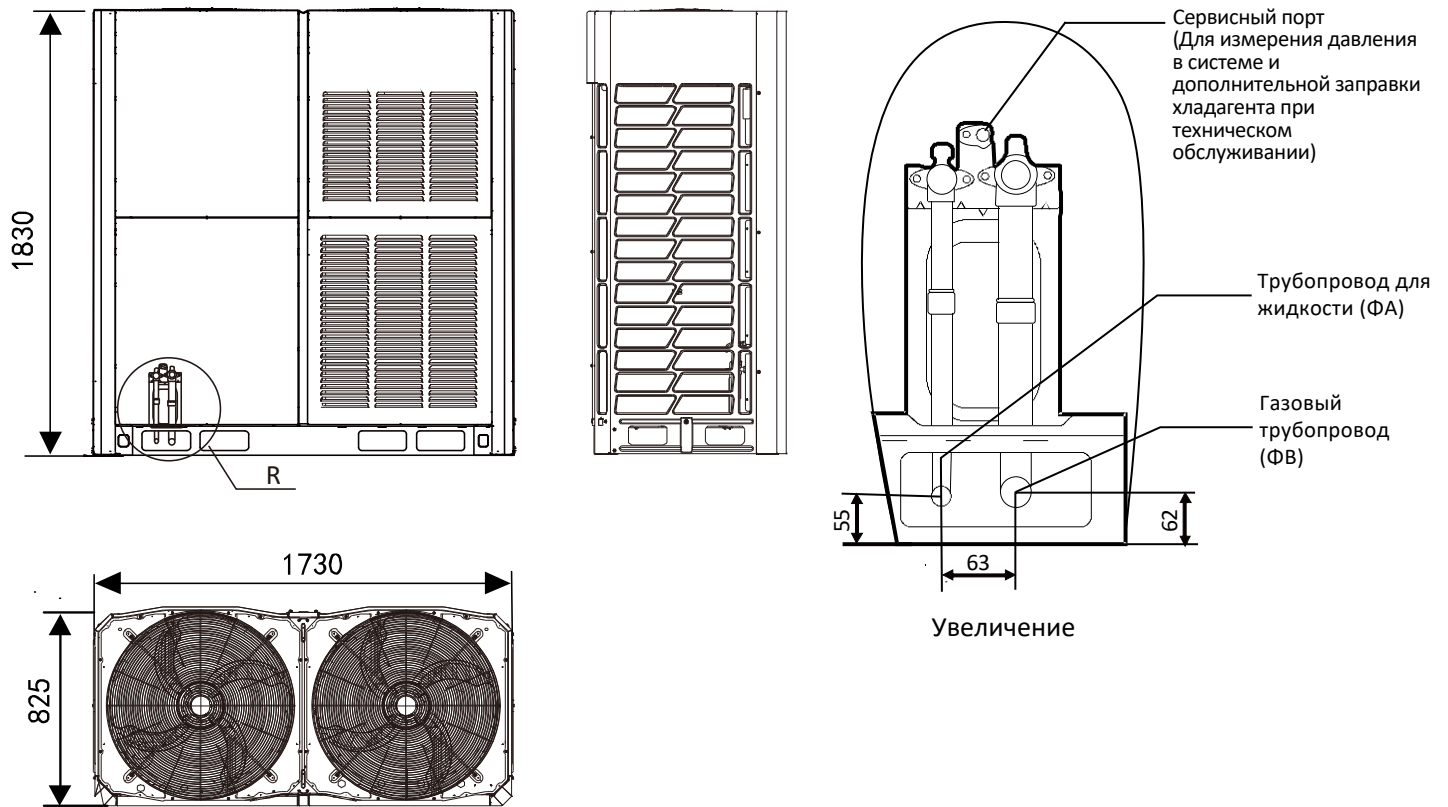
Рисунок 2-3.1: Монтаж одиночного блока
(Единица измерения: мм)

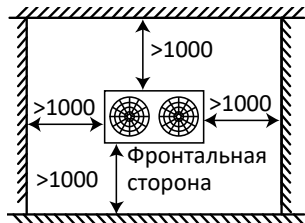

Для монтажа блоков в один ряд

Рисунок 2-3.2: Монтаж блоков в один ряд
(Единица измерения: мм)

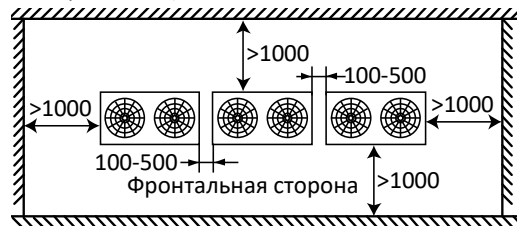

Для монтажа блоков в несколько рядов

Рисунок 2-3.3: Монтаж блоков в несколько рядов (Единица измерения: мм)

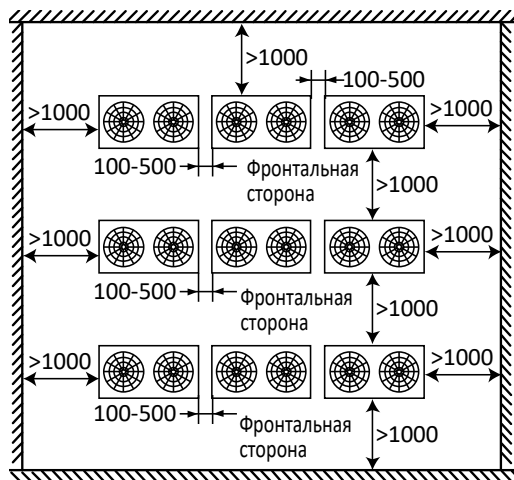

Когда наружный блок располагается ниже окружающих его объектов, во избежание пересечения нагретых потоков воздуха от наружных блоков, которые могут неблагоприятно влиять на эффективность теплообменного процесса, пожалуйста, установите перегородку между наружными блоками для отвода тепла. Высота воздухонаправляющей перегородки $H-h$ показана на Рисунке 2-3.4.

Рисунок 2-3.4: Расстояния при расположении наружного блока ниже окружающих его объектов

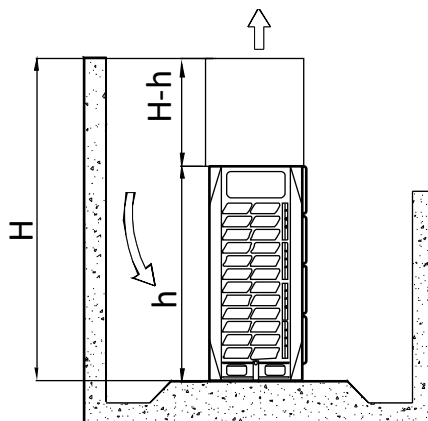

4. Схема холодильного контура

18 л.с.

Рисунок 2-4.2: Схема холодильного контура блоков производительностью 18 л.с.

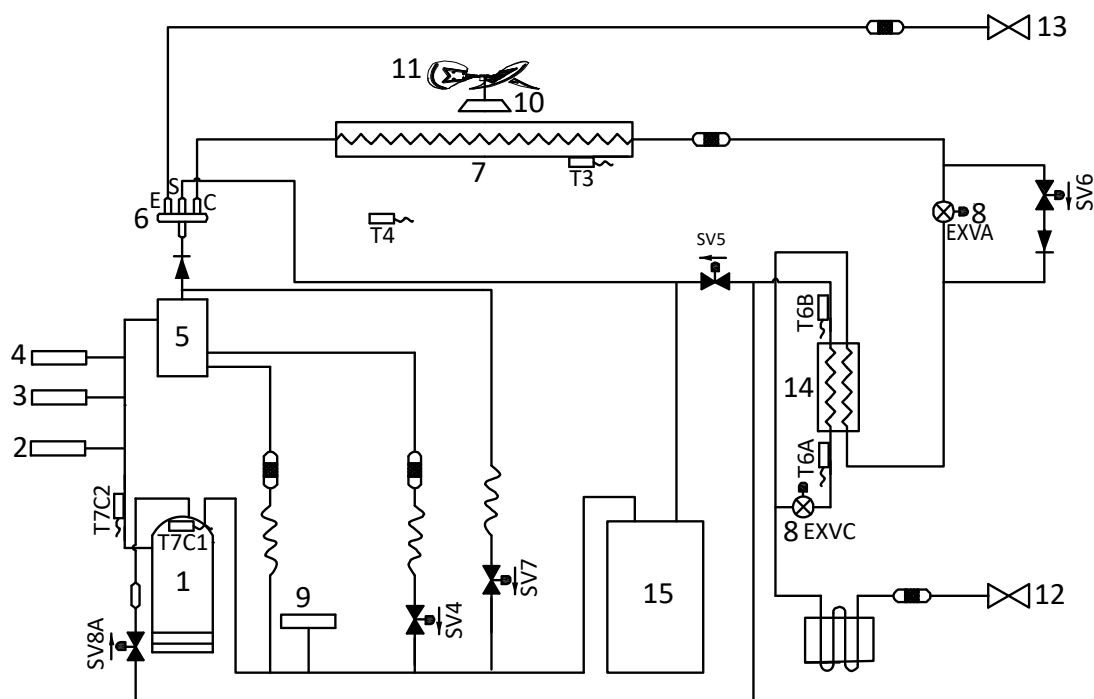

20/22/24 л.с.

Рисунок 2-4.3: Схема холодильного контура блоков производительностью 20/22/24 л.с.

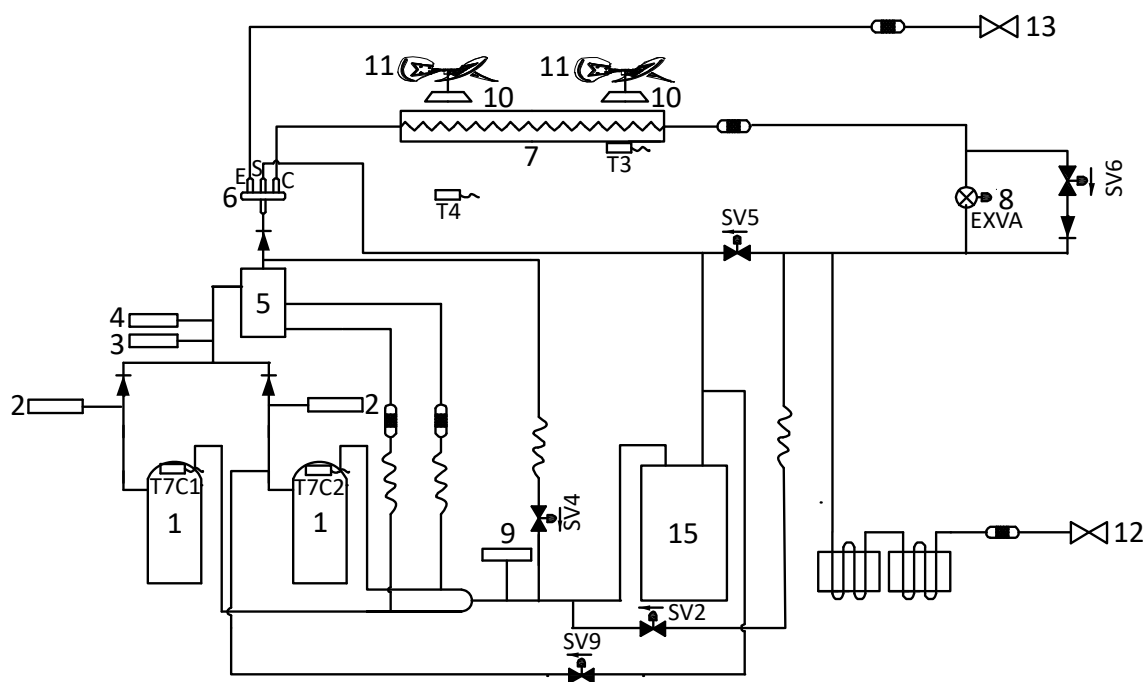

26/28 л.с.

Рисунок 2-4.4: Схема холодильного контура блоков производительностью 26/28 л.с.

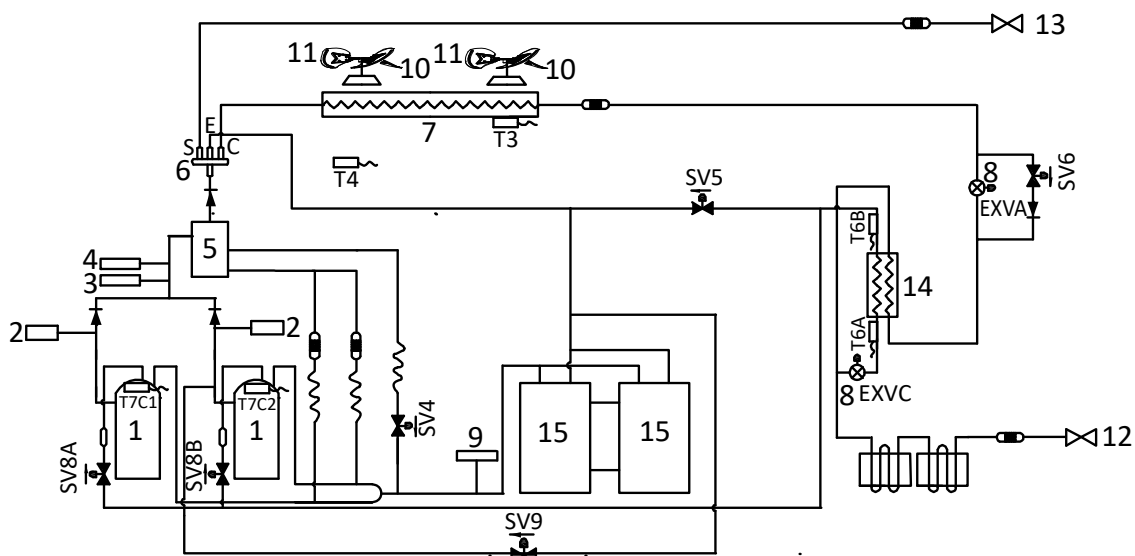

30/32 л.с.

Рисунок 2-4.5: Схема холодильного контура блоков производительностью 30/32 л.с.

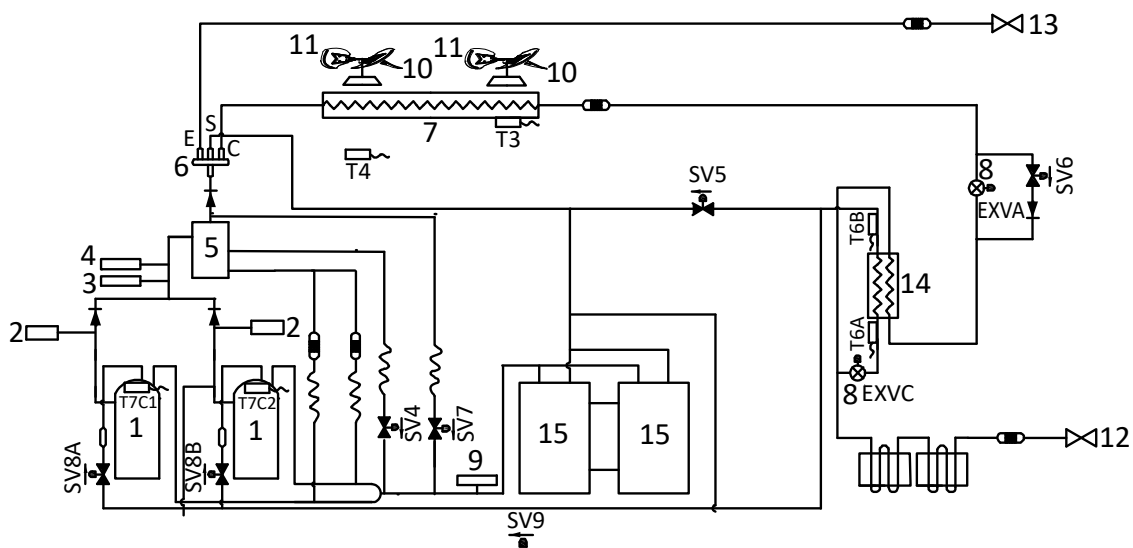

Обозначение			
№.	Наименование части	№.	Наименование части
1	Компрессор	15	Бак-накопитель жидкости
2	Реле температуры нагнетания	T3	Датчик температуры теплообменника
3	Реле высокого давления	T4	Датчик температуры наружного воздуха
4	Датчик высокого давления	T6A	Датчик температуры на входе в пластинчатый теплообменник
5	Отделитель масла	T6B	Датчик температуры на выходе из пластинчатого теплообменника
6	Четырехходовой клапан	T7C1	Датчик температуры нагнетания компрессора А
7	Теплообменник	T7C2	Датчик температуры нагнетания компрессора В
8	Электронный расширительный вентиль (ЭРВ)	SV4	Вентиль возврата масла
9	Реле низкого давления	SV5	Вентиль для быстрого процесса оттайки
10	Двигатель вентилятора	SV6	Вентиль для байпаса
11	Вентилятор	SV7	Вентиль для байпаса
12	Запорный вентиль(сторона жидкости)	SV8A	Вентиль подачи хладагента в компрессор А
13	Запорный вентиль(сторона газа)	SV8B	Вентиль подачи хладагента в компрессор В
14	Пластинчатый теплообменник	SV9	Вентиль выравнивания давления

1. Отделитель масла:

Предназначен для отделения масла от газообразного хладагента, который выкачивается из компрессора. Эффективность отделения достигает 99%, что обеспечивает быстрый возврат масла в компрессор.

2. Бак-накопитель жидкости:

Предназначен для хранения жидкого хладагента и масла и защиты компрессора от гидравлического удара.

3. Электронный расширительный вентиль (ЭРВ):

Предназначен для регулировки расхода хладагента и снижения давления в контуре.

4. Четырехходовой клапан:

Предназначен для изменения направления потока хладагента. Закрывается в режиме охлаждения и открывается в режиме обогрева. Когда клапан закрыт, теплообменник работает как конденсатор. Когда клапан открыт, теплообменник работает как испаритель.

5. Соленоидный вентиль SV4:

Предназначен для возврата масла в компрессор. Открывается через 200 секунд после начала работы компрессора и закрывается через 600 секунд с последующим открытием на 3 минуты через каждые 20 минут.

6. Соленоидный вентиль SV5:

Предназначен для быстрого процесса оттайки. В режиме оттайки открытие вентиля сокращает цикл потока хладагента, тем самым способствуя ускорению процесса оттайки. В режиме охлаждения вентиль всегда закрыт.

7. Соленоидный вентиль SV6:

Предназначен для байпаса. Открывается, когда температура нагнетания чрезмерно высокая в режиме охлаждения, и закрывается, когда блок находится в режиме ожидания или режиме обогрева.

8. Соленоидный вентиль SV7:

Предназначен для возврата хладагента в компрессор. Открывается, когда температура в помещении близка к установленной температуре, во избежание частых пусков компрессора.

9. Соленоидный вентиль SV8A / SV8B:

Предназначен для подачи хладагента из пластинчатого теплообменника в компрессор. Вентиль SV8A открывается при запуске компрессора А и закрывается – при его выключении. Вентиль SV8B открывается с отсрочкой при запуске компрессора В и закрывается – при его выключении.

10. Соленоидный вентиль SV9:

Выравнивает давление компрессора В. Открывается до запуска компрессора В и закрывается через 15 секунд после начала его работы. Открывается через 10 секунд после выключения компрессора В и остаётся открытым в течение 60 секунд.

11. Реле давления:

Предназначено для защиты от повышенного либо пониженного давления в контуре. Когда давление в системе чрезмерно высокое или чрезмерно низкое, реле давления размыкается. Как только реле давления размыкается, компрессор отключается и перезапускается через десять минут.

5. Электрическая схема

18/20/22/24/26/28 л.с.

Рисунок 2-5.1: Электрическая схема для блоков производительностью 18/20/22/24/26/28 л.с.

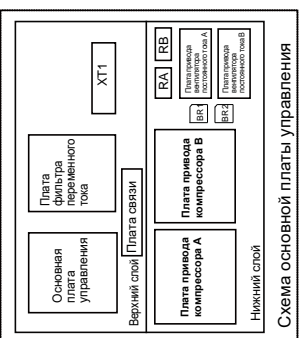
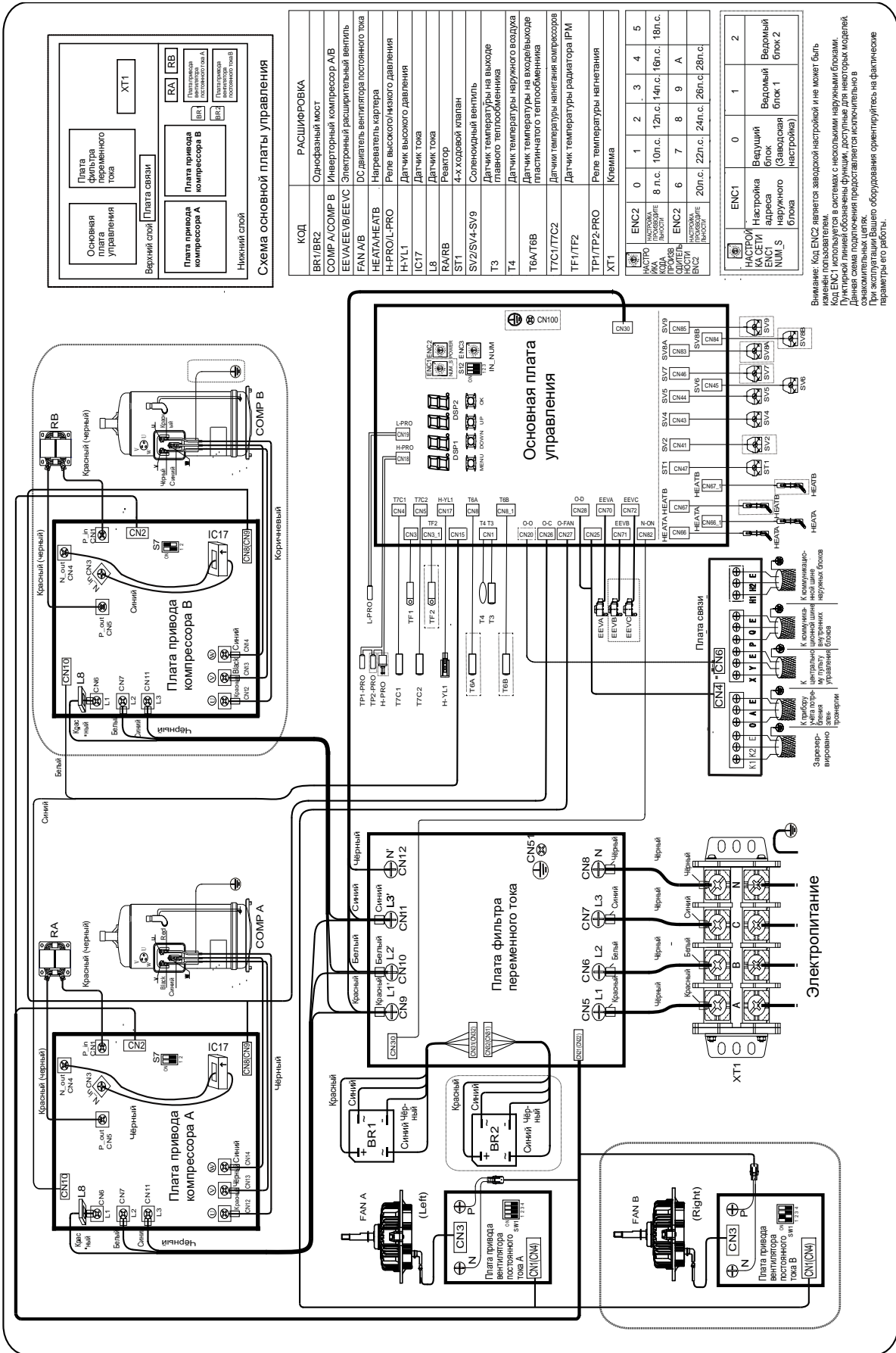

КОД	РАСШИФРОВКА
BR1/BR2	Однофазный мост
COMP.A/COMP.B	Инверторный компрессор А/В
EEVA/EEVB/EEVC	Электронный расширительный вентиль
FAN.A/B	DC двигатель вентилятора постоянного тока
HEAT.A/HEAT.B	Нагреватель картера
H-PRO/L-PRO	Реле высокого/низкого давления
H-YL1	Датчик высокого давления
IC17	Датчик тока
LB	Датчик тока
RA/RB	Реактор
ST1	4-х ходовой клапан
SV2/SV4-SV9	Сolenoidный вентиль
T3	Датчик температуры масла в выводе главного теплообменника
T4	Датчик температуры наружного воздуха
T6A/T6B	Датчик температуры на входе/выходе пластинчатого теплообменника
TC1/TC2	Датчик температуры нагнетания компрессоров
TF1/TF2	Датчик температуры радиатора IPM
TR1/TR2-PRO	Реле температуры нагнетания
XT1	Клемма

НАЗНАЧЕНИЕ	КОДА	ПРОЦЕССОР	МОДУЛЬ	ПРИСОЕДИНЕНИЕ		
ENC2	0	1	2	3	4	5
ENC2	8 л.с.	10 л.с.	12 л.с.	14 л.с.	16 л.с.	18 л.с.
ENC2	6	7	8	9	A	
ENC2	20 л.с.	22 л.с.	24 л.с.	26 л.с.	28 л.с.	

ENC1	0	1	2
НАСТРОЙКА НАСТРОЙКА	Ведущий блок	Ведомый блок	Ведомый блок 2
АДРЕС АДРЕС	0	1	2
NUM.S NUM.S	0	1	2

Внимание: Код ENC2 является заводской настройкой и не может быть изменен пользователем в системах с несколькими наружными блоками. Код ENC1 является заводской настройкой и не может быть изменен. Пунктирной линией обозначены функции, доступные для некоторых моделей. Данная схема подключения предоставляется исключительно в ознакомительных целях. При эксплуатации Вашего оборудования ориентируйтесь на фактические параметры его работы.

30/32 л.с.

Рисунок 2-5.2: Электрическая схема для блоков производительностью 30/32 л.с.

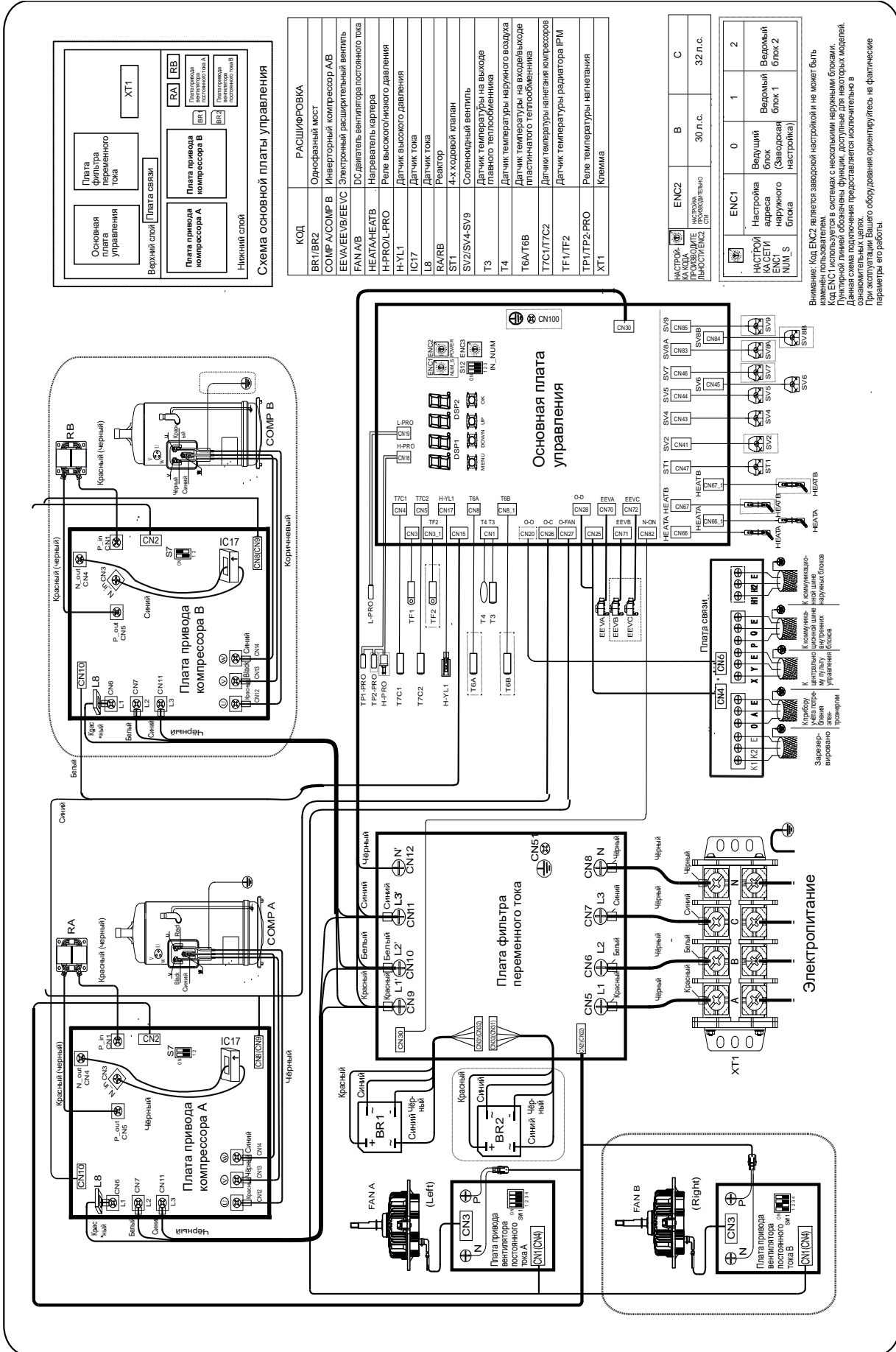

6. Электрические характеристики

Таблица 2-б.1: Электрические характеристики наружных блоков

Производительность	Модель	Электропитание ¹							Компрессор		OFM	
		Гц	Вольт	Мин.	Макс.	MCA ²	TOCA ³	MFA ⁴	MSC ⁵	RLA ⁶	kW	FLA
				Вольт	Вольт							
18 л.с.	DM-FDC540WMC/SF	50/60	380~415	342	440	34,8	41,2	40	/	26,2	0,92	8,2
20 л.с.	DM-FDC600WMC/SF	50/60	380~415	342	440	45,9	60,1	50	/	18+17	0,56×2	10,9
22 л.с.	DM-FDC660WMC/SF	50/60	380~415	342	440	47,9	60,1	63	/	19+18	0,56×2	10,9
24 л.с.	DM-FDC720WMC/SF	50/60	380~415	342	440	54,5	62,3	63	/	20,8+20,6	0,92×2	13,1
26 л.с.	DM-FDC790WMC/SF	50/60	380~415	342	440	52,9	62,3	63	/	20+19,8	0,92×2	13,1
28 л.с.	DM-FDC850WMC/SF	50/60	380~415	342	440	58,7	64,1	63	/	22+21,8	0,92×2	14,9
30 л.с.	DM-FDC920WMC/SF	50/60	380~415	342	440	64,9	72,5	80	/	20+30	0,92×2	14,9
32 л.с.	DM-FDC970WMC/SF	50/60	380~415	342	440	66,9	72,5	80	/	22+30	0,92×2	14,9

Обозначения:

MCA: Минимальный потребляемый ток (А)

TOCA: Общий ток перегрузки (А)

MFA: Максимальный номинал предохранителя (А)

MSC: Максимальный пусковой ток (А)

RLA: Номинальный потребляемый ток (А)

OFM: Двигатель вентилятора наружного блока.

FLA: Полная нагрузка (А)

KW: Расчетная мощность на выходе двигателя (кВт)

Примечание:

1. Диапазон напряжения соответствует требованиям электрического контура, где напряжение электропитания клеммблока не выходит за пределы допустимого диапазона. Максимально допустимые перепады напряжения между фазами составляют 2%.
2. Выбор сечения провода кабеля электропитания зависит от большего значения MCA.
3. TOCA означает общее значение превышение тока.
4. MFA предназначен для подбора устройства защитного отключения и защитный автомата.
5. MSC означает максимальный ток во время запуска компрессора.
6. RLA основан на следующих условиях: температура в помещении +27 °C DB/+19 °C WB, температура наружного воздуха +35° C DB.

7. Функциональные компоненты и устройства защиты

Таблица 2-7.2: Функциональные компоненты и устройства защиты для блоков производительностью 18/20/22/24 л.с.

Компонент		18 л.с.	20 л.с.	22 л.с.	24 л.с.
Компрессор	Реле температуры нагнетания	Выкл.: +115 (±5) °C / Вкл.: +75 (±15) °C			
	Датчики температуры нагнетания на выходе из компрессора	+90 °C = 5 кОм ± 3%			
	Нагреватель картера	30 Вт × 2	30 Вт × 4		
Инверторный модуль	Датчик температуры инверторного модуля	+90°C = 5 кОм ± 5%			
Двигатель вентилятора	Предохранительный термостат	On	+115 °C		
		Выкл.	-		
Система	Реле высокого давления	Выкл.: 4,4 (±0,1) МПа / Вкл.: 3,2 (±0,1) МПа			
	Реле низкого давления	Выкл.: 0,05 (±0,05) МПа / Вкл.: 0,15 (±0,05) МПа			
	Датчик высокого давления	Выходное напряжение (В)=1,1603×P+ 0,5(где P – давление конденсации в МПа)			
	Датчик температуры теплообменника	+25 °C = 10 кОм			
	Датчик температуры наружного воздуха	+25 °C = 10 кОм			

Таблица 2-7.3: Функциональные компоненты и устройства защиты для блоков производительностью 26/28/30/32 л.с.

Компонент		26 л.с.	28 л.с.	30 л.с.	32 л.с.
Компрессор	Реле температуры нагнетания	Выкл.: +115 (±5) °C / Вкл.: +75 (±15) °C			
	Датчики температуры нагнетания на выходе из компрессора	+90 °C = 5 кОм ± 3%			
	Нагреватель картера	30 Вт × 4			
Инверторный модуль	Датчик температуры инверторного модуля	+90°C = 5 кОм ± 5%			
Двигатель вентилятора	Предохранительный термостат	On	+115 °C		
		Off	-		
Система	Реле высокого давления	Off: 4.4 (±0.1) МПа / On: 3.2 (±0.1) МПа			
	Реле низкого давления	Off: 0.05 (±0.05) МПа / On: 0.15 (±0.05) МПа			
	Датчик высокого давления	Выходное напряжение (В)=1,1603×P+ 0,5(где P – давление конденсации в МПа)			
	Датчик температуры теплообменника	+25 °C = 10 кОм			
	Датчик температуры наружного воздуха	+25 °C = 10 кОм			

8. Таблицы производительности

8.1 Таблицы холодопроизводительности

Таблица 2-8.1: Таблица холодопроизводительности для блоков производительностью 18 л.с.

CR	Температура наружного воздуха (°C DB)	Температура в помещении (°C DB/WD)													
		20.8/14		23.3/16		25.8/18		27/19		28.2/20		30.7/22		32/24	
		ТС	PI	ТС	PI	ТС	PI	ТС	PI	ТС	PI	ТС	PI	ТС	PI
		кВт	кВт	кВт	кВт	кВт	кВт	кВт	кВт	кВт	кВт	кВт	кВт	кВт	кВт
130%	-5	45.3	6.08	55.1	6.81	62.1	7.35	63.9	7.97	68.3	8.51	70.2	9.25	70.7	9.31
	-2	45.3	6.08	55.1	6.96	62.1	7.35	64.4	8.02	68.3	8.51	70.2	9.37	70.7	9.41
	0	45.3	6.18	55.1	7.09	62.1	7.64	64.4	8.48	68.3	9.01	70.2	9.49	70.7	9.53
	2	45.3	6.29	55.1	7.10	62.1	7.92	64.4	8.97	68.3	9.11	70.2	9.56	70.7	9.67
	4	45.3	6.43	55.1	7.25	62.1	8.21	64.4	9.01	68.3	9.23	70.2	9.55	70.7	9.86
	6	45.3	6.56	55.1	7.41	62.1	8.54	64.4	9.09	67.2	9.51	68.2	9.55	70.7	9.93
	8	45.3	6.72	55.1	7.59	62.1	9.00	64.4	9.55	66.5	9.83	67.4	9.60	70.0	10.03
	10	45.3	6.85	55.1	7.77	62.1	9.35	64.4	9.88	65.8	9.89	67.2	9.89	69.1	10.32
	12	45.3	6.97	55.1	7.93	62.1	9.55	63.7	10.00	64.9	10.15	66.7	10.07	68.4	10.38
	14	45.3	7.12	55.1	8.09	61.7	9.60	63.2	10.05	64.1	10.25	66.2	10.24	67.5	10.62
	16	45.3	7.24	55.1	8.27	61.0	9.86	62.1	10.25	63.3	10.46	65.7	10.48	66.9	10.78
	18	45.3	7.38	55.1	8.45	60.1	10.01	61.1	10.38	62.5	10.74	65.3	10.84	66.3	10.94
	20	45.3	7.54	55.1	9.03	59.5	10.54	60.2	10.90	61.7	11.26	64.8	11.36	65.6	11.48
	21	45.3	7.74	55.1	9.37	59.2	10.80	60.4	11.16	60.9	11.52	64.3	11.64	65.0	11.74
	23	45.3	8.30	55.1	10.10	58.1	11.32	59.0	11.68	60.1	12.04	63.8	12.16	64.4	12.29
	25	45.3	8.86	55.1	10.86	57.2	11.84	58.2	12.20	59.2	12.59	63.4	12.71	63.8	12.83
	27	45.3	9.46	55.1	11.66	56.4	12.36	57.3	12.99	58.4	13.11	62.9	13.25	63.1	13.39
	29	45.3	10.10	55.1	12.50	55.5	12.88	56.5	13.69	57.6	13.65	62.4	13.79	62.5	13.93
	31	45.3	10.78	53.2	13.26	54.7	13.42	55.8	14.36	56.8	14.17	62.0	14.33	61.9	14.49
	33	45.3	11.48	52.3	13.78	53.9	13.94	54.8	15.15	56.0	14.71	61.5	14.87	61.3	15.03
35	45.3	12.25	51.4	14.30	53.1	14.48	53.9	15.48	55.2	15.25	61.0	15.43	60.6	15.59	
37	45.3	13.03	50.6	14.95	52.3	15.03	53.3	15.41	54.4	15.81	60.5	15.99	60.0	16.17	
39	45.3	13.87	49.7	15.54	51.4	15.61	52.4	15.95	53.9	16.35	60.1	16.53	59.4	16.73	
41	45.3	14.60	49.2	16.13	50.8	16.20	51.6	16.49	52.5	16.81	54.1	16.98	58.7	17.19	
43	45.3	15.17	48.8	16.73	50.5	17.24	50.8	17.49	51.9	17.67	53.1	17.82	58.1	17.99	
45	45.3	15.75	48.5	17.47	50.0	17.98	49.9	18.33	51.2	18.51	51.7	18.62	57.5	19.02	
48	45.3	17.84	48.2	18.30	49.5	18.75	49.1	19.21	50.4	19.66	50.2	20.12	56.9	20.57	
50	45.3	19.94	46.7	20.39	48.4	20.85	48.2	21.30	49.5	21.76	47.2	22.21	56.2	22.67	
52	45.3	22.03	46.0	22.49	47.7	22.94	47.4	23.40	48.7	23.85	44.9	24.31	55.6	24.76	
54	45.3	24.12	45.3	24.58	47.1	25.04	46.6	25.49	47.9	25.95	42.7	26.40	55.0	26.86	
120%	-5	42.3	5.86	49.1	6.35	57.2	7.35	62.2	8.26	65.1	8.80	66.6	9.55	68.0	9.81
	-2	42.3	5.92	49.1	6.42	57.2	7.43	62.2	8.31	65.1	8.91	66.6	9.63	68.0	9.85
	0	42.3	5.98	49.1	6.47	57.2	7.53	62.2	8.33	65.1	8.99	66.6	9.69	68.0	9.87
	2	42.3	5.99	49.1	6.55	57.2	7.59	62.2	8.42	65.1	9.03	66.6	9.77	68.0	9.89
	4	42.3	6.05	49.1	6.64	57.2	7.71	62.2	8.50	65.1	9.16	66.6	9.79	68.0	9.92
	6	42.3	6.12	49.1	6.70	57.2	7.81	62.2	8.61	65.1	9.27	66.6	9.87	68.0	9.95
	8	42.3	6.17	49.1	6.77	57.2	7.93	62.2	8.73	65.1	9.37	66.6	9.90	68.0	10.00
	10	42.3	6.25	49.1	6.87	57.2	8.01	62.2	8.91	65.1	9.38	66.6	9.93	68.0	10.04
	12	42.3	6.37	49.1	7.01	57.2	8.19	62.2	9.09	64.2	9.42	65.7	9.88	67.1	10.11
	14	42.3	6.49	49.1	7.17	57.2	8.37	62.2	9.29	63.3	9.48	64.9	10.03	66.4	10.24
	16	42.3	6.61	49.1	7.33	57.2	8.55	62.1	9.42	62.6	9.63	64.0	10.21	65.5	10.40
	18	42.3	6.73	49.1	7.49	57.2	8.88	60.8	9.71	61.7	9.90	63.1	10.45	64.8	10.55
	20	42.3	6.87	49.1	7.81	57.2	9.64	60.2	10.23	60.9	10.42	62.4	10.97	63.9	11.07
	21	42.3	6.93	49.1	8.11	57.2	10.02	59.1	10.86	60.4	10.68	62.0	11.23	63.5	11.35
	23	42.3	7.41	49.1	8.75	57.2	10.80	57.9	11.72	59.7	11.20	61.1	11.77	62.6	11.87
	25	42.3	7.91	49.1	9.42	56.2	11.32	57.2	12.23	58.8	11.72	60.4	12.29	61.8	12.41
	27	42.3	8.45	49.1	10.12	55.5	11.82	56.3	13.03	58.0	12.26	59.5	12.83	60.9	12.95
	29	42.3	9.01	49.1	10.86	54.6	12.34	55.3	13.58	57.1	12.78	58.6	13.37	60.2	13.49
	31	42.3	9.61	49.1	11.64	53.7	12.88	54.6	14.25	56.4	13.32	57.8	13.91	59.3	14.05
	33	42.3	10.23	49.1	12.46	53.0	13.40	53.7	14.85	55.5	13.84	56.9	14.45	58.4	14.59
35	42.3	10.89	49.1	13.34	52.1	13.92	52.8	15.05	54.7	14.38	56.2	14.99	57.7	15.15	
37	42.3	11.59	49.1	14.26	51.3	14.46	52.1	15.14	53.3	15.23	55.3	15.53	56.8	15.71	
39	42.3	12.33	49.0	15.10	50.4	14.98	51.2	15.23	52.4	15.46	54.6	16.09	56.0	16.25	
41	42.3	13.01	48.6	15.21	50.0	15.51	50.8	15.95	51.5	16.00	53.1	16.63	54.4	16.81	
43	42.3	13.58	48.3	15.33	49.6	15.94	50.4	16.30	51.1	16.54	52.2	17.17	53.6	17.36	
45	42.3	14.15	48.0	15.48	49.2	16.26	49.8	16.87	50.6	17.08	51.1	17.72	53.2	17.91	
48	42.3	16.23	47.7	16.68	48.7	17.13	49.4	17.59	50.2	18.04	50.2	18.49	52.6	18.94	
50	42.3	18.31	47.5	18.76	48.2	19.21	48.8	19.66	49.4	20.12	49.1	20.57	51.4	21.02	
52	42.3	20.39	47.2	20.84	47.7	21.29	48.3	21.74	48.8	22.19	48.0	22.64	50.6	23.10	
54	42.3	22.46	46.9	22.91	47.2	23.37	47.8	23.82	48.2	24.27	47.0	24.72	49.7	25.17	

Обозначения:

CR: Индекс установленной мощности; ТС: Полная производительность (кВт); PI: Потребляемая мощность (компрессор + двигатель вентилятора наружного блока) (кВт)

Примечание: 1. В серых ячейках указаны расчётные значения.

Продолжение таблицы на следующей странице...

Таблица 2-8.1: Таблица холодопроизводительности для блоков производительностью 18 л.с. (продолжение)

CR	Температура наружного воздуха (°C DB)	Температура в помещении (°C DB/WD)													
		20.8/14		23.3/16		25.8/18		27/19		28.2/20		30.7/22		32/24	
		ТС	PI	ТС	PI	ТС	PI	ТС	PI	ТС	PI	ТС	PI	ТС	PI
	кВт	кВт	кВт	кВт	кВт	кВт	кВт	кВт	кВт	кВт	кВт	кВт	кВт	кВт	кВт
110%	-5	39.1	5.12	45.2	5.78	54.6	6.86	56.4	7.72	60.8	8.49	65.3	8.83	66.8	9.41
	-2	39.1	5.22	45.2	5.86	54.6	6.93	56.4	7.80	60.8	8.56	65.3	8.92	66.8	9.46
	0	39.1	5.28	45.2	5.90	54.6	6.99	56.4	7.86	60.8	8.66	65.3	9.01	66.8	9.58
	2	39.1	5.39	45.2	5.96	54.6	7.11	56.4	7.95	60.8	8.76	65.3	9.15	66.8	9.70
	4	39.1	5.50	45.2	6.04	54.6	7.18	56.4	8.05	60.8	8.89	65.3	9.28	66.8	9.79
	6	39.1	5.55	45.2	6.11	54.6	7.26	56.4	8.19	60.8	9.00	65.3	9.38	66.8	9.94
	8	39.1	5.60	45.2	6.22	54.6	7.35	56.4	8.28	60.8	9.10	65.3	9.44	66.8	10.04
	10	39.1	5.67	45.2	6.31	54.6	7.47	56.4	8.43	60.8	9.26	65.3	9.51	66.8	10.13
	12	39.1	5.79	45.2	6.45	54.6	7.63	56.4	8.61	60.8	9.44	64.6	9.66	65.9	10.26
	14	39.1	5.89	45.2	6.57	54.6	7.79	56.4	8.77	60.8	9.62	63.7	9.74	65.1	10.33
	16	39.1	5.99	45.2	6.71	54.6	7.95	56.4	8.95	60.8	9.82	62.9	9.86	64.2	10.45
	18	39.1	6.11	45.2	6.85	54.6	8.13	56.4	9.21	60.8	10.30	62.0	10.38	63.5	10.78
	20	39.1	6.23	45.2	7.01	54.6	8.65	56.4	9.93	59.9	10.82	61.3	10.90	62.6	11.30
	21	39.1	6.29	45.2	7.23	54.6	8.99	56.4	10.71	59.5	11.08	60.8	11.16	62.2	11.56
	23	39.1	6.59	45.2	7.80	54.6	9.69	56.4	11.40	58.6	11.58	60.0	11.70	61.3	12.10
	25	39.1	7.03	45.2	8.38	54.6	10.41	56.4	12.16	57.8	12.10	59.1	12.22	60.6	12.62
	27	39.1	7.49	45.2	9.00	54.6	11.19	55.7	12.75	56.9	12.62	58.4	12.74	59.7	13.16
	29	39.1	7.99	45.2	9.64	54.6	12.01	54.7	13.49	56.2	13.16	57.5	13.28	58.9	13.70
	31	39.1	8.51	45.2	10.32	54.6	12.87	53.6	14.23	55.3	13.68	56.8	13.80	58.0	14.24
	33	39.1	9.06	45.2	11.04	54.6	13.61	53.3	14.78	54.6	14.20	55.8	14.35	57.3	14.79
	35	39.1	9.64	45.2	11.80	51.7	14.14	51.9	14.96	53.7	14.75	54.9	14.89	56.4	15.33
	37	39.1	10.55	45.2	12.60	50.4	14.68	51.3	15.04	52.8	15.27	54.2	15.43	55.5	15.87
	39	39.1	11.45	45.2	13.47	49.5	15.20	50.4	15.58	51.8	15.81	53.3	15.97	54.8	16.43
	41	39.1	12.35	45.2	13.58	48.6	15.31	49.9	15.69	51.0	15.92	51.6	16.15	53.1	16.54
43	39.1	13.25	45.2	13.76	47.7	15.42	49.3	15.80	50.1	16.03	51.2	16.58	52.3	16.88	
45	39.1	14.00	45.2	14.25	46.8	15.74	48.4	16.13	49.3	16.36	49.8	16.94	51.2	17.43	
48	39.1	16.07	45.2	16.51	45.9	16.96	47.8	17.41	48.4	17.86	49.3	18.31	50.1	18.76	
50	39.1	18.13	44.1	18.58	45.0	19.03	47.1	19.48	47.6	19.93	48.2	20.38	49.0	20.82	
52	39.1	20.20	43.1	20.64	44.1	21.09	46.4	21.54	46.7	21.99	47.2	22.44	47.8	22.89	
54	39.1	22.26	42.1	22.71	43.2	23.16	45.6	23.61	45.8	24.06	46.2	24.51	46.7	24.95	
100%	-5	35.1	5.26	41.2	5.73	49.3	6.32	50.0	7.42	54.2	7.25	62.3	8.03	64.2	8.85
	-2	35.1	5.34	41.2	5.81	49.3	6.45	50.0	7.48	54.2	7.35	62.3	8.13	64.2	8.91
	0	35.1	5.39	41.2	5.88	49.3	6.56	50.0	7.59	54.2	7.42	62.3	8.28	64.2	9.01
	2	35.1	5.47	41.2	5.95	49.3	6.71	50.0	7.66	54.2	7.51	62.3	8.41	64.2	9.16
	4	35.1	5.53	41.2	6.06	49.3	6.79	50.0	7.77	54.2	7.61	62.3	8.50	64.2	9.26
	6	35.1	5.64	41.2	6.14	49.3	6.91	50.0	7.94	54.2	7.73	62.3	8.63	64.2	9.41
	8	35.1	5.73	41.2	6.27	49.3	7.04	50.0	8.08	54.2	7.86	62.3	8.78	64.2	9.57
	10	35.1	5.85	41.2	6.39	49.3	7.15	50.0	8.21	54.2	8.02	62.3	8.93	64.2	9.71
	12	35.1	5.97	41.2	6.53	49.3	7.42	50.0	8.37	54.2	8.18	62.3	9.11	63.3	9.79
	14	35.1	6.09	41.2	6.67	49.3	7.77	50.0	8.91	54.2	8.33	62.3	9.31	62.6	9.91
	16	35.1	6.20	41.2	6.83	49.3	7.96	50.0	9.13	54.2	8.51	60.5	9.43	61.7	10.03
	18	35.1	6.32	41.2	6.96	49.3	8.26	50.0	9.49	54.2	8.69	59.8	9.77	61.0	10.29
	20	35.1	6.46	41.2	7.20	49.3	8.95	50.0	10.14	54.2	9.35	58.9	10.26	60.1	10.80
	21	35.1	6.52	41.2	7.50	49.3	9.59	50.0	10.75	54.2	9.68	58.5	10.52	59.8	11.06
	23	35.1	6.98	41.2	8.09	49.3	10.31	50.0	11.49	54.2	10.41	57.8	11.03	58.9	11.57
	25	35.1	7.47	41.2	8.73	49.3	11.13	50.0	12.07	54.2	11.19	56.9	11.55	58.1	12.09
	27	35.1	7.99	41.2	9.38	49.3	11.78	50.0	12.79	54.2	12.00	56.0	12.06	57.3	12.62
	29	35.1	8.54	41.2	10.07	49.3	12.67	50.0	13.17	54.0	12.77	55.3	13.04	56.5	13.14
	31	35.1	9.14	41.2	10.81	49.3	13.55	50.0	13.41	53.3	13.29	54.4	13.51	55.6	13.67
	33	35.1	9.75	41.2	11.58	49.3	14.19	50.0	13.79	52.4	13.80	53.7	14.00	54.9	14.21
	35	35.1	10.38	41.2	12.41	49.3	14.48	50.0	14.70	51.5	14.72	52.8	14.87	54.0	15.02
	37	35.1	11.08	41.2	13.28	49.3	14.59	49.4	15.37	51.0	15.59	52.1	15.78	53.1	15.99
	39	35.1	11.79	41.2	14.19	49.3	14.85	48.7	15.97	50.3	16.24	51.2	16.56	52.4	16.69
	41	35.1	12.23	41.2	14.75	49.3	15.07	48.1	16.54	49.6	16.88	49.3	17.04	51.7	17.22
43	35.1	12.67	41.2	15.04	49.3	15.57	47.9	17.32	48.9	17.60	49.6	17.90	49.8	18.04	
45	35.1	13.26	41.2	15.45	49.3	16.55	47.6	18.42	48.2	19.44	49.2	20.42	49.0	20.81	
48	35.1	15.29	41.2	16.47	49.3	17.64	47.1	19.85	47.5	21.02	48.1	22.20	48.3	23.37	
50	35.1	17.32	41.2	18.49	49.3	19.67	46.6	20.85	46.8	22.02	47.3	23.20	47.5	24.37	
52	35.1	19.35	41.2	20.52	49.3	21.70	46.2	22.87	46.1	24.05	46.6	25.23	46.8	26.40	
54	35.1	21.38	41.2	22.55	49.3	23.73	45.8	24.90	45.4	26.08	45.9	27.26	46.1	28.43	

Обозначения:

CR: Индекс установленной мощности;

ТС: Полная производительность (кВт);

PI: Потребляемая мощность (компрессор + двигатель вентилятора наружного блока) (кВт)

Примечание: 1. В серых ячейках указаны расчётные значения.

Продолжение таблицы на следующей странице...

MVS FDC II-S

Таблица 2-8.1: Таблица холодопроизводительности для блоков производительностью 18 л.с. (продолжение)

CR	Температура наружного воздуха (°CDB)	Температура в помещении (°CDB/WD)													
		20.8/14		23.3/16		25.8/18		27/19		28.2/20		30.7/22		32/24	
		ТС	PI	ТС	PI	ТС	PI	ТС	PI	ТС	PI	ТС	PI	ТС	PI
		кВт	кВт	кВт	кВт	кВт	кВт	кВт	кВт	кВт	кВт	кВт	кВт	кВт	кВт
90%	-5	30.5	4.21	36.4	4.59	42.3	5.06	45.2	5.94	48.9	5.80	55.7	6.42	59.8	7.08
	-2	30.5	4.27	36.4	4.65	42.3	5.16	45.2	5.98	48.9	5.88	55.7	6.50	59.8	7.13
	0	30.5	4.32	36.4	4.70	42.3	5.25	45.2	6.07	48.9	5.94	55.7	6.62	59.8	7.21
	2	30.5	4.38	36.4	4.76	42.3	5.36	45.2	6.13	48.9	6.01	55.7	6.73	59.8	7.33
	4	30.5	4.42	36.4	4.85	42.3	5.43	45.2	6.22	48.9	6.09	55.7	6.80	59.8	7.41
	6	30.5	4.52	36.4	4.92	42.3	5.53	45.2	6.35	48.9	6.19	55.7	6.90	59.8	7.53
	8	30.5	4.59	36.4	5.02	42.3	5.63	45.2	6.47	48.9	6.29	55.7	7.02	59.8	7.66
	10	30.5	4.68	36.4	5.11	42.3	5.72	45.2	6.57	48.9	6.42	55.7	7.15	59.8	7.77
	12	30.5	4.77	36.4	5.22	42.3	5.94	45.2	6.70	48.9	6.54	55.7	7.29	59.8	7.83
	14	30.5	4.87	36.4	5.33	42.3	6.21	45.2	7.12	48.9	6.67	55.7	7.45	59.8	7.93
	16	30.5	4.96	36.4	5.46	42.3	6.36	45.2	7.30	48.9	6.81	55.7	7.54	59.8	8.02
	18	30.5	5.06	36.4	5.57	42.3	6.61	45.2	7.59	48.9	6.95	55.7	7.81	59.8	8.23
	20	30.5	5.17	36.4	5.76	42.3	7.16	45.2	8.11	48.9	7.48	55.7	8.21	59.8	8.64
	21	30.5	5.22	36.4	6.00	42.3	7.67	45.2	8.60	48.9	7.75	55.7	8.41	59.8	8.85
	23	30.5	5.58	36.4	6.47	42.3	8.25	45.2	9.20	48.9	8.33	55.7	8.83	59.8	9.26
	25	30.5	5.98	36.4	6.98	42.3	8.90	45.2	9.66	48.9	8.95	55.7	9.24	59.8	9.67
	27	30.5	6.39	36.4	7.50	42.3	9.43	45.2	10.24	48.9	9.60	55.7	9.65	59.8	10.10
	29	30.5	6.83	36.4	8.06	42.3	10.13	45.2	10.54	48.9	10.22	55.7	10.43	59.8	10.51
	31	30.5	7.31	36.4	8.64	42.3	10.84	45.2	10.73	48.9	10.63	55.7	10.81	59.8	10.94
	33	30.5	7.80	36.4	9.26	42.3	11.35	45.2	11.04	48.9	11.04	55.7	11.20	59.8	11.37
	35	30.5	8.31	36.4	9.93	42.3	11.59	45.2	11.76	48.9	11.78	55.7	11.90	59.8	12.01
	37	30.5	8.86	36.4	10.63	42.3	11.67	45.2	12.29	48.9	12.47	55.7	12.63	59.8	12.79
	39	30.5	9.43	36.4	11.36	42.3	11.88	45.2	12.49	48.9	12.99	55.7	13.25	59.8	13.36
	41	30.5	9.79	36.4	11.80	42.3	12.06	45.2	12.72	48.9	13.50	55.7	13.63	59.8	13.77
43	30.5	10.14	36.4	12.03	42.3	12.46	45.2	12.96	48.9	14.08	55.7	14.32	59.8	14.43	
45	30.5	10.61	36.4	12.36	42.3	13.24	45.2	13.19	48.9	14.38	55.7	14.92	59.8	15.24	
48	30.5	12.23	36.4	12.82	42.3	13.41	45.2	14.00	48.9	14.58	55.7	15.17	59.8	15.76	
50	30.5	13.85	36.4	14.44	42.3	15.03	45.2	15.62	48.9	16.21	55.7	16.79	59.8	17.38	
52	30.5	15.48	36.4	16.07	42.3	16.65	45.2	17.24	48.9	17.83	55.7	18.42	59.8	19.01	
54	30.5	17.10	36.4	17.69	42.3	18.28	45.2	18.86	48.9	19.45	55.7	20.04	59.8	20.63	
80%	-5	27.1	3.22	32.3	3.33	37.6	3.87	40.3	3.61	43.8	4.81	49.8	5.53	53.4	6.33
	-2	27.1	3.27	32.3	3.37	37.6	3.92	40.3	3.62	43.8	4.86	49.8	5.58	53.4	6.39
	0	27.1	3.30	32.3	3.41	37.6	3.99	40.3	3.70	43.8	4.93	49.8	5.64	53.4	6.44
	2	27.1	3.35	32.3	3.46	37.6	4.03	40.3	3.86	43.8	5.00	49.8	5.76	53.4	6.53
	4	27.1	3.38	32.3	3.51	37.6	4.10	40.3	3.87	43.8	5.07	49.8	5.85	53.4	6.63
	6	27.1	3.46	32.3	3.58	37.6	4.18	40.3	3.98	43.8	5.16	49.8	5.94	53.4	6.74
	8	27.1	3.51	32.3	3.65	37.6	4.28	40.3	4.13	43.8	5.25	49.8	6.05	53.4	6.80
	10	27.1	3.58	32.3	3.74	37.6	4.36	40.3	4.17	43.8	5.37	49.8	6.13	53.4	6.91
	12	27.1	3.65	32.3	3.81	37.6	4.44	40.3	4.28	43.8	5.47	49.8	6.25	53.4	7.04
	14	27.1	3.73	32.3	3.88	37.6	4.53	40.3	4.37	43.8	5.56	49.8	6.36	53.4	7.17
	16	27.1	3.80	32.3	3.95	37.6	4.63	40.3	4.47	43.8	5.68	49.8	6.49	53.4	7.30
	18	27.1	3.87	32.3	4.04	37.6	4.71	40.3	4.63	43.8	5.79	49.8	6.61	53.4	7.52
	20	27.1	3.96	32.3	4.13	37.6	4.81	40.3	5.04	43.8	6.00	49.8	7.11	53.4	7.88
	21	27.1	3.99	32.3	4.16	37.6	4.90	40.3	5.41	43.8	6.22	49.8	7.37	53.4	8.06
	23	27.1	4.27	32.3	4.33	37.6	5.27	40.3	5.87	43.8	6.67	49.8	7.91	53.4	8.43
	25	27.1	4.57	32.3	4.65	37.6	5.65	40.3	6.31	43.8	7.13	49.8	8.46	53.4	8.80
	27	27.1	4.89	32.3	4.96	37.6	6.05	40.3	6.92	43.8	7.62	49.8	9.06	53.4	9.17
	29	27.1	5.23	32.3	5.30	37.6	6.47	40.3	7.21	43.8	8.15	49.8	9.47	53.4	9.54
	31	27.1	5.59	32.3	5.65	37.6	6.91	40.3	7.71	43.8	8.69	49.8	9.84	53.4	9.92
	33	27.1	5.97	32.3	6.02	37.6	7.39	40.3	8.21	43.8	9.27	49.8	10.22	53.4	10.29
	35	27.1	6.36	32.3	6.42	37.6	7.89	40.3	9.00	43.8	9.88	49.8	10.59	53.4	10.67
	37	27.1	6.78	32.3	6.83	37.6	8.42	40.3	9.41	43.8	10.53	49.8	10.96	53.4	11.04
	39	27.1	7.22	32.3	7.29	37.6	8.97	40.3	9.77	43.8	11.23	49.8	11.34	53.4	11.43
	41	27.1	7.49	32.3	7.62	37.6	9.31	40.3	10.13	43.8	11.28	49.8	11.63	53.4	11.70
43	27.1	7.76	32.3	7.96	37.6	9.65	40.3	10.61	43.8	11.52	49.8	11.78	53.4	11.88	
45	27.1	8.12	32.3	8.37	37.6	10.05	40.3	11.28	43.8	11.84	49.8	11.90	53.4	12.04	
48	27.1	9.36	32.3	10.08	37.6	10.80	40.3	11.52	43.8	12.24	49.8	12.96	53.4	13.68	
50	27.1	10.60	32.3	11.32	37.6	12.04	40.3	12.76	43.8	13.48	49.8	14.20	53.4	14.92	
52	27.1	11.84	32.3	12.56	37.6	13.28	40.3	14.00	43.8	14.72	49.8	15.44	53.4	16.16	
54	27.1	13.09	32.3	13.81	37.6	14.53	40.3	15.25	43.8	15.97	49.8	16.69	53.4	17.41	

Обозначения:

CR: Индекс установленной мощности;
 ТС: Полная производительность (кВт);
 PI: Потребляемая мощность (компрессор + двигатель вентилятора наружного блока) (кВт)

Примечание: 1. В серых ячейках указаны расчётные значения.

Продолжение таблицы на следующей странице...

Таблица 2-8.1: Таблица холодопроизводительности для блоков производительностью 18 л.с. (продолжение)

CR	Температура наружного воздуха (°C DB)	Температура в помещении (°C DB/WD)													
		20.8/14		23.3/16		25.8/18		27/19		28.2/20		30.7/22		32/24	
		ТС	PI	ТС	PI	ТС	PI	ТС	PI	ТС	PI	ТС	PI	ТС	PI
	кВт	кВт	кВт	кВт	кВт	кВт	кВт	кВт	кВт	кВт	кВт	кВт	кВт	кВт	кВт
70%	-5	23.8	2.61	28.5	2.70	33.0	3.14	35.3	3.62	38.3	3.90	43.6	4.48	46.8	5.13
	-2	23.8	2.65	28.5	2.73	33.0	3.18	35.3	3.64	38.3	3.94	43.6	4.52	46.8	5.18
	0	23.8	2.68	28.5	2.77	33.0	3.23	35.3	3.66	38.3	3.99	43.6	4.58	46.8	5.22
	2	23.8	2.72	28.5	2.80	33.0	3.27	35.3	3.76	38.3	4.06	43.6	4.67	46.8	5.30
	4	23.8	2.74	28.5	2.85	33.0	3.33	35.3	3.82	38.3	4.11	43.6	4.74	46.8	5.38
	6	23.8	2.80	28.5	2.90	33.0	3.39	35.3	3.89	38.3	4.18	43.6	4.82	46.8	5.47
	8	23.8	2.85	28.5	2.96	33.0	3.47	35.3	3.96	38.3	4.25	43.6	4.91	46.8	5.52
	10	23.8	2.90	28.5	3.03	33.0	3.53	35.3	4.03	38.3	4.35	43.6	4.97	46.8	5.60
	12	23.8	2.96	28.5	3.09	33.0	3.60	35.3	4.10	38.3	4.43	43.6	5.06	46.8	5.71
	14	23.8	3.02	28.5	3.15	33.0	3.67	35.3	4.23	38.3	4.51	43.6	5.16	46.8	5.81
	16	23.8	3.08	28.5	3.20	33.0	3.75	35.3	4.25	38.3	4.60	43.6	5.26	46.8	5.92
	18	23.8	3.14	28.5	3.27	33.0	3.82	35.3	4.26	38.3	4.70	43.6	5.36	46.8	6.10
	20	23.8	3.21	28.5	3.35	33.0	3.90	35.3	4.54	38.3	4.87	43.6	5.77	46.8	6.39
	21	23.8	3.24	28.5	3.38	33.0	3.97	35.3	4.86	38.3	5.04	43.6	5.97	46.8	6.54
	23	23.8	3.46	28.5	3.51	33.0	4.27	35.3	5.12	38.3	5.41	43.6	6.41	46.8	6.84
	25	23.8	3.71	28.5	3.77	33.0	4.58	35.3	5.50	38.3	5.78	43.6	6.86	46.8	7.14
	27	23.8	3.96	28.5	4.02	33.0	4.90	35.3	5.90	38.3	6.18	43.6	7.34	46.8	7.43
	29	23.8	4.24	28.5	4.30	33.0	5.25	35.3	6.17	38.3	6.61	43.6	7.68	46.8	7.73
	31	23.8	4.54	28.5	4.58	33.0	5.60	35.3	6.58	38.3	7.04	43.6	7.98	46.8	8.05
	33	23.8	4.84	28.5	4.88	33.0	6.00	35.3	6.98	38.3	7.52	43.6	8.29	46.8	8.34
	35	23.8	5.15	28.5	5.21	33.0	6.40	35.3	7.30	38.3	8.01	43.6	8.59	46.8	8.66
	37	23.8	5.50	28.5	5.54	33.0	6.82	35.3	7.63	38.3	8.54	43.6	8.89	46.8	8.95
	39	23.8	5.85	28.5	5.91	33.0	7.27	35.3	7.93	38.3	9.11	43.6	9.20	46.8	9.27
	41	23.8	6.07	28.5	6.18	33.0	7.55	35.3	8.21	38.3	9.15	43.6	9.43	46.8	9.48
43	23.8	6.29	28.5	6.46	33.0	7.82	35.3	8.60	38.3	9.34	43.6	9.55	46.8	9.63	
45	23.8	6.58	28.5	6.78	33.0	8.15	35.3	9.15	38.3	9.60	43.6	10.38	46.8	10.83	
48	23.8	7.59	28.5	8.32	33.0	9.05	35.3	9.78	38.3	10.51	43.6	11.24	46.8	11.97	
50	23.8	8.60	28.5	9.33	33.0	10.06	35.3	10.79	38.3	11.52	43.6	12.25	46.8	12.97	
52	23.8	9.60	28.5	10.33	33.0	11.06	35.3	11.79	38.3	12.52	43.6	13.25	46.8	13.98	
54	23.8	10.61	28.5	11.34	33.0	12.07	35.3	12.80	38.3	13.53	43.6	14.26	46.8	14.99	
60%	-5	20.3	2.11	24.2	2.29	28.2	2.53	30.2	3.24	32.7	3.53	37.3	3.92	40.0	4.50
	-2	20.3	2.14	24.2	2.32	28.2	2.56	30.2	3.28	32.7	3.59	37.3	3.98	40.0	4.53
	0	20.3	2.16	24.2	2.35	28.2	2.61	30.2	3.32	32.7	3.64	37.3	4.04	40.0	4.59
	2	20.3	2.19	24.2	2.38	28.2	2.64	30.2	3.39	32.7	3.69	37.3	4.12	40.0	4.65
	4	20.3	2.21	24.2	2.42	28.2	2.68	30.2	3.43	32.7	3.77	37.3	4.19	40.0	4.71
	6	20.3	2.26	24.2	2.46	28.2	2.74	30.2	3.51	32.7	3.84	37.3	4.27	40.0	4.82
	8	20.3	2.29	24.2	2.51	28.2	2.79	30.2	3.57	32.7	3.92	37.3	4.35	40.0	4.90
	10	20.3	2.34	24.2	2.56	28.2	2.85	30.2	3.67	32.7	3.98	37.3	4.44	40.0	4.89
	12	20.3	2.39	24.2	2.61	28.2	2.90	30.2	3.74	32.7	4.06	37.3	4.52	40.0	4.97
	14	20.3	2.44	24.2	2.67	28.2	2.96	30.2	3.80	32.7	4.13	37.3	4.60	40.0	5.05
	16	20.3	2.48	24.2	2.73	28.2	3.03	30.2	3.87	32.7	4.21	37.3	4.68	40.0	5.15
	18	20.3	2.53	24.2	2.79	28.2	3.08	30.2	3.93	32.7	4.29	37.3	4.76	40.0	5.25
	20	20.3	2.59	24.2	2.88	28.2	3.15	30.2	4.01	32.7	4.32	37.3	4.86	40.0	5.35
	21	20.3	2.61	24.2	3.00	28.2	3.20	30.2	4.30	32.7	4.40	37.3	4.91	40.0	5.46
	23	20.3	2.79	24.2	3.24	28.2	3.44	30.2	4.60	32.7	4.68	37.3	5.10	40.0	5.51
	25	20.3	2.99	24.2	3.49	28.2	3.69	30.2	4.85	32.7	4.99	37.3	5.44	40.0	5.87
	27	20.3	3.20	24.2	3.75	28.2	3.95	30.2	5.09	32.7	5.31	37.3	5.80	40.0	6.26
	29	20.3	3.42	24.2	4.03	28.2	4.23	30.2	5.30	32.7	5.66	37.3	6.19	40.0	6.68
	31	20.3	3.66	24.2	4.32	28.2	4.52	30.2	5.60	32.7	6.01	37.3	6.58	40.0	7.13
	33	20.3	3.90	24.2	4.63	28.2	4.83	30.2	5.83	32.7	6.39	37.3	7.00	40.0	7.59
	35	20.3	4.16	24.2	4.97	28.2	5.16	30.2	5.88	32.7	6.78	37.3	7.46	40.0	8.09
	37	20.3	4.43	24.2	5.32	28.2	5.50	30.2	6.15	32.7	7.20	37.3	7.93	40.0	8.61
	39	20.3	4.72	24.2	5.68	28.2	5.86	30.2	6.39	32.7	7.46	37.3	8.42	40.0	9.17
	41	20.3	4.90	24.2	5.90	28.2	6.08	30.2	6.62	32.7	7.72	37.3	8.81	40.0	9.75
43	20.3	5.07	24.2	6.02	28.2	6.31	30.2	6.93	32.7	8.11	37.3	9.19	40.0	10.19	
45	20.3	5.48	24.2	6.77	28.2	7.16	30.2	7.55	32.7	8.76	37.3	9.60	40.0	10.63	
48	20.3	6.30	24.2	7.06	28.2	7.82	30.2	8.59	32.7	9.35	37.3	10.12	40.0	10.88	
50	20.3	7.11	24.2	7.87	28.2	8.64	30.2	9.40	32.7	10.17	37.3	10.93	40.0	11.70	
52	20.3	7.92	24.2	8.68	28.2	9.45	30.2	10.21	32.7	10.98	37.3	11.74	40.0	12.51	
54	20.3	8.73	24.2	9.50	28.2	10.26	30.2	11.03	32.7	11.79	37.3	12.55	40.0	13.32	

Обозначения:

CR: Индекс установленной мощности;

ТС: Полная производительность (кВт);

PI: Потребляемая мощность (компрессор + двигатель вентилятора наружного блока) (кВт)

Примечание: 1. В серых ячейках указаны расчётные значения.

Продолжение таблицы на следующей странице...

MVS FDC II-S

Таблица 2-8.1: Таблица холодопроизводительности для блоков производительностью 18 л.с. (продолжение)

CR	Температура наружного воздуха (°C DB)	Температура в помещении (°C DB/WD)													
		20.8/14		23.3/16		25.8/18		27/19		28.2/20		30.7/22		32/24	
		ТС	PI	ТС	PI	ТС	PI	ТС	PI	ТС	PI	ТС	PI	ТС	PI
		кВт	кВт	кВт	кВт	кВт	кВт	кВт	кВт	кВт	кВт	кВт	кВт	кВт	кВт
50%	-5	17.0	1.74	20.4	1.90	23.6	2.09	25.3	2.87	27.4	2.98	31.1	3.39	33.5	3.65
	-2	17.0	1.77	20.4	1.92	23.6	2.12	25.3	2.94	27.4	3.03	31.1	3.43	33.5	3.70
	0	17.0	1.79	20.4	1.95	23.6	2.16	25.3	2.96	27.4	3.07	31.1	3.49	33.5	3.77
	2	17.0	1.81	20.4	1.97	23.6	2.18	25.3	2.97	27.4	3.12	31.1	3.51	33.5	3.84
	4	17.0	1.83	20.4	2.01	23.6	2.22	25.3	2.97	27.4	3.19	31.1	3.60	33.5	3.94
	6	17.0	1.87	20.4	2.04	23.6	2.27	25.3	3.00	27.4	3.24	31.1	3.65	33.5	4.05
	8	17.0	1.90	20.4	2.08	23.6	2.31	25.3	3.01	27.4	3.29	31.1	3.71	33.5	4.18
	10	17.0	1.94	20.4	2.12	23.6	2.36	25.3	2.98	27.4	3.38	31.1	3.81	33.5	4.25
	12	17.0	1.98	20.4	2.16	23.6	2.41	25.3	3.00	27.4	3.45	31.1	3.87	33.5	4.31
	14	17.0	2.02	20.4	2.21	23.6	2.45	25.3	3.01	27.4	3.50	31.1	3.94	33.5	4.40
	16	17.0	2.06	20.4	2.26	23.6	2.50	25.3	3.02	27.4	3.55	31.1	4.01	33.5	4.47
	18	17.0	2.10	20.4	2.31	23.6	2.55	25.3	3.04	27.4	3.62	31.1	4.08	33.5	4.55
	20	17.0	2.14	20.4	2.39	23.6	2.60	25.3	3.18	27.4	3.69	31.1	4.14	33.5	4.63
	21	17.0	2.16	20.4	2.48	23.6	2.65	25.3	3.34	27.4	3.72	31.1	4.19	33.5	4.69
	23	17.0	2.31	20.4	2.68	23.6	2.85	25.3	3.56	27.4	3.79	31.1	4.26	33.5	4.79
	25	17.0	2.48	20.4	2.89	23.6	3.06	25.3	3.79	27.4	3.91	31.1	4.48	33.5	5.11
	27	17.0	2.65	20.4	3.11	23.6	3.27	25.3	4.09	27.4	4.14	31.1	4.77	33.5	5.45
	29	17.0	2.83	20.4	3.34	23.6	3.50	25.3	4.21	27.4	4.42	31.1	5.07	33.5	5.80
	31	17.0	3.03	20.4	3.58	23.6	3.74	25.3	4.49	27.4	4.69	31.1	5.40	33.5	6.17
	33	17.0	3.23	20.4	3.84	23.6	4.00	25.3	4.73	27.4	4.97	31.1	5.73	33.5	6.56
	35	17.0	3.44	20.4	4.11	23.6	4.27	25.3	4.87	27.4	5.26	31.1	6.09	33.5	6.97
37	17.0	3.67	20.4	4.40	23.6	4.56	25.3	5.09	27.4	5.58	31.1	6.46	33.5	7.41	
39	17.0	3.91	20.4	4.70	23.6	4.86	25.3	5.29	27.4	5.92	31.1	6.85	33.5	7.87	
41	17.0	4.05	20.4	4.89	23.6	5.04	25.3	5.48	27.4	6.18	31.1	7.22	33.5	8.23	
43	17.0	4.20	20.4	4.98	23.6	5.22	25.3	5.84	27.4	6.33	31.1	7.58	33.5	8.60	
45	17.0	4.39	20.4	5.61	23.6	5.98	25.3	6.45	27.4	7.08	31.1	8.31	33.5	8.96	
48	17.0	5.16	20.4	5.90	23.6	6.63	25.3	7.36	27.4	8.09	31.1	8.82	33.5	9.55	
50	17.0	5.93	20.4	6.66	23.6	7.40	25.3	8.13	27.4	8.86	31.1	9.59	33.5	10.32	
52	17.0	6.70	20.4	7.43	23.6	8.17	25.3	8.90	27.4	9.63	31.1	10.36	33.5	11.09	
54	17.0	7.47	20.4	8.20	23.6	8.93	25.3	9.67	27.4	10.40	31.1	11.13	33.5	11.86	

Обозначения:

CR: Индекс установленной мощности;

ТС: Полная производительность (кВт);

PI: Потребляемая мощность (компрессор + двигатель вентилятора наружного блока) (кВт)

Примечание: 1. В серых ячейках указаны расчётные значения.

Таблица 2-8.2: Таблица холодопроизводительности для блоков производительностью 20 л.с.

CR	Температура наружного воздуха(°C DB)	Температура в помещении (°C DB/WD)													
		20.8/14		23.3/16		25.8/18		27/19		28.2/20		30.7/22		32/24	
		ТС	PI	ТС	PI	ТС	PI	ТС	PI	ТС	PI	ТС	PI	ТС	PI
		кВт	кВт	кВт	кВт	кВт	кВт	кВт	кВт	кВт	кВт	кВт	кВт	кВт	кВт
130%	-5	50.7	6.62	61.7	7.41	69.6	8.00	71.6	8.68	76.5	9.26	78.6	10.07	79.2	10.14
	-2	50.7	6.62	61.7	7.57	69.6	8.00	72.2	8.73	76.5	9.26	78.6	10.20	79.2	10.24
	0	50.7	6.73	61.7	7.71	69.6	8.31	72.2	9.23	76.5	9.80	78.6	10.33	79.2	10.38
	2	50.7	6.85	61.7	7.73	69.6	8.62	72.2	9.77	76.5	9.91	78.6	10.40	79.2	10.53
	4	50.7	7.00	61.7	7.90	69.6	8.94	72.2	9.81	76.5	10.04	78.6	10.40	79.2	10.73
	6	50.7	7.14	61.7	8.07	69.6	9.30	72.2	9.89	75.2	10.36	76.3	10.39	79.2	10.81
	8	50.7	7.31	61.7	8.27	69.6	9.79	72.2	10.39	74.5	10.69	75.5	10.44	78.4	10.91
	10	50.7	7.46	61.7	8.46	69.6	10.18	72.2	10.75	73.7	10.77	75.3	10.77	77.4	11.23
	12	50.7	7.59	61.7	8.63	69.6	10.40	71.4	10.88	72.7	11.05	74.7	10.96	76.6	11.30
	14	50.7	7.74	61.7	8.81	69.1	10.44	70.8	10.93	71.8	11.15	74.1	11.15	75.6	11.56
	16	50.7	7.88	61.7	9.00	68.3	10.74	69.6	11.15	70.9	11.38	73.6	11.41	74.9	11.74
	18	50.7	8.03	61.7	9.20	67.3	10.90	68.4	11.30	70.0	11.69	73.1	11.80	74.2	11.91
	20	50.7	8.20	61.7	9.83	66.6	11.47	67.4	11.86	69.1	12.26	72.6	12.37	73.5	12.50
	21	50.7	8.42	61.7	10.20	66.3	11.75	67.6	12.15	68.2	12.54	72.0	12.67	72.8	12.78
	23	50.7	9.03	61.7	10.99	65.1	12.32	66.1	12.71	67.3	13.11	71.5	13.24	72.1	13.37
	25	50.7	9.64	61.7	11.82	64.0	12.89	65.2	13.28	66.4	13.70	71.0	13.83	71.4	13.96
	27	50.7	10.30	61.7	12.69	63.2	13.45	64.2	14.14	65.4	14.27	70.4	14.42	70.7	14.57
	29	50.7	10.99	61.7	13.61	62.2	14.02	63.3	14.90	64.5	14.86	69.9	15.01	70.0	15.16
	31	50.7	11.74	59.6	14.43	61.3	14.61	62.5	15.64	63.6	15.42	69.4	15.60	69.3	15.77
	33	50.7	12.50	58.5	15.00	60.4	15.18	61.4	16.49	62.7	16.01	68.9	16.19	68.6	16.36
	35	50.7	13.33	57.5	15.57	59.5	15.77	60.4	16.49	61.8	16.60	68.3	16.80	67.9	16.97
	37	50.7	14.18	56.7	16.27	58.5	16.36	59.6	16.77	60.9	17.21	67.8	17.41	67.2	17.61
	39	50.7	15.10	55.7	16.91	57.5	16.99	58.7	17.36	60.4	17.80	67.3	18.00	66.5	18.21
	41	50.7	15.89	55.1	17.56	56.9	17.63	57.8	17.95	58.7	18.30	60.6	18.48	65.8	18.71
	43	50.7	16.52	54.7	18.21	56.6	18.77	56.8	19.03	58.1	19.23	59.5	19.39	65.1	19.58
45	50.7	17.14	54.4	19.02	56.0	19.57	55.9	19.95	57.3	20.14	57.9	20.27	64.4	20.70	
48	50.7	19.42	54.0	19.92	55.4	20.41	55.0	20.91	56.5	21.40	56.2	21.90	63.7	22.39	
50	50.7	21.70	52.4	22.20	54.2	22.69	54.0	23.19	55.4	23.68	52.8	24.18	63.0	24.67	
52	50.7	23.98	51.6	24.47	53.5	24.97	53.1	25.47	54.5	25.96	50.3	26.46	62.3	26.95	
54	50.7	26.26	50.7	26.75	52.7	27.25	52.2	27.74	53.6	28.24	47.8	28.74	61.6	29.23	
120%	-5	47.4	6.38	55.0	6.91	64.0	8.00	69.6	8.99	72.9	9.57	74.6	10.40	76.2	10.68
	-2	47.4	6.45	55.0	6.99	64.0	8.09	69.6	9.04	72.9	9.70	74.6	10.49	76.2	10.72
	0	47.4	6.50	55.0	7.05	64.0	8.19	69.6	9.07	72.9	9.79	74.6	10.55	76.2	10.74
	2	47.4	6.52	55.0	7.13	64.0	8.26	69.6	9.17	72.9	9.83	74.6	10.63	76.2	10.76
	4	47.4	6.59	55.0	7.23	64.0	8.39	69.6	9.26	72.9	9.97	74.6	10.65	76.2	10.80
	6	47.4	6.66	55.0	7.29	64.0	8.50	69.6	9.37	72.9	10.09	74.6	10.74	76.2	10.83
	8	47.4	6.72	55.0	7.37	64.0	8.63	69.6	9.50	72.9	10.20	74.6	10.78	76.2	10.88
	10	47.4	6.80	55.0	7.48	64.0	8.72	69.6	9.69	72.9	10.21	74.6	10.81	76.2	10.93
	12	47.4	6.93	55.0	7.63	64.0	8.92	69.6	9.89	71.9	10.25	73.6	10.75	75.2	11.01
	14	47.4	7.06	55.0	7.81	64.0	9.11	69.6	10.11	70.9	10.32	72.7	10.92	74.4	11.14
	16	47.4	7.19	55.0	7.98	64.0	9.31	69.5	10.25	70.1	10.49	71.7	11.11	73.3	11.31
	18	47.4	7.32	55.0	8.16	64.0	9.66	68.1	10.56	69.1	10.77	70.7	11.37	72.5	11.48
	20	47.4	7.47	55.0	8.50	64.0	10.49	67.4	11.13	68.3	11.34	69.9	11.94	71.5	12.05
	21	47.4	7.54	55.0	8.83	64.0	10.90	66.2	11.82	67.6	11.62	69.5	12.22	71.1	12.35
	23	47.4	8.06	55.0	9.53	64.0	11.75	64.8	12.76	66.8	12.19	68.5	12.81	70.1	12.92
	25	47.4	8.61	55.0	10.25	63.0	12.32	64.0	13.31	65.8	12.75	67.6	13.38	69.3	13.51
	27	47.4	9.19	55.0	11.01	62.2	12.86	63.1	14.18	65.0	13.34	66.6	13.96	68.3	14.10
	29	47.4	9.80	55.0	11.82	61.2	13.43	62.0	14.78	64.0	13.91	65.6	14.55	67.4	14.68
	31	47.4	10.46	55.0	12.67	60.2	14.02	61.2	15.51	63.2	14.50	64.8	15.14	66.4	15.29
	33	47.4	11.13	55.0	13.56	59.3	14.58	60.2	16.17	62.1	15.06	63.8	15.73	65.4	15.88
	35	47.4	11.85	55.0	14.52	58.4	15.15	59.1	16.38	61.3	15.65	63.0	16.32	64.6	16.49
	37	47.4	12.61	55.0	15.52	57.5	15.74	58.4	16.48	59.7	16.58	61.9	16.91	63.6	17.10
	39	47.4	13.42	54.8	16.44	56.5	16.31	57.3	16.58	58.7	16.83	61.1	17.52	62.7	17.69
	41	47.4	14.16	54.4	16.56	56.0	16.88	56.8	17.36	57.7	17.42	59.5	18.10	61.0	18.29
	43	47.4	14.78	54.1	16.68	55.6	17.35	56.4	17.74	57.2	18.00	58.5	18.69	60.0	18.89
45	47.4	15.41	53.8	16.85	55.1	17.70	55.8	18.36	56.7	18.59	57.3	19.29	59.6	19.50	
48	47.4	17.67	53.5	18.16	54.6	18.65	55.3	19.14	56.2	19.63	56.2	20.12	58.9	20.62	
50	47.4	19.93	53.2	20.42	53.9	20.91	54.7	21.40	55.3	21.89	54.9	22.39	57.6	22.88	
52	47.4	22.19	52.8	22.68	53.4	23.17	54.1	23.66	54.7	24.15	53.8	24.65	56.6	25.14	
54	47.4	24.45	52.5	24.94	52.8	25.43	53.5	25.92	54.0	26.42	52.6	26.91	55.7	27.40	

Обозначения:

CR: Индекс установленной мощности;
 ТС: Полная производительность (кВт);
 PI: Потребляемая мощность (компрессор + двигатель вентилятора наружного блока) (кВт)

Примечание: 1. В серых ячейках указаны расчётные значения.

Продолжение таблицы на следующей странице...

Dantex MVS FDC II-S серия. Техническая инструкция

MVS FDC II-S

Таблица 2-8.2: Таблица холодопроизводительности для блоков производительностью 20 л.с. (продолжение)

CR	Температура наружного воздуха (°C DB)	Температура в помещении (°C DB/WD)													
		20.8/14		23.3/16		25.8/18		27/19		28.2/20		30.7/22		32/24	
		ТС	PI	ТС	PI	ТС	PI	ТС	PI	ТС	PI	ТС	PI	ТС	PI
		кВт	кВт	кВт	кВт	кВт	кВт	кВт	кВт	кВт	кВт	кВт	кВт	кВт	кВт
110%	-5	43.8	5.58	50.6	6.29	61.2	7.47	63.2	8.40	68.0	9.24	73.2	9.61	74.8	10.25
	-2	43.8	5.68	50.6	6.38	61.2	7.54	63.2	8.49	68.0	9.32	73.2	9.71	74.8	10.30
	0	43.8	5.74	50.6	6.42	61.2	7.60	63.2	8.55	68.0	9.43	73.2	9.81	74.8	10.42
	2	43.8	5.87	50.6	6.49	61.2	7.74	63.2	8.65	68.0	9.53	73.2	9.96	74.8	10.55
	4	43.8	5.98	50.6	6.57	61.2	7.82	63.2	8.76	68.0	9.68	73.2	10.10	74.8	10.65
	6	43.8	6.04	50.6	6.65	61.2	7.90	63.2	8.91	68.0	9.79	73.2	10.21	74.8	10.82
	8	43.8	6.10	50.6	6.77	61.2	8.00	63.2	9.01	68.0	9.91	73.2	10.28	74.8	10.93
	10	43.8	6.17	50.6	6.87	61.2	8.13	63.2	9.17	68.0	10.08	73.2	10.35	74.8	11.02
	12	43.8	6.30	50.6	7.02	61.2	8.30	63.2	9.37	68.0	10.27	72.3	10.51	73.8	11.17
	14	43.8	6.41	50.6	7.16	61.2	8.47	63.2	9.54	68.0	10.47	71.3	10.60	72.9	11.25
	16	43.8	6.52	50.6	7.31	61.2	8.65	63.2	9.74	68.0	10.68	70.5	10.73	71.9	11.37
	18	43.8	6.65	50.6	7.46	61.2	8.84	63.2	10.02	68.0	11.21	69.5	11.30	71.1	11.73
	20	43.8	6.78	50.6	7.63	61.2	9.41	63.2	10.81	67.0	11.78	68.7	11.86	70.1	12.30
	21	43.8	6.85	50.6	7.87	61.2	9.78	63.2	11.65	66.6	12.06	68.1	12.15	69.7	12.58
	23	43.8	7.17	50.6	8.48	61.2	10.55	63.2	12.40	65.6	12.60	67.2	12.73	68.7	13.17
	25	43.8	7.65	50.6	9.12	61.2	11.33	63.2	13.23	64.8	13.17	66.2	13.30	67.8	13.74
	27	43.8	8.16	50.6	9.79	61.2	12.18	62.4	13.88	63.8	13.74	65.4	13.87	66.8	14.33
	29	43.8	8.70	50.6	10.49	61.2	13.07	61.2	14.68	63.0	14.33	64.4	14.46	66.0	14.91
	31	43.8	9.27	50.6	11.23	61.2	14.01	60.1	15.49	61.9	14.89	63.6	15.02	65.0	15.50
	33	43.8	9.86	50.6	12.02	61.2	14.82	59.7	16.09	61.1	15.46	62.5	15.61	64.2	16.09
	35	43.8	10.49	50.6	12.84	57.9	15.39	58.1	16.29	60.1	16.05	61.5	16.20	63.2	16.68
	37	43.8	11.48	50.6	13.72	56.5	15.98	57.5	16.37	59.1	16.62	60.7	16.79	62.1	17.27
	39	43.8	12.46	50.6	14.66	55.5	16.54	56.4	16.96	58.1	17.21	59.7	17.38	61.3	17.88
	41	43.8	13.44	50.6	14.78	54.5	16.66	55.8	17.08	57.1	17.33	57.8	17.58	59.5	18.00
	43	43.8	14.42	50.6	14.98	53.4	16.79	55.2	17.20	56.1	17.45	57.3	18.04	58.6	18.37
	45	43.8	15.24	50.6	15.51	52.4	17.13	54.3	17.56	55.2	17.80	55.8	18.44	57.3	18.98
48	43.8	17.49	50.6	17.97	51.4	18.46	53.5	18.95	54.2	19.44	55.2	19.93	56.1	20.42	
50	43.8	19.73	49.4	20.22	50.4	20.71	52.7	21.20	53.3	21.69	53.9	22.18	54.8	22.67	
52	43.8	21.98	48.3	22.47	49.4	22.96	51.9	23.45	52.3	23.94	52.9	24.42	53.6	24.91	
54	43.8	24.23	47.2	24.72	48.4	25.21	51.1	25.70	51.4	26.18	51.8	26.67	52.4	27.16	
100%	-5	39.3	5.73	46.1	6.24	55.2	6.88	56.0	8.08	60.7	7.89	69.8	8.74	71.9	9.63
	-2	39.3	5.81	46.1	6.32	55.2	7.02	56.0	8.14	60.7	8.00	69.8	8.85	71.9	9.70
	0	39.3	5.87	46.1	6.40	55.2	7.14	56.0	8.26	60.7	8.08	69.8	9.01	71.9	9.81
	2	39.3	5.96	46.1	6.48	55.2	7.30	56.0	8.34	60.7	8.18	69.8	9.15	71.9	9.97
	4	39.3	6.02	46.1	6.59	55.2	7.39	56.0	8.46	60.7	8.29	69.8	9.25	71.9	10.08
	6	39.3	6.14	46.1	6.69	55.2	7.52	56.0	8.64	60.7	8.42	69.8	9.39	71.9	10.24
	8	39.3	6.24	46.1	6.83	55.2	7.66	56.0	8.80	60.7	8.56	69.8	9.55	71.9	10.42
	10	39.3	6.36	46.1	6.95	55.2	7.78	56.0	8.93	60.7	8.73	69.8	9.72	71.9	10.57
	12	39.3	6.49	46.1	7.10	55.2	8.08	56.0	9.11	60.7	8.90	69.8	9.92	70.9	10.65
	14	39.3	6.62	46.1	7.26	55.2	8.45	56.0	9.69	60.7	9.07	69.8	10.13	70.1	10.79
	16	39.3	6.75	46.1	7.43	55.2	8.66	56.0	9.94	60.7	9.27	67.7	10.26	69.1	10.92
	18	39.3	6.88	46.1	7.58	55.2	8.99	56.0	10.33	60.7	9.46	66.9	10.63	68.3	11.20
	20	39.3	7.03	46.1	7.84	55.2	9.74	56.0	11.03	60.7	10.17	65.9	11.17	67.3	11.76
	21	39.3	7.10	46.1	8.16	55.2	10.43	56.0	11.70	60.7	10.54	65.5	11.45	66.9	12.04
	23	39.3	7.59	46.1	8.81	55.2	11.22	56.0	12.51	60.7	11.34	64.7	12.01	65.9	12.60
	25	39.3	8.13	46.1	9.50	55.2	12.11	56.0	13.14	60.7	12.18	63.7	12.57	65.1	13.16
	27	39.3	8.69	46.1	10.21	55.2	12.82	56.0	13.93	60.7	13.06	62.7	13.13	64.1	13.74
	29	39.3	9.30	46.1	10.96	55.2	13.79	56.0	14.34	60.5	13.90	61.9	14.19	63.3	14.30
	31	39.3	9.94	46.1	11.76	55.2	14.74	56.0	14.60	59.7	14.46	60.9	14.70	62.3	14.88
	33	39.3	10.61	46.1	12.60	55.2	15.45	56.0	15.01	58.7	15.02	60.1	15.24	61.5	15.46
	35	39.3	11.30	46.1	13.51	55.2	15.76	56.0	16.00	57.7	16.03	59.1	16.19	60.5	16.35
	37	39.3	12.06	46.1	14.46	55.2	15.88	55.3	16.73	57.1	16.97	58.3	17.18	59.5	17.41
	39	39.3	12.83	46.1	15.45	55.2	16.16	54.6	17.38	56.4	17.67	57.3	18.02	58.7	18.17
	41	39.3	13.31	46.1	16.05	55.2	16.40	53.9	18.00	55.6	18.37	55.2	18.54	57.9	18.74
	43	39.3	13.79	46.1	16.36	55.2	16.95	53.7	18.86	54.8	19.16	55.6	19.48	55.8	19.63
	45	39.3	14.43	46.1	16.82	55.2	18.01	53.3	20.05	54.0	21.16	55.1	22.22	54.9	22.65
48	39.3	16.64	46.1	17.92	55.2	19.20	52.7	21.60	53.2	22.88	53.8	24.16	54.0	25.44	
50	39.3	18.85	46.1	20.13	55.2	21.41	52.2	22.69	52.5	23.97	53.0	25.25	53.2	26.53	
52	39.3	21.06	46.1	22.34	55.2	23.62	51.8	24.90	51.7	26.18	52.2	27.46	52.4	28.74	
54	39.3	23.27	46.1	24.55	55.2	25.83	51.3	27.11	50.9	28.39	51.4	29.67	51.6	30.95	

Обозначения:

- CR: Индекс установленной мощности;
- ТС: Полная производительность (кВт);
- PI: Потребляемая мощность (компрессор + двигатель вентилятора наружного блока) (кВт)

Примечание: 1. В серых ячейках указаны расчётные значения.

Продолжение таблицы на следующей странице...

Таблица 2-8.2: Таблица холодопроизводительности для блоков производительностью 20 л.с. (продолжение)

CR	Температура наружного воздуха (°C DB)	Температура в помещении (°C DB/WD)													
		20.8/14		23.3/16		25.8/18		27/19		28.2/20		30.7/22		32/24	
		ТС	PI	ТС	PI	ТС	PI	ТС	PI	ТС	PI	ТС	PI	ТС	PI
		кВт	кВт	кВт	кВт	кВт	кВт	кВт	кВт	кВт	кВт	кВт	кВт	кВт	кВт
90%	-5	34.1	4.58	40.7	4.99	47.4	5.51	50.6	6.46	54.8	6.31	62.4	6.99	67.0	7.71
	-2	34.1	4.65	40.7	5.06	47.4	5.62	50.6	6.51	54.8	6.40	62.4	7.08	67.0	7.76
	0	34.1	4.70	40.7	5.12	47.4	5.71	50.6	6.61	54.8	6.46	62.4	7.21	67.0	7.85
	2	34.1	4.77	40.7	5.18	47.4	5.84	50.6	6.67	54.8	6.54	62.4	7.32	67.0	7.97
	4	34.1	4.81	40.7	5.27	47.4	5.91	50.6	6.77	54.8	6.63	62.4	7.40	67.0	8.06
	6	34.1	4.92	40.7	5.35	47.4	6.02	50.6	6.91	54.8	6.73	62.4	7.51	67.0	8.19
	8	34.1	4.99	40.7	5.46	47.4	6.13	50.6	7.04	54.8	6.85	62.4	7.64	67.0	8.33
	10	34.1	5.09	40.7	5.56	47.4	6.23	50.6	7.15	54.8	6.98	62.4	7.78	67.0	8.46
	12	34.1	5.20	40.7	5.68	47.4	6.46	50.6	7.29	54.8	7.12	62.4	7.93	67.0	8.52
	14	34.1	5.30	40.7	5.80	47.4	6.76	50.6	7.75	54.8	7.26	62.4	8.10	67.0	8.63
	16	34.1	5.40	40.7	5.94	47.4	6.93	50.6	7.95	54.8	7.41	62.4	8.21	67.0	8.73
	18	34.1	5.51	40.7	6.06	47.4	7.19	50.6	8.26	54.8	7.57	62.4	8.50	67.0	8.96
	20	34.1	5.63	40.7	6.27	47.4	7.79	50.6	8.83	54.8	8.14	62.4	8.93	67.0	9.40
	21	34.1	5.68	40.7	6.53	47.4	8.35	50.6	9.36	54.8	8.43	62.4	9.16	67.0	9.63
	23	34.1	6.07	40.7	7.05	47.4	8.98	50.6	10.01	54.8	9.07	62.4	9.61	67.0	10.08
	25	34.1	6.51	40.7	7.60	47.4	9.69	50.6	10.51	54.8	9.74	62.4	10.06	67.0	10.53
	27	34.1	6.95	40.7	8.17	47.4	10.26	50.6	11.14	54.8	10.45	62.4	10.50	67.0	10.99
	29	34.1	7.44	40.7	8.77	47.4	11.03	50.6	11.47	54.8	11.12	62.4	11.35	67.0	11.44
	31	34.1	7.96	40.7	9.41	47.4	11.80	50.6	11.68	54.8	11.57	62.4	11.76	67.0	11.91
	33	34.1	8.49	40.7	10.08	47.4	12.36	50.6	12.01	54.8	12.02	62.4	12.19	67.0	12.37
	35	34.1	9.04	40.7	10.81	47.4	12.61	50.6	12.80	54.8	12.82	62.4	12.95	67.0	13.08
	37	34.1	9.65	40.7	11.57	47.4	12.70	50.6	13.37	54.8	13.57	62.4	13.74	67.0	13.93
	39	34.1	10.27	40.7	12.36	47.4	12.93	50.6	13.59	54.8	14.14	62.4	14.42	67.0	14.54
	41	34.1	10.65	40.7	12.84	47.4	13.12	50.6	13.84	54.8	14.70	62.4	14.84	67.0	14.99
43	34.1	11.03	40.7	13.09	47.4	13.56	50.6	14.11	54.8	15.32	62.4	15.59	67.0	15.71	
45	34.1	11.55	40.7	13.46	47.4	14.41	50.6	14.36	54.8	15.65	62.4	16.24	67.0	16.58	
48	34.1	13.31	40.7	13.95	47.4	14.59	50.6	15.23	54.8	15.87	62.4	16.51	67.0	17.15	
50	34.1	15.08	40.7	15.72	47.4	16.36	50.6	17.00	54.8	17.64	62.4	18.28	67.0	18.92	
52	34.1	16.85	40.7	17.49	47.4	18.13	50.6	18.77	54.8	19.41	62.4	20.05	67.0	20.69	
54	34.1	18.61	40.7	19.25	47.4	19.89	50.6	20.53	54.8	21.17	62.4	21.81	67.0	22.45	
80%	-5	30.4	3.51	36.2	3.62	42.1	4.21	45.1	3.93	49.0	5.23	55.7	6.01	59.8	6.89
	-2	30.4	3.56	36.2	3.66	42.1	4.27	45.1	3.94	49.0	5.29	55.7	6.07	59.8	6.95
	0	30.4	3.59	36.2	3.71	42.1	4.34	45.1	4.03	49.0	5.36	55.7	6.14	59.8	7.01
	2	30.4	3.65	36.2	3.76	42.1	4.39	45.1	4.20	49.0	5.45	55.7	6.27	59.8	7.11
	4	30.4	3.68	36.2	3.82	42.1	4.47	45.1	4.21	49.0	5.51	55.7	6.37	59.8	7.22
	6	30.4	3.76	36.2	3.90	42.1	4.55	45.1	4.33	49.0	5.61	55.7	6.47	59.8	7.34
	8	30.4	3.82	36.2	3.98	42.1	4.65	45.1	4.49	49.0	5.71	55.7	6.59	59.8	7.41
	10	30.4	3.90	36.2	4.07	42.1	4.74	45.1	4.54	49.0	5.84	55.7	6.67	59.8	7.52
	12	30.4	3.98	36.2	4.15	42.1	4.84	45.1	4.66	49.0	5.95	55.7	6.80	59.8	7.66
	14	30.4	4.06	36.2	4.22	42.1	4.93	45.1	4.75	49.0	6.06	55.7	6.92	59.8	7.80
	16	30.4	4.13	36.2	4.30	42.1	5.04	45.1	4.87	49.0	6.18	55.7	7.06	59.8	7.94
	18	30.4	4.21	36.2	4.39	42.1	5.13	45.1	5.04	49.0	6.30	55.7	7.20	59.8	8.19
	20	30.4	4.31	36.2	4.50	42.1	5.24	45.1	5.48	49.0	6.54	55.7	7.74	59.8	8.57
	21	30.4	4.35	36.2	4.53	42.1	5.33	45.1	5.89	49.0	6.77	55.7	8.02	59.8	8.78
	23	30.4	4.65	36.2	4.72	42.1	5.73	45.1	6.39	49.0	7.26	55.7	8.61	59.8	9.18
	25	30.4	4.98	36.2	5.06	42.1	6.15	45.1	6.87	49.0	7.76	55.7	9.21	59.8	9.58
	27	30.4	5.32	36.2	5.40	42.1	6.58	45.1	7.53	49.0	8.30	55.7	9.86	59.8	9.98
	29	30.4	5.69	36.2	5.77	42.1	7.04	45.1	7.85	49.0	8.87	55.7	10.31	59.8	10.38
	31	30.4	6.09	36.2	6.15	42.1	7.52	45.1	8.39	49.0	9.46	55.7	10.71	59.8	10.80
	33	30.4	6.50	36.2	6.56	42.1	8.05	45.1	8.94	49.0	10.09	55.7	11.12	59.8	11.20
	35	30.4	6.92	36.2	6.99	42.1	8.59	45.1	9.80	49.0	10.75	55.7	11.53	59.8	11.62
	37	30.4	7.38	36.2	7.44	42.1	9.16	45.1	10.24	49.0	11.46	55.7	11.93	59.8	12.02
	39	30.4	7.86	36.2	7.93	42.1	9.76	45.1	10.64	49.0	12.23	55.7	12.34	59.8	12.44
	41	30.4	8.15	36.2	8.30	42.1	10.13	45.1	11.02	49.0	12.28	55.7	12.66	59.8	12.73
43	30.4	8.44	36.2	8.67	42.1	10.50	45.1	11.54	49.0	12.54	55.7	12.82	59.8	12.93	
45	30.4	8.84	36.2	9.11	42.1	10.94	45.1	12.28	49.0	12.89	55.7	12.96	59.8	13.10	
48	30.4	10.19	36.2	10.97	42.1	11.76	45.1	12.54	49.0	13.32	55.7	14.11	59.8	14.89	
50	30.4	11.54	36.2	12.32	42.1	13.11	45.1	13.89	49.0	14.67	55.7	15.46	59.8	16.24	
52	30.4	12.89	36.2	13.68	42.1	14.46	45.1	15.24	49.0	16.03	55.7	16.81	59.8	17.59	
54	30.4	14.24	36.2	15.03	42.1	15.81	45.1	16.59	49.0	17.38	55.7	18.16	59.8	18.94	

Обозначения:

CR: Индекс установленной мощности;

ТС: Полная производительность (кВт);

PI: Потребляемая мощность (компрессор + двигатель вентилятора наружного блока) (кВт)

Примечание: 1. В серых ячейках указаны расчётные значения.

Продолжение таблицы на следующей странице...

MVS FDC II-S

Таблица 2-8.2: Таблица холодопроизводительности для блоков производительностью 20 л.с. (продолжение)

CR	Температура наружного воздуха (°C DB)	Температура в помещении (°CDB/WD)													
		20.8/14		23.3/16		25.8/18		27/19		28.2/20		30.7/22		32/24	
		ТС	PI	ТС	PI	ТС	PI	ТС	PI	ТС	PI	ТС	PI	ТС	PI
		кВт	кВт	кВт	кВт	кВт	кВт	кВт	кВт	кВт	кВт	кВт	кВт	кВт	кВт
70%	-5	26.6	2.84	31.9	2.94	36.9	3.42	39.5	3.94	42.9	4.24	48.8	4.88	52.4	5.58
	-2	26.6	2.88	31.9	2.97	36.9	3.46	39.5	3.96	42.9	4.29	48.8	4.92	52.4	5.64
	0	26.6	2.91	31.9	3.01	36.9	3.52	39.5	3.98	42.9	4.35	48.8	4.98	52.4	5.68
	2	26.6	2.96	31.9	3.05	36.9	3.56	39.5	4.09	42.9	4.42	48.8	5.08	52.4	5.77
	4	26.6	2.99	31.9	3.10	36.9	3.62	39.5	4.15	42.9	4.47	48.8	5.16	52.4	5.85
	6	26.6	3.05	31.9	3.16	36.9	3.69	39.5	4.23	42.9	4.55	48.8	5.24	52.4	5.95
	8	26.6	3.10	31.9	3.22	36.9	3.77	39.5	4.31	42.9	4.63	48.8	5.34	52.4	6.00
	10	26.6	3.16	31.9	3.30	36.9	3.85	39.5	4.38	42.9	4.74	48.8	5.41	52.4	6.10
	12	26.6	3.22	31.9	3.36	36.9	3.92	39.5	4.46	42.9	4.82	48.8	5.51	52.4	6.21
	14	26.6	3.29	31.9	3.42	36.9	4.00	39.5	4.61	42.9	4.91	48.8	5.61	52.4	6.33
	16	26.6	3.35	31.9	3.49	36.9	4.08	39.5	4.62	42.9	5.01	48.8	5.72	52.4	6.44
	18	26.6	3.42	31.9	3.56	36.9	4.16	39.5	4.64	42.9	5.11	48.8	5.84	52.4	6.64
	20	26.6	3.49	31.9	3.65	36.9	4.25	39.5	4.94	42.9	5.30	48.8	6.28	52.4	6.95
	21	26.6	3.52	31.9	3.67	36.9	4.32	39.5	5.29	42.9	5.49	48.8	6.50	52.4	7.12
	23	26.6	3.77	31.9	3.83	36.9	4.65	39.5	5.58	42.9	5.89	48.8	6.98	52.4	7.44
	25	26.6	4.04	31.9	4.10	36.9	4.99	39.5	5.99	42.9	6.29	48.8	7.47	52.4	7.77
	27	26.6	4.32	31.9	4.38	36.9	5.34	39.5	6.42	42.9	6.73	48.8	7.99	52.4	8.09
	29	26.6	4.62	31.9	4.68	36.9	5.71	39.5	6.72	42.9	7.19	48.8	8.36	52.4	8.42
	31	26.6	4.94	31.9	4.99	36.9	6.10	39.5	7.16	42.9	7.67	48.8	8.68	52.4	8.76
	33	26.6	5.27	31.9	5.32	36.9	6.53	39.5	7.59	42.9	8.18	48.8	9.02	52.4	9.08
	35	26.6	5.61	31.9	5.67	36.9	6.96	39.5	7.94	42.9	8.72	48.8	9.35	52.4	9.42
	37	26.6	5.99	31.9	6.03	36.9	7.43	39.5	8.30	42.9	9.29	48.8	9.67	52.4	9.75
	39	26.6	6.37	31.9	6.43	36.9	7.92	39.5	8.63	42.9	9.91	48.8	10.01	52.4	10.08
	41	26.6	6.61	31.9	6.73	36.9	8.21	39.5	8.94	42.9	9.96	48.8	10.26	52.4	10.32
43	26.6	6.85	31.9	7.03	36.9	8.51	39.5	9.36	42.9	10.17	48.8	10.40	52.4	10.48	
45	26.6	7.16	31.9	7.38	36.9	8.87	39.5	9.95	42.9	10.45	48.8	11.30	52.4	11.78	
48	26.6	8.26	31.9	9.06	36.9	9.85	39.5	10.64	42.9	11.44	48.8	12.23	52.4	13.03	
50	26.6	9.36	31.9	10.15	36.9	10.95	39.5	11.74	42.9	12.53	48.8	13.33	52.4	14.12	
52	26.6	10.45	31.9	11.25	36.9	12.04	39.5	12.84	42.9	13.63	48.8	14.42	52.4	15.22	
54	26.6	11.55	31.9	12.34	36.9	13.14	39.5	13.93	42.9	14.73	48.8	15.52	52.4	16.31	
60%	-5	22.7	2.29	27.1	2.50	31.6	2.75	33.8	3.52	36.7	3.84	41.8	4.27	44.8	4.90
	-2	22.7	2.32	27.1	2.53	31.6	2.79	33.8	3.57	36.7	3.91	41.8	4.33	44.8	4.93
	0	22.7	2.35	27.1	2.56	31.6	2.84	33.8	3.62	36.7	3.96	41.8	4.40	44.8	4.99
	2	22.7	2.38	27.1	2.59	31.6	2.87	33.8	3.69	36.7	4.02	41.8	4.49	44.8	5.06
	4	22.7	2.41	27.1	2.64	31.6	2.92	33.8	3.73	36.7	4.10	41.8	4.56	44.8	5.13
	6	22.7	2.46	27.1	2.68	31.6	2.98	33.8	3.82	36.7	4.18	41.8	4.65	44.8	5.25
	8	22.7	2.50	27.1	2.73	31.6	3.04	33.8	3.89	36.7	4.26	41.8	4.74	44.8	5.33
	10	22.7	2.55	27.1	2.78	31.6	3.10	33.8	4.00	36.7	4.33	41.8	4.83	44.8	5.32
	12	22.7	2.60	27.1	2.84	31.6	3.16	33.8	4.07	36.7	4.42	41.8	4.92	44.8	5.41
	14	22.7	2.65	27.1	2.90	31.6	3.22	33.8	4.14	36.7	4.49	41.8	5.01	44.8	5.50
	16	22.7	2.70	27.1	2.97	31.6	3.29	33.8	4.21	36.7	4.58	41.8	5.09	44.8	5.61
	18	22.7	2.75	27.1	3.03	31.6	3.35	33.8	4.28	36.7	4.67	41.8	5.18	44.8	5.71
	20	22.7	2.81	27.1	3.14	31.6	3.42	33.8	4.37	36.7	4.71	41.8	5.29	44.8	5.82
	21	22.7	2.84	27.1	3.27	31.6	3.48	33.8	4.68	36.7	4.79	41.8	5.34	44.8	5.94
	23	22.7	3.04	27.1	3.52	31.6	3.75	33.8	5.00	36.7	5.09	41.8	5.55	44.8	6.00
	25	22.7	3.25	27.1	3.80	31.6	4.02	33.8	5.28	36.7	5.43	41.8	5.93	44.8	6.39
	27	22.7	3.48	27.1	4.09	31.6	4.30	33.8	5.54	36.7	5.78	41.8	6.31	44.8	6.81
	29	22.7	3.72	27.1	4.39	31.6	4.61	33.8	5.77	36.7	6.16	41.8	6.74	44.8	7.27
	31	22.7	3.98	27.1	4.71	31.6	4.92	33.8	6.09	36.7	6.54	41.8	7.16	44.8	7.77
	33	22.7	4.25	27.1	5.04	31.6	5.26	33.8	6.35	36.7	6.95	41.8	7.62	44.8	8.26
	35	22.7	4.52	27.1	5.41	31.6	5.61	33.8	6.40	36.7	7.38	41.8	8.12	44.8	8.81
	37	22.7	4.83	27.1	5.79	31.6	5.99	33.8	6.69	36.7	7.84	41.8	8.63	44.8	9.37
	39	22.7	5.14	27.1	6.18	31.6	6.38	33.8	6.95	36.7	8.12	41.8	9.16	44.8	9.98
	41	22.7	5.33	27.1	6.42	31.6	6.62	33.8	7.20	36.7	8.41	41.8	9.59	44.8	10.61
43	22.7	5.52	27.1	6.55	31.6	6.86	33.8	7.55	36.7	8.82	41.8	10.00	44.8	11.09	
45	22.7	5.97	27.1	7.37	31.6	7.79	33.8	8.22	36.7	9.54	41.8	10.45	44.8	11.57	
48	22.7	6.85	27.1	7.68	31.6	8.52	33.8	9.35	36.7	10.18	41.8	11.01	44.8	11.85	
50	22.7	7.74	27.1	8.57	31.6	9.40	33.8	10.23	36.7	11.07	41.8	11.90	44.8	12.73	
52	22.7	8.62	27.1	9.45	31.6	10.28	33.8	11.12	36.7	11.95	41.8	12.78	44.8	13.61	
54	22.7	9.50	27.1	10.34	31.6	11.17	33.8	12.00	36.7	12.83	41.8	13.67	44.8	14.50	

Обозначения:

CR: Индекс установленной мощности;
 ТС: Полная производительность (кВт);
 PI: Потребляемая мощность (компрессор + двигатель вентилятора наружного блока) (кВт)

Примечание: 1. В серых ячейках указаны расчётные значения.

Продолжение таблицы на следующей странице...

Таблица 2-8.2: Таблица холодопроизводительности для блоков производительностью 20 л.с. (продолжение)

CR	Температура наружного воздуха (°C DB)	Температура в помещении (°C DB/WD)													
		20.8/14		23.3/16		25.8/18		27/19		28.2/20		30.7/22		32/24	
		ТС	PI	ТС	PI	ТС	PI	ТС	PI	ТС	PI	ТС	PI	ТС	PI
50%	-5	19.1	1.90	22.8	2.07	26.5	2.28	28.3	3.13	30.7	3.25	34.9	3.69	37.6	3.98
	-2	19.1	1.92	22.8	2.09	26.5	2.31	28.3	3.20	30.7	3.30	34.9	3.74	37.6	4.03
	0	19.1	1.95	22.8	2.12	26.5	2.35	28.3	3.22	30.7	3.34	34.9	3.80	37.6	4.10
	2	19.1	1.97	22.8	2.15	26.5	2.38	28.3	3.23	30.7	3.40	34.9	3.82	37.6	4.18
	4	19.1	1.99	22.8	2.18	26.5	2.42	28.3	3.24	30.7	3.47	34.9	3.91	37.6	4.28
	6	19.1	2.04	22.8	2.22	26.5	2.47	28.3	3.26	30.7	3.53	34.9	3.97	37.6	4.41
	8	19.1	2.07	22.8	2.26	26.5	2.52	28.3	3.28	30.7	3.58	34.9	4.04	37.6	4.55
	10	19.1	2.11	22.8	2.30	26.5	2.57	28.3	3.25	30.7	3.68	34.9	4.14	37.6	4.62
	12	19.1	2.15	22.8	2.35	26.5	2.62	28.3	3.27	30.7	3.76	34.9	4.22	37.6	4.69
	14	19.1	2.20	22.8	2.40	26.5	2.67	28.3	3.28	30.7	3.81	34.9	4.29	37.6	4.79
	16	19.1	2.24	22.8	2.46	26.5	2.73	28.3	3.29	30.7	3.87	34.9	4.36	37.6	4.86
	18	19.1	2.28	22.8	2.51	26.5	2.78	28.3	3.30	30.7	3.94	34.9	4.44	37.6	4.95
	20	19.1	2.33	22.8	2.60	26.5	2.84	28.3	3.46	30.7	4.01	34.9	4.51	37.6	5.04
	21	19.1	2.35	22.8	2.70	26.5	2.89	28.3	3.63	30.7	4.05	34.9	4.57	37.6	5.10
	23	19.1	2.52	22.8	2.92	26.5	3.10	28.3	3.88	30.7	4.12	34.9	4.64	37.6	5.21
	25	19.1	2.70	22.8	3.15	26.5	3.33	28.3	4.13	30.7	4.25	34.9	4.88	37.6	5.56
	27	19.1	2.88	22.8	3.38	26.5	3.56	28.3	4.45	30.7	4.51	34.9	5.19	37.6	5.93
	29	19.1	3.08	22.8	3.63	26.5	3.81	28.3	4.58	30.7	4.81	34.9	5.52	37.6	6.32
	31	19.1	3.30	22.8	3.90	26.5	4.07	28.3	4.89	30.7	5.10	34.9	5.87	37.6	6.72
	33	19.1	3.52	22.8	4.18	26.5	4.36	28.3	5.15	30.7	5.41	34.9	6.24	37.6	7.14
35	19.1	3.75	22.8	4.48	26.5	4.65	28.3	5.30	30.7	5.73	34.9	6.63	37.6	7.59	
37	19.1	4.00	22.8	4.79	26.5	4.96	28.3	5.54	30.7	6.08	34.9	7.03	37.6	8.06	
39	19.1	4.25	22.8	5.12	26.5	5.29	28.3	5.76	30.7	6.44	34.9	7.46	37.6	8.56	
41	19.1	4.41	22.8	5.32	26.5	5.48	28.3	5.97	30.7	6.72	34.9	7.85	37.6	8.96	
43	19.1	4.57	22.8	5.42	26.5	5.68	28.3	6.35	30.7	6.89	34.9	8.25	37.6	9.36	
45	19.1	4.78	22.8	6.10	26.5	6.50	28.3	7.02	30.7	7.70	34.9	9.05	37.6	9.75	
48	19.1	5.62	22.8	6.42	26.5	7.21	28.3	8.01	30.7	8.80	34.9	9.60	37.6	10.39	
50	19.1	6.46	22.8	7.25	26.5	8.05	28.3	8.84	30.7	9.64	34.9	10.44	37.6	11.23	
52	19.1	7.30	22.8	8.09	26.5	8.89	28.3	9.68	30.7	10.48	34.9	11.27	37.6	12.07	
54	19.1	8.13	22.8	8.93	26.5	9.73	28.3	10.52	30.7	11.32	34.9	12.11	37.6	12.91	

Обозначения:

CR: Индекс установленной мощности;

ТС: Полная производительность (кВт);

PI: Потребляемая мощность (компрессор + двигатель вентилятора наружного блока) (кВт)

Примечание: 1. В серых ячейках указаны расчётные значения.

MVS FDC II-S

Таблица 2-8.3: Таблица холодопроизводительности для блоков производительностью 22 л.с.

CR	Температура наружного воздуха(°C DB)	Температура в помещении (°C DB/WD)													
		20.8/14		23.3/16		25.8/18		27/19		28.2/20		30.7/22		32/24	
		ТС	PI	ТС	PI	ТС	PI	ТС	PI	ТС	PI	ТС	PI	ТС	PI
		кВт	кВт	кВт	кВт	кВт	кВт	кВт	кВт	кВт	кВт	кВт	кВт	кВт	кВт
130%	-5	55.7	8.34	67.7	9.34	76.4	10.07	78.6	10.93	84.0	11.67	86.4	12.69	87.0	12.77
	-2	55.7	8.34	67.7	9.54	76.4	10.07	79.3	11.00	84.0	11.67	86.4	12.85	87.0	12.90
	0	55.7	8.48	67.7	9.72	76.4	10.47	79.3	11.63	84.0	12.35	86.4	13.01	87.0	13.07
	2	55.7	8.63	67.7	9.74	76.4	10.86	79.3	12.31	84.0	12.49	86.4	13.11	87.0	13.27
	4	55.7	8.82	67.7	9.95	76.4	11.26	79.3	12.36	84.0	12.65	86.4	13.10	87.0	13.52
	6	55.7	8.99	67.7	10.16	76.4	11.71	79.3	12.47	82.6	13.05	83.8	13.10	87.0	13.62
	8	55.7	9.21	67.7	10.41	76.4	12.34	79.3	13.10	81.8	13.47	82.9	13.16	86.1	13.75
	10	55.7	9.40	67.7	10.66	76.4	12.83	79.3	13.55	81.0	13.57	82.7	13.57	85.0	14.15
	12	55.7	9.57	67.7	10.88	76.4	13.10	78.4	13.71	79.9	13.93	82.0	13.81	84.1	14.24
	14	55.7	9.76	67.7	11.10	75.9	13.16	77.8	13.78	78.9	14.05	81.4	14.05	83.0	14.56
	16	55.7	9.92	67.7	11.34	75.0	13.53	76.4	14.05	77.9	14.34	80.8	14.37	82.3	14.79
	18	55.7	10.11	67.7	11.59	73.9	13.73	75.2	14.23	76.9	14.73	80.3	14.87	81.5	15.01
	20	55.7	10.33	67.7	12.39	73.1	14.45	74.0	14.95	75.9	15.45	79.7	15.58	80.7	15.75
	21	55.7	10.61	67.7	12.86	72.8	14.81	74.3	15.31	74.9	15.81	79.1	15.97	80.0	16.11
	23	55.7	11.38	67.7	13.85	71.4	15.52	72.6	16.02	73.9	16.52	78.5	16.68	79.2	16.85
	25	55.7	12.15	67.7	14.89	70.3	16.24	71.6	16.74	72.9	17.26	77.9	17.43	78.4	17.59
	27	55.7	12.97	67.7	15.99	69.4	16.95	70.5	17.82	71.9	17.98	77.4	18.17	77.6	18.36
	29	55.7	13.85	67.7	17.14	68.3	17.67	69.5	18.77	70.9	18.72	76.8	18.91	76.9	19.10
	31	55.7	14.79	65.4	18.19	67.3	18.41	68.6	19.70	69.9	19.43	76.2	19.65	76.1	19.87
	33	55.7	15.75	64.3	18.90	66.3	19.12	67.5	20.78	68.9	20.17	75.6	20.40	75.3	20.62
	35	55.7	16.79	63.2	19.62	65.3	19.86	66.3	20.81	67.9	20.92	75.1	21.17	74.6	21.38
	37	55.7	17.87	62.3	20.50	64.3	20.61	65.5	21.13	66.9	21.69	74.5	21.93	73.8	22.18
	39	55.7	19.02	61.1	21.31	63.2	21.41	64.5	21.87	66.3	22.43	73.9	22.68	73.0	22.95
	41	55.7	20.02	60.5	22.12	62.5	22.22	63.5	22.62	64.5	23.05	73.5	23.29	72.3	23.57
43	55.7	20.81	60.1	22.94	62.2	23.65	62.4	23.98	63.9	24.23	73.5	24.44	71.5	24.67	
45	55.7	21.60	59.7	23.96	61.5	24.66	61.4	25.14	62.9	25.38	73.5	25.54	70.7	26.08	
48	55.7	24.47	59.3	25.10	60.8	25.72	60.4	26.34	62.0	26.97	73.5	27.59	70.0	28.22	
50	55.7	27.34	57.5	27.97	59.6	28.59	59.3	29.22	60.9	29.84	73.5	30.46	69.2	31.09	
52	55.7	30.21	56.6	30.84	58.7	31.46	58.3	32.09	59.9	32.71	73.5	33.34	68.4	33.96	
54	55.7	33.09	55.7	33.71	57.9	34.33	57.3	34.96	58.9	35.58	73.5	36.21	67.6	36.83	
120%	-5	52.1	8.04	60.4	8.71	70.3	10.07	76.5	11.32	80.1	12.06	81.9	13.10	83.7	13.46
	-2	52.1	8.12	60.4	8.81	70.3	10.19	76.5	11.40	80.1	12.22	81.9	13.21	83.7	13.51
	0	52.1	8.20	60.4	8.88	70.3	10.32	76.5	11.43	80.1	12.33	81.9	13.29	83.7	13.54
	2	52.1	8.22	60.4	8.98	70.3	10.40	76.5	11.55	80.1	12.39	81.9	13.40	83.7	13.56
	4	52.1	8.30	60.4	9.11	70.3	10.57	76.5	11.66	80.1	12.57	81.9	13.42	83.7	13.60
	6	52.1	8.39	60.4	9.19	70.3	10.71	76.5	11.81	80.1	12.71	81.9	13.54	83.7	13.65
	8	52.1	8.46	60.4	9.29	70.3	10.88	76.5	11.97	80.1	12.85	81.9	13.58	83.7	13.71
	10	52.1	8.57	60.4	9.43	70.3	10.99	76.5	12.21	80.1	12.86	81.9	13.62	83.7	13.78
	12	52.1	8.73	60.4	9.62	70.3	11.24	76.5	12.46	79.0	12.92	80.8	13.55	82.6	13.87
	14	52.1	8.90	60.4	9.84	70.3	11.48	76.5	12.74	77.9	13.01	79.9	13.76	81.7	14.04
	16	52.1	9.06	60.4	10.06	70.3	11.73	76.3	12.92	77.0	13.21	78.8	14.00	80.6	14.26
	18	52.1	9.22	60.4	10.28	70.3	12.17	74.8	13.31	75.9	13.57	77.6	14.33	79.7	14.47
	20	52.1	9.42	60.4	10.72	70.3	13.21	74.0	14.03	75.0	14.29	76.7	15.04	78.5	15.18
	21	52.1	9.50	60.4	11.13	70.3	13.74	72.7	14.89	74.3	14.64	76.3	15.40	78.1	15.56
	23	52.1	10.16	60.4	12.01	70.3	14.81	71.2	16.08	73.4	15.36	75.2	16.14	77.0	16.28
	25	52.1	10.84	60.4	12.91	69.2	15.52	70.3	16.77	72.3	16.07	74.3	16.85	76.1	17.02
	27	52.1	11.59	60.4	13.87	68.3	16.21	69.2	17.87	71.4	16.81	73.2	17.59	75.0	17.76
	29	52.1	12.35	60.4	14.89	67.2	16.92	68.1	18.62	70.3	17.52	72.0	18.34	74.1	18.50
	31	52.1	13.18	60.4	15.96	66.1	17.66	67.2	19.54	69.4	18.27	71.2	19.08	72.9	19.27
	33	52.1	14.03	60.4	17.09	65.1	18.38	66.1	20.37	68.2	18.98	70.0	19.82	71.8	20.01
	35	52.1	14.93	60.4	18.29	64.1	19.09	64.9	20.64	67.3	19.72	69.1	20.56	70.9	20.78
	37	52.1	15.89	60.4	19.56	63.1	19.83	64.1	20.76	65.6	20.89	68.0	21.30	69.8	21.55
	39	52.1	16.91	60.2	20.71	62.0	20.54	63.0	20.89	64.5	21.20	67.1	22.07	68.9	22.29
	41	52.1	17.84	59.7	20.86	61.5	21.27	62.4	21.87	63.3	21.94	65.3	22.81	67.0	23.05
43	52.1	18.63	59.4	21.02	61.0	21.87	61.9	22.36	62.8	22.69	64.2	23.55	65.9	23.81	
45	52.1	19.41	59.1	21.23	60.5	22.30	61.3	23.14	62.3	23.43	62.9	24.30	65.5	24.56	
48	52.1	22.26	58.7	22.88	59.9	23.50	60.7	24.12	61.8	24.74	61.7	25.36	64.7	25.98	
50	52.1	25.11	58.4	25.73	59.2	26.35	60.0	26.97	60.8	27.59	60.3	28.21	63.3	28.82	
52	52.1	27.96	58.0	28.58	58.6	29.20	59.4	29.82	60.0	30.44	59.1	31.05	62.2	31.67	
54	52.1	30.81	57.7	31.43	58.0	32.05	58.7	32.66	59.3	33.28	57.8	33.90	61.1	34.52	

Обозначения:

CR: Индекс установленной мощности;
 ТС: Полная производительность (кВт);
 PI: Потребляемая мощность (компрессор + двигатель вентилятора наружного блока) (кВт)

Примечание: 1. В серых ячейках указаны расчётные значения.

Продолжение таблицы на следующей странице...

Таблица 2-8.3: Таблица холодопроизводительности для блоков производительностью 22 л.с. (продолжение)

CR	Температура наружного воздуха(°C DB)	Температура в помещении (°C DB/WD)													
		20.8/14		23.3/16		25.8/18		27/19		28.2/20		30.7/22		32/24	
		ТС	PI	ТС	PI	ТС	PI	ТС	PI	ТС	PI	ТС	PI	ТС	PI
		кВт	кВт	кВт	кВт	кВт	кВт	кВт	кВт	кВт	кВт	кВт	кВт	кВт	кВт
110%	-5	48.1	7.03	55.5	7.93	67.2	9.41	69.4	10.59	74.7	11.65	80.3	12.11	82.1	12.91
	-2	48.1	7.16	55.5	8.04	67.2	9.50	69.4	10.70	74.7	11.74	80.3	12.24	82.1	12.98
	0	48.1	7.23	55.5	8.09	67.2	9.58	69.4	10.77	74.7	11.88	80.3	12.36	82.1	13.13
	2	48.1	7.39	55.5	8.18	67.2	9.75	69.4	10.90	74.7	12.01	80.3	12.54	82.1	13.30
	4	48.1	7.54	55.5	8.28	67.2	9.85	69.4	11.04	74.7	12.20	80.3	12.72	82.1	13.42
	6	48.1	7.61	55.5	8.38	67.2	9.96	69.4	11.23	74.7	12.34	80.3	12.86	82.1	13.63
	8	48.1	7.68	55.5	8.53	67.2	10.08	69.4	11.35	74.7	12.48	80.3	12.95	82.1	13.77
	10	48.1	7.77	55.5	8.66	67.2	10.24	69.4	11.55	74.7	12.70	80.3	13.05	82.1	13.89
	12	48.1	7.94	55.5	8.85	67.2	10.46	69.4	11.80	74.7	12.94	79.4	13.24	81.0	14.07
	14	48.1	8.08	55.5	9.02	67.2	10.68	69.4	12.02	74.7	13.19	78.3	13.35	80.1	14.17
	16	48.1	8.22	55.5	9.21	67.2	10.90	69.4	12.27	74.7	13.46	77.4	13.52	79.0	14.32
	18	48.1	8.38	55.5	9.40	67.2	11.14	69.4	12.63	74.7	14.12	76.3	14.23	78.1	14.78
	20	48.1	8.54	55.5	9.62	67.2	11.86	69.4	13.61	73.6	14.84	75.4	14.95	77.0	15.49
	21	48.1	8.63	55.5	9.92	67.2	12.33	69.4	14.68	73.2	15.20	74.7	15.30	76.5	15.85
	23	48.1	9.04	55.5	10.69	67.2	13.29	69.4	15.63	72.1	15.88	73.8	16.04	75.4	16.59
	25	48.1	9.64	55.5	11.49	67.2	14.28	69.4	16.67	71.2	16.59	72.7	16.76	74.5	17.31
	27	48.1	10.28	55.5	12.34	67.2	15.35	68.5	17.48	70.0	17.31	71.8	17.48	73.4	18.05
	29	48.1	10.96	55.5	13.22	67.2	16.47	67.2	18.50	69.1	18.05	70.7	18.22	72.5	18.79
	31	48.1	11.68	55.5	14.15	67.2	17.66	66.0	19.52	68.0	18.77	69.8	18.93	71.4	19.53
	33	48.1	12.42	55.5	15.14	67.2	18.67	65.6	20.27	67.1	19.48	68.7	19.67	70.5	20.28
	35	48.1	13.21	55.5	16.18	63.6	19.39	63.8	20.52	66.0	20.22	67.6	20.41	69.4	21.02
	37	48.1	14.47	55.5	17.28	62.0	20.13	63.1	20.62	64.9	20.94	66.7	21.16	68.2	21.76
	39	48.1	15.70	55.5	18.47	60.9	20.84	61.9	21.36	63.8	21.68	65.6	21.90	67.3	22.53
	41	48.1	16.94	55.5	18.62	59.8	21.00	61.3	21.52	62.7	21.83	63.5	22.15	65.4	22.68
	43	48.1	18.17	55.5	18.87	58.7	21.15	60.7	21.67	61.7	21.99	63.0	22.73	64.4	23.14
	45	48.1	19.20	55.5	19.54	57.6	21.58	59.6	22.12	60.6	22.43	61.3	23.23	62.9	23.91
48	48.1	22.03	55.5	22.65	56.5	23.26	58.8	23.88	59.6	24.50	60.6	25.11	61.6	25.73	
50	48.1	24.86	54.3	25.48	55.3	26.10	57.9	26.71	58.5	27.33	59.2	27.94	60.2	28.56	
52	48.1	27.70	53.0	28.31	54.2	28.93	57.0	29.54	57.4	30.16	58.0	30.78	58.9	31.39	
54	48.1	30.53	51.8	31.14	53.1	31.76	56.1	32.38	56.4	32.99	56.9	33.61	57.5	34.22	
100%	-5	43.1	7.22	50.7	7.86	60.6	8.67	61.5	10.18	66.7	9.94	76.7	11.01	79.0	12.14
	-2	43.1	7.32	50.7	7.96	60.6	8.85	61.5	10.26	66.7	10.08	76.7	11.15	79.0	12.22
	0	43.1	7.40	50.7	8.06	60.6	8.99	61.5	10.41	66.7	10.18	76.7	11.35	79.0	12.36
	2	43.1	7.51	50.7	8.16	60.6	9.20	61.5	10.51	66.7	10.30	76.7	11.53	79.0	12.56
	4	43.1	7.58	50.7	8.31	60.6	9.32	61.5	10.66	66.7	10.44	76.7	11.65	79.0	12.70
	6	43.1	7.74	50.7	8.43	60.6	9.48	61.5	10.89	66.7	10.60	76.7	11.83	79.0	12.90
	8	43.1	7.86	50.7	8.60	60.6	9.65	61.5	11.09	66.7	10.79	76.7	12.04	79.0	13.12
	10	43.1	8.02	50.7	8.76	60.6	9.81	61.5	11.26	66.7	11.00	76.7	12.25	79.0	13.32
	12	43.1	8.18	50.7	8.95	60.6	10.18	61.5	11.48	66.7	11.22	76.7	12.50	77.9	13.42
	14	43.1	8.35	50.7	9.14	60.6	10.65	61.5	12.21	66.7	11.43	76.7	12.77	77.0	13.59
	16	43.1	8.51	50.7	9.36	60.6	10.91	61.5	12.52	66.7	11.68	74.4	12.93	75.9	13.75
	18	43.1	8.67	50.7	9.55	60.6	11.33	61.5	13.01	66.7	11.92	73.5	13.39	75.0	14.11
	20	43.1	8.86	50.7	9.88	60.6	12.27	61.5	13.90	66.7	12.82	72.4	14.07	73.9	14.81
	21	43.1	8.94	50.7	10.28	60.6	13.15	61.5	14.75	66.7	13.28	72.0	14.42	73.5	15.16
	23	43.1	9.57	50.7	11.10	60.6	14.14	61.5	15.76	66.7	14.28	71.1	15.13	72.4	15.87
	25	43.1	10.25	50.7	11.97	60.6	15.26	61.5	16.55	66.7	15.34	70.0	15.84	71.5	16.58
	27	43.1	10.95	50.7	12.86	60.6	16.16	61.5	17.55	66.7	16.46	68.9	16.54	70.4	17.31
	29	43.1	11.71	50.7	13.82	60.6	17.37	61.5	18.07	66.5	17.52	68.0	17.88	69.5	18.02
	31	43.1	12.53	50.7	14.82	60.6	18.58	61.5	18.40	65.6	18.22	66.9	18.53	68.4	18.75
	33	43.1	13.37	50.7	15.88	60.6	19.46	61.5	18.92	64.5	18.93	66.0	19.21	67.6	19.48
	35	43.1	14.24	50.7	17.02	60.6	19.86	61.5	20.16	63.4	20.19	64.9	20.39	66.5	20.60
	37	43.1	15.19	50.7	18.22	60.6	20.00	60.7	21.08	62.8	21.38	64.0	21.65	65.4	21.93
	39	43.1	16.17	50.7	19.47	60.6	20.36	59.9	21.90	61.9	22.27	63.0	22.71	64.5	22.90
	41	43.1	16.78	50.7	20.22	60.6	20.67	59.2	22.68	61.0	23.15	60.6	23.37	63.6	23.61
	43	43.1	17.38	50.7	20.62	60.6	21.35	59.0	23.76	60.2	24.14	61.0	24.55	61.2	24.74
	45	43.1	18.19	50.7	21.19	60.6	22.69	58.6	25.27	59.3	26.66	60.5	28.00	60.3	28.54
48	43.1	20.97	50.7	22.58	60.6	24.19	57.9	27.22	58.5	28.83	59.1	30.44	59.4	32.06	
50	43.1	23.75	50.7	25.36	60.6	26.98	57.4	28.59	57.6	30.20	58.2	31.81	58.5	33.43	
52	43.1	26.53	50.7	28.15	60.6	29.76	56.8	31.37	56.8	32.98	57.3	34.60	57.6	36.21	
54	43.1	29.31	50.7	30.93	60.6	32.54	56.3	34.15	55.9	35.77	56.4	37.38	56.7	38.99	

Обозначения:

CR: Индекс установленной мощности;
 ТС: Полная производительность (кВт);
 PI: Потребляемая мощность (компрессор + двигатель вентилятора наружного блока) (кВт)

Примечание: 1. В серых ячейках указаны расчётные значения.

Продолжение таблицы на следующей странице...

MVS FDC II-S

Таблица 2-8.3: Таблица холодопроизводительности для блоков производительностью 22 л.с. (продолжение)

CR	Температура наружного воздуха (°C DB)	Температура в помещении (°C DB/WD)													
		20.8/14		23.3/16		25.8/18		27/19		28.2/20		30.7/22		32/24	
		ТС	PI	ТС	PI	ТС	PI	ТС	PI	ТС	PI	ТС	PI	ТС	PI
		кВт	кВт	кВт	кВт	кВт	кВт	кВт	кВт	кВт	кВт	кВт	кВт	кВт	кВт
90%	-5	37.5	5.77	44.7	6.29	52.0	6.94	55.5	8.14	60.2	7.95	68.6	8.81	73.6	9.71
	-2	37.5	5.85	44.7	6.37	52.0	7.08	55.5	8.21	60.2	8.06	68.6	8.92	73.6	9.77
	0	37.5	5.92	44.7	6.45	52.0	7.19	55.5	8.33	60.2	8.14	68.6	9.08	73.6	9.89
	2	37.5	6.00	44.7	6.53	52.0	7.36	55.5	8.41	60.2	8.24	68.6	9.23	73.6	10.05
	4	37.5	6.06	44.7	6.64	52.0	7.45	55.5	8.53	60.2	8.35	68.6	9.32	73.6	10.16
	6	37.5	6.19	44.7	6.74	52.0	7.58	55.5	8.71	60.2	8.48	68.6	9.47	73.6	10.32
	8	37.5	6.29	44.7	6.88	52.0	7.72	55.5	8.87	60.2	8.63	68.6	9.63	73.6	10.50
	10	37.5	6.42	44.7	7.01	52.0	7.84	55.5	9.01	60.2	8.80	68.6	9.80	73.6	10.65
	12	37.5	6.55	44.7	7.16	52.0	8.14	55.5	9.19	60.2	8.97	68.6	10.00	73.6	10.74
	14	37.5	6.68	44.7	7.31	52.0	8.52	55.5	9.77	60.2	9.14	68.6	10.21	73.6	10.87
	16	37.5	6.81	44.7	7.49	52.0	8.73	55.5	10.02	60.2	9.34	68.6	10.34	73.6	11.00
	18	37.5	6.94	44.7	7.64	52.0	9.06	55.5	10.41	60.2	9.54	68.6	10.71	73.6	11.28
	20	37.5	7.09	44.7	7.90	52.0	9.82	55.5	11.12	60.2	10.25	68.6	11.26	73.6	11.85
	21	37.5	7.15	44.7	8.23	52.0	10.52	55.5	11.80	60.2	10.62	68.6	11.54	73.6	12.13
	23	37.5	7.65	44.7	8.88	52.0	11.31	55.5	12.61	60.2	11.43	68.6	12.10	73.6	12.70
	25	37.5	8.20	44.7	9.57	52.0	12.21	55.5	13.24	60.2	12.28	68.6	12.67	73.6	13.26
	27	37.5	8.76	44.7	10.29	52.0	12.93	55.5	14.04	60.2	13.17	68.6	13.23	73.6	13.85
	29	37.5	9.37	44.7	11.05	52.0	13.90	55.5	14.45	60.2	14.01	68.6	14.31	73.6	14.41
	31	37.5	10.02	44.7	11.86	52.0	14.86	55.5	14.72	60.2	14.58	68.6	14.82	73.6	15.00
	33	37.5	10.70	44.7	12.70	52.0	15.57	55.5	15.13	60.2	15.14	68.6	15.37	73.6	15.59
	35	37.5	11.39	44.7	13.62	52.0	15.89	55.5	16.13	60.2	16.15	68.6	16.32	73.6	16.48
	37	37.5	12.15	44.7	14.57	52.0	16.00	55.5	16.85	60.2	17.10	68.6	17.32	73.6	17.55
	39	37.5	12.94	44.7	15.57	52.0	16.29	55.5	17.12	60.2	17.81	68.6	18.17	73.6	18.32
	41	37.5	13.42	44.7	16.18	52.0	16.53	55.5	17.44	60.2	18.52	68.6	18.69	73.6	18.89
43	37.5	13.90	44.7	16.50	52.0	17.08	55.5	17.77	60.2	19.31	68.6	19.64	73.6	19.79	
45	37.5	14.55	44.7	16.96	52.0	18.15	55.5	18.09	60.2	19.72	68.6	20.47	73.6	20.90	
48	37.5	16.77	44.7	17.58	52.0	18.39	55.5	19.19	60.2	20.00	68.6	20.81	73.6	21.61	
50	37.5	19.00	44.7	19.81	52.0	20.61	55.5	21.42	60.2	22.23	68.6	23.03	73.6	23.84	
52	37.5	21.23	44.7	22.03	52.0	22.84	55.5	23.65	60.2	24.45	68.6	25.26	73.6	26.06	
54	37.5	23.45	44.7	24.26	52.0	25.06	55.5	25.87	60.2	26.68	68.6	27.48	73.6	28.29	
80%	-5	33.4	4.42	39.8	4.57	46.2	5.31	49.5	4.95	53.8	6.59	61.2	7.58	65.6	8.68
	-2	33.4	4.48	39.8	4.62	46.2	5.38	49.5	4.96	53.8	6.67	61.2	7.65	65.6	8.76
	0	33.4	4.53	39.8	4.68	46.2	5.47	49.5	5.07	53.8	6.76	61.2	7.74	65.6	8.83
	2	33.4	4.59	39.8	4.74	46.2	5.53	49.5	5.29	53.8	6.86	61.2	7.90	65.6	8.96
	4	33.4	4.64	39.8	4.81	46.2	5.63	49.5	5.31	53.8	6.95	61.2	8.02	65.6	9.09
	6	33.4	4.74	39.8	4.91	46.2	5.74	49.5	5.46	53.8	7.07	61.2	8.15	65.6	9.24
	8	33.4	4.81	39.8	5.01	46.2	5.86	49.5	5.66	53.8	7.19	61.2	8.30	65.6	9.33
	10	33.4	4.91	39.8	5.13	46.2	5.98	49.5	5.72	53.8	7.36	61.2	8.40	65.6	9.48
	12	33.4	5.01	39.8	5.22	46.2	6.09	49.5	5.87	53.8	7.50	61.2	8.57	65.6	9.66
	14	33.4	5.11	39.8	5.32	46.2	6.21	49.5	5.99	53.8	7.63	61.2	8.72	65.6	9.83
	16	33.4	5.21	39.8	5.42	46.2	6.35	49.5	6.13	53.8	7.79	61.2	8.90	65.6	10.01
	18	33.4	5.31	39.8	5.54	46.2	6.46	49.5	6.35	53.8	7.94	61.2	9.07	65.6	10.32
	20	33.4	5.43	39.8	5.67	46.2	6.60	49.5	6.91	53.8	8.23	61.2	9.75	65.6	10.80
	21	33.4	5.47	39.8	5.71	46.2	6.72	49.5	7.42	53.8	8.53	61.2	10.10	65.6	11.06
	23	33.4	5.86	39.8	5.94	46.2	7.22	49.5	8.05	53.8	9.15	61.2	10.84	65.6	11.56
	25	33.4	6.27	39.8	6.37	46.2	7.75	49.5	8.66	53.8	9.77	61.2	11.60	65.6	12.07
	27	33.4	6.71	39.8	6.80	46.2	8.29	49.5	9.49	53.8	10.45	61.2	12.42	65.6	12.58
	29	33.4	7.17	39.8	7.27	46.2	8.88	49.5	9.89	53.8	11.17	61.2	12.98	65.6	13.08
	31	33.4	7.67	39.8	7.75	46.2	9.48	49.5	10.57	53.8	11.91	61.2	13.49	65.6	13.61
	33	33.4	8.19	39.8	8.26	46.2	10.14	49.5	11.26	53.8	12.71	61.2	14.02	65.6	14.11
	35	33.4	8.72	39.8	8.80	46.2	10.82	49.5	12.34	53.8	13.55	61.2	14.52	65.6	14.64
	37	33.4	9.30	39.8	9.37	46.2	11.54	49.5	12.90	53.8	14.44	61.2	15.03	65.6	15.14
	39	33.4	9.90	39.8	9.99	46.2	12.30	49.5	13.40	53.8	15.40	61.2	15.55	65.6	15.67
	41	33.4	10.27	39.8	10.46	46.2	12.77	49.5	13.89	53.8	15.47	61.2	15.95	65.6	16.04
43	33.4	10.64	39.8	10.92	46.2	13.23	49.5	14.54	53.8	15.80	61.2	16.16	65.6	16.29	
45	33.4	11.13	39.8	11.47	46.2	13.78	49.5	15.47	53.8	16.24	61.2	16.33	65.6	16.51	
48	33.4	12.84	39.8	13.82	46.2	14.81	49.5	15.80	53.8	16.79	61.2	17.77	65.6	18.76	
50	33.4	14.54	39.8	15.53	46.2	16.51	49.5	17.50	53.8	18.49	61.2	19.48	65.6	20.46	
52	33.4	16.24	39.8	17.23	46.2	18.22	49.5	19.21	53.8	20.19	61.2	21.18	65.6	22.17	
54	33.4	17.95	39.8	18.93	46.2	19.92	49.5	20.91	53.8	21.90	61.2	22.88	65.6	23.87	

Обозначения:

CR: Индекс установленной мощности;
 ТС: Полная производительность (кВт);
 PI: Потребляемая мощность (компрессор + двигатель вентилятора наружного блока) (кВт)

Примечание: 1. В серых ячейках указаны расчётные значения.

Продолжение таблицы на следующей странице...

Таблица 2-8.3: Таблица холодопроизводительности для блоков производительностью 22 л.с. (продолжение)

CR	Температура наружного воздуха (°C DB)	Температура в помещении (°C DB/WD)													
		20.8/14		23.3/16		25.8/18		27/19		28.2/20		30.7/22		32/24	
		ТС	PI	ТС	PI	ТС	PI	ТС	PI	ТС	PI	ТС	PI	ТС	PI
		кВт	кВт	кВт	кВт	кВт	кВт	кВт	кВт	кВт	кВт	кВт	кВт	кВт	кВт
70%	-5	29.2	3.58	35.0	3.70	40.5	4.30	43.4	4.97	47.2	5.34	53.6	6.14	57.6	7.04
	-2	29.2	3.63	35.0	3.74	40.5	4.36	43.4	4.99	47.2	5.41	53.6	6.20	57.6	7.11
	0	29.2	3.67	35.0	3.79	40.5	4.43	43.4	5.02	47.2	5.48	53.6	6.27	57.6	7.16
	2	29.2	3.73	35.0	3.84	40.5	4.48	43.4	5.15	47.2	5.56	53.6	6.40	57.6	7.27
	4	29.2	3.76	35.0	3.90	40.5	4.56	43.4	5.23	47.2	5.63	53.6	6.50	57.6	7.37
	6	29.2	3.84	35.0	3.98	40.5	4.65	43.4	5.33	47.2	5.73	53.6	6.61	57.6	7.50
	8	29.2	3.90	35.0	4.06	40.5	4.75	43.4	5.43	47.2	5.83	53.6	6.73	57.6	7.57
	10	29.2	3.98	35.0	4.16	40.5	4.85	43.4	5.52	47.2	5.97	53.6	6.82	57.6	7.69
	12	29.2	4.06	35.0	4.24	40.5	4.94	43.4	5.62	47.2	6.08	53.6	6.95	57.6	7.83
	14	29.2	4.14	35.0	4.31	40.5	5.03	43.4	5.81	47.2	6.19	53.6	7.07	57.6	7.97
	16	29.2	4.22	35.0	4.39	40.5	5.15	43.4	5.83	47.2	6.31	53.6	7.21	57.6	8.11
	18	29.2	4.30	35.0	4.49	40.5	5.24	43.4	5.84	47.2	6.44	53.6	7.36	57.6	8.37
	20	29.2	4.40	35.0	4.60	40.5	5.35	43.4	6.22	47.2	6.68	53.6	7.91	57.6	8.76
	21	29.2	4.44	35.0	4.63	40.5	5.45	43.4	6.66	47.2	6.91	53.6	8.19	57.6	8.97
	23	29.2	4.75	35.0	4.82	40.5	5.86	43.4	7.03	47.2	7.42	53.6	8.79	57.6	9.38
	25	29.2	5.09	35.0	5.17	40.5	6.28	43.4	7.55	47.2	7.92	53.6	9.41	57.6	9.79
	27	29.2	5.44	35.0	5.51	40.5	6.72	43.4	8.08	47.2	8.48	53.6	10.07	57.6	10.20
	29	29.2	5.82	35.0	5.89	40.5	7.20	43.4	8.46	47.2	9.06	53.6	10.53	57.6	10.61
	31	29.2	6.22	35.0	6.29	40.5	7.69	43.4	9.02	47.2	9.66	53.6	10.94	57.6	11.03
	33	29.2	6.64	35.0	6.70	40.5	8.22	43.4	9.57	47.2	10.31	53.6	11.36	57.6	11.44
	35	29.2	7.07	35.0	7.14	40.5	8.78	43.4	10.01	47.2	10.99	53.6	11.78	57.6	11.87
	37	29.2	7.54	35.0	7.60	40.5	9.36	43.4	10.46	47.2	11.71	53.6	12.19	57.6	12.28
	39	29.2	8.03	35.0	8.10	40.5	9.98	43.4	10.87	47.2	12.49	53.6	12.61	57.6	12.71
	41	29.2	8.33	35.0	8.48	40.5	10.35	43.4	11.26	47.2	12.55	53.6	12.93	57.6	13.01
43	29.2	8.63	35.0	8.85	40.5	10.73	43.4	11.79	47.2	12.81	53.6	13.10	57.6	13.21	
45	29.2	9.03	35.0	9.30	40.5	11.18	43.4	12.54	47.2	13.17	53.6	14.24	57.6	14.85	
48	29.2	10.41	35.0	11.41	40.5	12.41	43.4	13.41	47.2	14.41	53.6	15.41	57.6	16.41	
50	29.2	11.79	35.0	12.79	40.5	13.79	43.4	14.79	47.2	15.79	53.6	16.79	57.6	17.79	
52	29.2	13.17	35.0	14.17	40.5	15.17	43.4	16.17	47.2	17.17	53.6	18.17	57.6	19.18	
54	29.2	14.55	35.0	15.55	40.5	16.55	43.4	17.55	47.2	18.55	53.6	19.56	57.6	20.56	
60%	-5	24.9	2.89	29.8	3.15	34.7	3.47	37.1	4.44	40.3	4.84	45.9	5.38	49.2	6.17
	-2	24.9	2.93	29.8	3.19	34.7	3.52	37.1	4.50	40.3	4.92	45.9	5.46	49.2	6.21
	0	24.9	2.96	29.8	3.23	34.7	3.57	37.1	4.56	40.3	4.99	45.9	5.54	49.2	6.29
	2	24.9	3.00	29.8	3.27	34.7	3.61	37.1	4.65	40.3	5.06	45.9	5.66	49.2	6.37
	4	24.9	3.03	29.8	3.32	34.7	3.68	37.1	4.70	40.3	5.16	45.9	5.74	49.2	6.46
	6	24.9	3.10	29.8	3.37	34.7	3.75	37.1	4.81	40.3	5.27	45.9	5.86	49.2	6.62
	8	24.9	3.15	29.8	3.44	34.7	3.83	37.1	4.90	40.3	5.37	45.9	5.97	49.2	6.72
	10	24.9	3.21	29.8	3.51	34.7	3.91	37.1	5.04	40.3	5.46	45.9	6.08	49.2	6.71
	12	24.9	3.27	29.8	3.58	34.7	3.98	37.1	5.13	40.3	5.57	45.9	6.20	49.2	6.82
	14	24.9	3.34	29.8	3.66	34.7	4.06	37.1	5.22	40.3	5.66	45.9	6.31	49.2	6.93
	16	24.9	3.40	29.8	3.75	34.7	4.15	37.1	5.30	40.3	5.77	45.9	6.42	49.2	7.07
	18	24.9	3.47	29.8	3.82	34.7	4.22	37.1	5.39	40.3	5.88	45.9	6.53	49.2	7.20
	20	24.9	3.55	29.8	3.95	34.7	4.31	37.1	5.50	40.3	5.93	45.9	6.66	49.2	7.33
	21	24.9	3.58	29.8	4.12	34.7	4.39	37.1	5.90	40.3	6.04	45.9	6.73	49.2	7.49
	23	24.9	3.83	29.8	4.44	34.7	4.72	37.1	6.30	40.3	6.42	45.9	7.00	49.2	7.56
	25	24.9	4.10	29.8	4.79	34.7	5.06	37.1	6.65	40.3	6.84	45.9	7.47	49.2	8.05
	27	24.9	4.38	29.8	5.15	34.7	5.42	37.1	6.98	40.3	7.29	45.9	7.96	49.2	8.58
	29	24.9	4.69	29.8	5.53	34.7	5.80	37.1	7.27	40.3	7.76	45.9	8.49	49.2	9.16
	31	24.9	5.01	29.8	5.93	34.7	6.20	37.1	7.68	40.3	8.25	45.9	9.03	49.2	9.78
	33	24.9	5.35	29.8	6.36	34.7	6.63	37.1	8.00	40.3	8.76	45.9	9.61	49.2	10.41
	35	24.9	5.70	29.8	6.81	34.7	7.07	37.1	8.07	40.3	9.29	45.9	10.23	49.2	11.10
	37	24.9	6.08	29.8	7.29	34.7	7.55	37.1	8.44	40.3	9.87	45.9	10.88	49.2	11.81
	39	24.9	6.47	29.8	7.79	34.7	8.04	37.1	8.76	40.3	10.24	45.9	11.54	49.2	12.57
	41	24.9	6.71	29.8	8.09	34.7	8.34	37.1	9.08	40.3	10.59	45.9	12.09	49.2	13.37
43	24.9	6.96	29.8	8.25	34.7	8.65	37.1	9.51	40.3	11.12	45.9	12.60	49.2	13.98	
45	24.9	7.52	29.8	9.29	34.7	9.82	37.1	10.35	40.3	12.02	45.9	13.17	49.2	14.58	
48	24.9	8.63	29.8	9.68	34.7	10.73	37.1	11.78	40.3	12.83	45.9	13.88	49.2	14.93	
50	24.9	9.75	29.8	10.80	34.7	11.84	37.1	12.89	40.3	13.94	45.9	14.99	49.2	16.04	
52	24.9	10.86	29.8	11.91	34.7	12.96	37.1	14.01	40.3	15.06	45.9	16.10	49.2	17.15	
54	24.9	11.97	29.8	13.02	34.7	14.07	37.1	15.12	40.3	16.17	45.9	17.22	49.2	18.27	

Обозначения:

CR: Индекс установленной мощности;

ТС: Полная производительность (кВт);

PI: Потребляемая мощность (компрессор + двигатель вентилятора наружного блока) (кВт)

Примечание: 1. В серых ячейках указаны расчётные значения.

Продолжение таблицы на следующей странице...

MVS FDC II-S

Таблица 2-8.3: Таблица холодопроизводительности для блоков производительностью 22 л.с. (продолжение)

CR	Температура наружного воздуха (°C DB)	Температура в помещении (°CDB/WD)													
		20.8/14		23.3/16		25.8/18		27/19		28.2/20		30.7/22		32/24	
		ТС кВт	PI кВт	ТС кВт	PI кВт	ТС кВт	PI кВт	ТС кВт	PI кВт	ТС кВт	PI кВт	ТС кВт	PI кВт	ТС кВт	PI кВт
50%	-5	21.0	2.39	25.1	2.61	29.1	2.87	31.1	3.94	33.7	4.09	38.3	4.65	41.3	5.01
	-2	21.0	2.43	25.1	2.64	29.1	2.91	31.1	4.04	33.7	4.16	38.3	4.71	41.3	5.08
	0	21.0	2.45	25.1	2.67	29.1	2.96	31.1	4.05	33.7	4.21	38.3	4.79	41.3	5.16
	2	21.0	2.49	25.1	2.71	29.1	2.99	31.1	4.07	33.7	4.28	38.3	4.81	41.3	5.26
	4	21.0	2.51	25.1	2.75	29.1	3.05	31.1	4.08	33.7	4.37	38.3	4.93	41.3	5.40
	6	21.0	2.57	25.1	2.79	29.1	3.11	31.1	4.11	33.7	4.45	38.3	5.01	41.3	5.56
	8	21.0	2.61	25.1	2.85	29.1	3.17	31.1	4.13	33.7	4.51	38.3	5.09	41.3	5.74
	10	21.0	2.66	25.1	2.90	29.1	3.23	31.1	4.09	33.7	4.64	38.3	5.22	41.3	5.82
	12	21.0	2.71	25.1	2.97	29.1	3.30	31.1	4.11	33.7	4.73	38.3	5.31	41.3	5.92
	14	21.0	2.77	25.1	3.03	29.1	3.36	31.1	4.13	33.7	4.80	38.3	5.40	41.3	6.03
	16	21.0	2.82	25.1	3.10	29.1	3.44	31.1	4.14	33.7	4.87	38.3	5.50	41.3	6.12
	18	21.0	2.87	25.1	3.16	29.1	3.50	31.1	4.16	33.7	4.96	38.3	5.59	41.3	6.24
	20	21.0	2.94	25.1	3.27	29.1	3.57	31.1	4.36	33.7	5.06	38.3	5.68	41.3	6.36
	21	21.0	2.96	25.1	3.41	29.1	3.64	31.1	4.58	33.7	5.10	38.3	5.75	41.3	6.43
	23	21.0	3.17	25.1	3.68	29.1	3.91	31.1	4.89	33.7	5.20	38.3	5.85	41.3	6.56
	25	21.0	3.40	25.1	3.97	29.1	4.19	31.1	5.20	33.7	5.36	38.3	6.15	41.3	7.01
	27	21.0	3.63	25.1	4.26	29.1	4.49	31.1	5.61	33.7	5.68	38.3	6.54	41.3	7.47
	29	21.0	3.88	25.1	4.58	29.1	4.80	31.1	5.78	33.7	6.06	38.3	6.96	41.3	7.96
	31	21.0	4.15	25.1	4.91	29.1	5.13	31.1	6.16	33.7	6.43	38.3	7.40	41.3	8.47
	33	21.0	4.43	25.1	5.26	29.1	5.49	31.1	6.49	33.7	6.82	38.3	7.86	41.3	9.00
35	21.0	4.72	25.1	5.64	29.1	5.86	31.1	6.68	33.7	7.22	38.3	8.35	41.3	9.56	
37	21.0	5.03	25.1	6.04	29.1	6.25	31.1	6.99	33.7	7.66	38.3	8.86	41.3	10.16	
39	21.0	5.36	25.1	6.45	29.1	6.66	31.1	7.26	33.7	8.12	38.3	9.40	41.3	10.79	
41	21.0	5.56	25.1	6.70	29.1	6.91	31.1	7.52	33.7	8.47	38.3	9.90	41.3	11.29	
43	21.0	5.76	25.1	6.83	29.1	7.16	31.1	8.01	33.7	8.69	38.3	10.40	41.3	11.79	
45	21.0	6.03	25.1	7.69	29.1	8.20	31.1	8.84	33.7	9.71	38.3	11.40	41.3	12.29	
48	21.0	7.08	25.1	8.08	29.1	9.09	31.1	10.09	33.7	11.09	38.3	12.09	41.3	13.10	
50	21.0	8.14	25.1	9.14	29.1	10.14	31.1	11.14	33.7	12.15	38.3	13.15	41.3	14.15	
52	21.0	9.19	25.1	10.20	29.1	11.20	31.1	12.20	33.7	13.20	38.3	14.20	41.3	15.21	
54	21.0	10.25	25.1	11.25	29.1	12.25	31.1	13.26	33.7	14.26	38.3	15.26	41.3	16.26	

Обозначения:

CR: Индекс установленной мощности;
 ТС: Полная производительность (кВт);
 PI: Потребляемая мощность (компрессор + двигатель вентилятора наружного блока) (кВт)

Примечание: 1. В серых ячейках указаны расчётные значения.

Таблица 2-8.4: Таблица холодопроизводительности для блоков производительностью 24 л.с.

CR	Температура наружного воздуха(°C DB)	Температура в помещении (°C DB/WD)													
		20.8/14		23.3/16		25.8/18		27/19		28.2/20		30.7/22		32/24	
		ТС	PI	ТС	PI	ТС	PI	ТС	PI	ТС	PI	ТС	PI	ТС	PI
		кВт	кВт	кВт	кВт	кВт	кВт	кВт	кВт	кВт	кВт	кВт	кВт	кВт	кВт
130%	-5	60.7	8.93	73.8	10.01	83.2	10.80	85.6	11.72	91.6	12.51	94.1	13.61	94.8	13.69
	-2	60.7	8.93	73.8	10.23	83.2	10.80	86.3	11.79	91.6	12.51	94.1	13.78	94.8	13.83
	0	60.7	9.09	73.8	10.42	83.2	11.23	86.3	12.46	91.6	13.24	94.1	13.95	94.8	14.01
	2	60.7	9.25	73.8	10.44	83.2	11.64	86.3	13.19	91.6	13.39	94.1	14.05	94.8	14.22
	4	60.7	9.46	73.8	10.66	83.2	12.08	86.3	13.25	91.6	13.57	94.1	14.04	94.8	14.49
	6	60.7	9.64	73.8	10.89	83.2	12.55	86.3	13.36	90.0	13.99	91.3	14.04	94.8	14.60
	8	60.7	9.87	73.8	11.16	83.2	13.23	86.3	14.04	89.1	14.44	90.4	14.11	93.8	14.74
	10	60.7	10.08	73.8	11.42	83.2	13.75	86.3	14.52	88.2	14.54	90.1	14.54	92.6	15.17
	12	60.7	10.25	73.8	11.66	83.2	14.04	85.4	14.69	87.0	14.93	89.3	14.81	91.7	15.26
	14	60.7	10.46	73.8	11.89	82.7	14.11	84.7	14.77	85.9	15.06	88.7	15.06	90.5	15.61
	16	60.7	10.64	73.8	12.16	81.7	14.50	83.2	15.06	84.8	15.37	88.1	15.41	89.6	15.85
	18	60.7	10.84	73.8	12.43	80.5	14.72	81.9	15.26	83.7	15.79	87.4	15.94	88.8	16.09
	20	60.7	11.08	73.8	13.28	79.7	15.49	80.7	16.02	82.6	16.56	86.8	16.71	87.9	16.88
	21	60.7	11.37	73.8	13.78	79.3	15.87	80.9	16.41	81.6	16.94	86.2	17.12	87.1	17.27
	23	60.7	12.20	73.8	14.84	77.8	16.64	79.1	17.17	80.5	17.71	85.5	17.88	86.3	18.06
	25	60.7	13.02	73.8	15.96	76.6	17.40	78.0	17.94	79.4	18.50	84.9	18.68	85.4	18.86
	27	60.7	13.91	73.8	17.14	75.6	18.17	76.8	19.10	78.3	19.27	84.3	19.48	84.6	19.68
	29	60.7	14.85	73.8	18.38	74.4	18.94	75.8	20.12	77.2	20.06	83.7	20.27	83.8	20.48
	31	60.7	15.85	71.3	19.50	73.3	19.73	74.8	21.12	76.1	20.83	83.0	21.07	82.9	21.30
	33	60.7	16.88	70.0	20.26	72.2	20.50	73.5	22.27	75.0	21.63	82.4	21.86	82.1	22.10
	35	60.7	18.00	68.8	21.03	71.1	21.29	72.2	22.30	73.9	22.42	81.8	22.69	81.2	22.92
	37	60.7	19.15	67.8	21.97	70.0	22.09	71.4	22.65	72.9	23.25	81.1	23.51	80.4	23.78
	39	60.7	20.39	66.6	22.84	68.8	22.95	70.2	23.45	72.2	24.04	80.5	24.31	79.6	24.60
	41	60.7	21.46	65.9	23.72	68.1	23.82	69.1	24.24	70.3	24.71	72.5	24.96	78.7	25.27
	43	60.7	22.31	65.4	24.59	67.7	25.35	68.0	25.70	69.6	25.97	71.2	26.19	77.9	26.44
	45	60.7	23.15	65.0	25.68	67.0	26.43	66.9	26.95	68.5	27.21	69.2	27.37	77.0	27.95
	48	60.7	26.23	64.6	26.90	66.3	27.57	65.8	28.24	67.5	28.91	67.3	29.58	76.2	30.25
	50	60.7	29.31	62.6	29.98	64.9	30.65	64.6	31.32	66.3	31.99	63.2	32.65	75.4	33.32
52	60.7	32.39	61.7	33.06	64.0	33.73	63.5	34.39	65.2	35.06	60.2	35.73	74.5	36.40	
54	60.7	35.47	60.7	36.13	63.1	36.80	62.4	37.47	64.1	38.14	57.2	38.81	73.7	39.48	
120%	-5	56.7	8.62	65.9	9.33	76.6	10.80	83.3	12.14	87.3	12.93	89.2	14.04	91.2	14.43
	-2	56.7	8.71	65.9	9.44	76.6	10.92	83.3	12.22	87.3	13.10	89.2	14.16	91.2	14.48
	0	56.7	8.79	65.9	9.52	76.6	11.06	83.3	12.25	87.3	13.22	89.2	14.25	91.2	14.51
	2	56.7	8.81	65.9	9.63	76.6	11.15	83.3	12.38	87.3	13.28	89.2	14.36	91.2	14.54
	4	56.7	8.90	65.9	9.76	76.6	11.33	83.3	12.50	87.3	13.47	89.2	14.39	91.2	14.58
	6	56.7	8.99	65.9	9.85	76.6	11.48	83.3	12.66	87.3	13.63	89.2	14.51	91.2	14.63
	8	56.7	9.07	65.9	9.96	76.6	11.66	83.3	12.83	87.3	13.78	89.2	14.56	91.2	14.70
	10	56.7	9.18	65.9	10.10	76.6	11.78	83.3	13.09	87.3	13.79	89.2	14.60	91.2	14.77
	12	56.7	9.36	65.9	10.31	76.6	12.04	83.3	13.36	86.1	13.85	88.0	14.52	89.9	14.86
	14	56.7	9.54	65.9	10.55	76.6	12.31	83.3	13.65	84.8	13.94	87.0	14.75	89.0	15.05
	16	56.7	9.71	65.9	10.78	76.6	12.58	83.2	13.85	83.9	14.16	85.8	15.00	87.8	15.28
	18	56.7	9.89	65.9	11.02	76.6	13.05	81.5	14.27	82.6	14.55	84.6	15.36	86.8	15.51
	20	56.7	10.09	65.9	11.49	76.6	14.16	80.7	15.03	81.7	15.31	83.6	16.13	85.6	16.27
	21	56.7	10.18	65.9	11.93	76.6	14.72	79.2	15.97	80.9	15.70	83.1	16.51	85.1	16.68
	23	56.7	10.89	65.9	12.87	76.6	15.87	77.6	17.24	79.9	16.46	81.9	17.30	83.9	17.45
	25	56.7	11.62	65.9	13.84	75.4	16.64	76.6	17.98	78.7	17.23	80.9	18.07	82.9	18.24
	27	56.7	12.42	65.9	14.87	74.4	17.37	75.4	19.15	77.8	18.02	79.7	18.86	81.7	19.04
	29	56.7	13.24	65.9	15.96	73.2	18.14	74.1	19.96	76.5	18.79	78.5	19.65	80.7	19.83
	31	56.7	14.12	65.9	17.11	72.0	18.93	73.2	20.95	75.6	19.58	77.5	20.45	79.5	20.66
	33	56.7	15.04	65.9	18.32	71.0	19.70	72.0	21.84	74.3	20.35	76.3	21.25	78.2	21.45
	35	56.7	16.01	65.9	19.61	69.8	20.46	70.7	22.13	73.4	21.14	75.3	22.04	77.3	22.27
	37	56.7	17.04	65.9	20.96	68.8	21.26	69.8	22.26	71.4	22.39	74.1	22.83	76.1	23.10
	39	56.7	18.13	65.6	22.20	67.6	22.02	68.6	22.39	70.2	22.73	73.1	23.66	75.1	23.89
	41	56.7	19.13	65.1	23.37	67.0	22.80	68.0	23.44	69.0	23.52	71.2	24.45	73.0	24.71
	43	56.7	19.97	64.7	22.53	66.5	23.44	67.5	23.96	68.5	24.32	69.9	25.25	71.8	25.52
	45	56.7	20.81	64.4	22.75	65.9	23.90	66.8	24.80	67.9	25.11	68.5	26.05	71.3	26.33
	48	56.7	23.86	64.0	24.53	65.3	25.19	66.2	25.85	67.3	26.52	67.2	27.18	70.4	27.84
	50	56.7	26.92	63.6	27.58	64.5	28.24	65.4	28.91	66.2	29.57	65.7	30.23	68.9	30.90
52	56.7	29.97	63.2	30.63	63.9	31.30	64.7	31.96	65.4	32.62	64.3	33.29	67.8	33.95	
54	56.7	33.02	62.8	33.69	63.2	34.35	64.0	35.01	64.6	35.68	62.9	36.34	66.6	37.01	

Обозначения:

CR: Индекс установленной мощности;
 ТС: Полная производительность (кВт);
 PI: Потребляемая мощность (компрессор + двигатель вентилятора наружного блока) (кВт)

Примечание: 1. В серых ячейках указаны расчётные значения.

Продолжение таблицы на следующей странице...

MVS FDC II-S

Таблица 2-8.4: Таблица холодопроизводительности для блоков производительностью 24 л.с. (продолжение)

CR	Температура наружного воздуха (°C DB)	Температура в помещении (°CDB/WD)													
		20.8/14		23.3/16		25.8/18		27/19		28.2/20		30.7/22		32/24	
		ТС	PI	ТС	PI	ТС	PI	ТС	PI	ТС	PI	ТС	PI	ТС	PI
		кВт	кВт	кВт	кВт	кВт	кВт	кВт	кВт	кВт	кВт	кВт	кВт	кВт	кВт
110%	-5	52.4	7.53	60.5	8.50	73.2	10.09	75.6	11.35	81.4	12.48	87.5	12.98	89.5	13.84
	-2	52.4	7.68	60.5	8.62	73.2	10.19	75.6	11.47	81.4	12.59	87.5	13.12	89.5	13.91
	0	52.4	7.75	60.5	8.67	73.2	10.27	75.6	11.55	81.4	12.73	87.5	13.25	89.5	14.08
	2	52.4	7.92	60.5	8.76	73.2	10.45	75.6	11.68	81.4	12.87	87.5	13.45	89.5	14.26
	4	52.4	8.08	60.5	8.87	73.2	10.56	75.6	11.84	81.4	13.07	87.5	13.64	89.5	14.39
	6	52.4	8.16	60.5	8.99	73.2	10.67	75.6	12.03	81.4	13.23	87.5	13.79	89.5	14.61
	8	52.4	8.24	60.5	9.14	73.2	10.81	75.6	12.17	81.4	13.38	87.5	13.88	89.5	14.76
	10	52.4	8.33	60.5	9.28	73.2	10.98	75.6	12.39	81.4	13.61	87.5	13.98	89.5	14.89
	12	52.4	8.51	60.5	9.49	73.2	11.21	75.6	12.65	81.4	13.87	86.5	14.20	88.3	15.08
	14	52.4	8.66	60.5	9.66	73.2	11.45	75.6	12.89	81.4	14.14	85.3	14.31	87.3	15.19
	16	52.4	8.81	60.5	9.87	73.2	11.68	75.6	13.15	81.4	14.43	84.4	14.49	86.1	15.36
	18	52.4	8.98	60.5	10.08	73.2	11.95	75.6	13.53	81.4	15.14	83.1	15.26	85.1	15.84
	20	52.4	9.16	60.5	10.31	73.2	12.71	75.6	14.59	80.2	15.91	82.2	16.02	83.9	16.61
	21	52.4	9.25	60.5	10.63	73.2	13.21	75.6	15.74	79.7	16.29	81.4	16.40	83.4	16.99
	23	52.4	9.69	60.5	11.46	73.2	14.24	75.6	16.75	78.5	17.02	80.5	17.20	82.2	17.79
	25	52.4	10.34	60.5	12.31	73.2	15.30	75.6	17.87	77.5	17.79	79.2	17.97	81.2	18.55
	27	52.4	11.01	60.5	13.23	73.2	16.45	74.6	18.74	76.3	18.56	78.3	18.73	80.0	19.35
	29	52.4	11.75	60.5	14.17	73.2	17.66	73.2	19.83	75.3	19.35	77.0	19.53	79.0	20.14
	31	52.4	12.52	60.5	15.17	73.2	18.93	71.9	20.92	74.1	20.12	76.1	20.29	77.8	20.94
	33	52.4	13.31	60.5	16.23	73.2	20.01	71.5	21.73	73.1	20.88	74.8	21.09	76.8	21.73
	35	52.4	14.17	60.5	17.35	69.3	20.78	69.5	22.00	71.9	21.68	73.6	21.88	75.6	22.53
	37	52.4	15.51	60.5	18.53	67.6	21.58	68.8	22.10	70.7	22.44	72.6	22.68	74.3	23.32
	39	52.4	16.83	60.5	19.79	66.4	22.34	67.5	22.90	69.5	23.24	71.4	23.47	73.4	24.15
	41	52.4	18.15	60.5	19.96	65.2	22.51	66.8	23.07	68.3	23.40	69.1	23.75	71.2	24.31
43	52.4	19.48	60.5	20.23	63.9	22.67	66.1	23.23	67.2	23.57	68.6	24.37	70.1	24.81	
45	52.4	20.58	60.5	20.94	62.7	23.14	64.9	23.71	66.0	24.05	66.8	24.90	68.6	25.63	
48	52.4	23.62	60.5	24.28	61.5	24.94	64.0	25.60	64.9	26.26	66.0	26.92	67.1	27.58	
50	52.4	26.65	59.2	27.31	60.3	27.97	63.1	28.63	63.7	29.29	64.5	29.95	65.6	30.61	
52	52.4	29.69	57.8	30.35	59.1	31.01	62.1	31.67	62.6	32.33	63.2	32.99	64.1	33.65	
54	52.4	32.72	56.4	33.38	57.8	34.04	61.2	34.70	61.4	35.36	61.9	36.02	62.6	36.68	
100%	-5	47.0	7.74	55.2	8.43	66.1	9.29	67.0	10.91	72.6	10.65	83.5	11.80	86.0	13.01
	-2	47.0	7.84	55.2	8.54	66.1	9.48	67.0	11.00	72.6	10.81	83.5	11.95	86.0	13.10
	0	47.0	7.93	55.2	8.64	66.1	9.64	67.0	11.16	72.6	10.91	83.5	12.17	86.0	13.25
	2	47.0	8.05	55.2	8.75	66.1	9.86	67.0	11.26	72.6	11.04	83.5	12.36	86.0	13.46
	4	47.0	8.13	55.2	8.90	66.1	9.99	67.0	11.43	72.6	11.19	83.5	12.49	86.0	13.61
	6	47.0	8.30	55.2	9.03	66.1	10.16	67.0	11.67	72.6	11.37	83.5	12.69	86.0	13.83
	8	47.0	8.43	55.2	9.22	66.1	10.35	67.0	11.88	72.6	11.56	83.5	12.90	86.0	14.07
	10	47.0	8.60	55.2	9.39	66.1	10.51	67.0	12.07	72.6	11.79	83.5	13.13	86.0	14.28
	12	47.0	8.77	55.2	9.59	66.1	10.91	67.0	12.31	72.6	12.02	83.5	13.39	84.8	14.39
	14	47.0	8.95	55.2	9.80	66.1	11.42	67.0	13.09	72.6	12.25	83.5	13.68	83.9	14.57
	16	47.0	9.12	55.2	10.03	66.1	11.70	67.0	13.42	72.6	12.52	81.0	13.86	82.7	14.74
	18	47.0	9.29	55.2	10.24	66.1	12.14	67.0	13.95	72.6	12.78	80.1	14.36	81.7	15.12
	20	47.0	9.50	55.2	10.59	66.1	13.16	67.0	14.90	72.6	13.74	78.9	15.08	80.5	15.88
	21	47.0	9.59	55.2	11.02	66.1	14.09	67.0	15.81	72.6	14.23	78.4	15.46	80.1	16.26
	23	47.0	10.26	55.2	11.90	66.1	15.16	67.0	16.90	72.6	15.31	77.4	16.22	78.9	17.01
	25	47.0	10.98	55.2	12.83	66.1	16.36	67.0	17.74	72.6	16.45	76.2	16.98	77.9	17.77
	27	47.0	11.74	55.2	13.79	66.1	17.32	67.0	18.81	72.6	17.64	75.0	17.73	76.7	18.56
	29	47.0	12.56	55.2	14.81	66.1	18.62	67.0	19.36	72.4	18.78	74.1	19.17	75.8	19.31
	31	47.0	13.43	55.2	15.89	66.1	19.91	67.0	19.72	71.4	19.54	72.9	19.86	74.6	20.10
	33	47.0	14.33	55.2	17.02	66.1	20.86	67.0	20.28	70.3	20.29	71.9	20.59	73.6	20.89
	35	47.0	15.27	55.2	18.25	66.1	21.29	67.0	21.61	69.1	21.64	70.7	21.86	72.4	22.08
	37	47.0	16.29	55.2	19.53	66.1	21.44	66.1	22.59	68.4	22.92	69.8	23.20	71.2	23.51
	39	47.0	17.33	55.2	20.87	66.1	21.83	65.3	23.47	67.4	23.87	68.6	24.34	70.3	24.54
	41	47.0	17.98	55.2	21.68	66.1	22.15	64.5	24.31	66.5	24.81	66.1	25.05	69.3	25.31
43	47.0	18.63	55.2	22.10	66.1	22.89	64.2	25.47	65.6	25.87	66.5	26.31	66.7	26.52	
45	47.0	19.49	55.2	22.72	66.1	24.33	63.8	27.08	64.6	28.58	65.9	30.02	65.6	30.59	
48	47.0	22.48	55.2	24.21	66.1	25.93	63.1	29.18	63.7	30.90	64.4	32.63	64.7	34.36	
50	47.0	25.46	55.2	27.19	66.1	28.92	62.5	30.65	62.8	32.37	63.4	34.10	63.7	35.83	
52	47.0	28.44	55.2	30.17	66.1	31.90	61.9	33.63	61.8	35.36	62.4	37.08	62.7	38.81	
54	47.0	31.42	55.2	33.15	66.1	34.88	61.4	36.61	60.9	38.34	61.4	40.07	61.7	41.80	

Обозначения:

- CR: Индекс установленной мощности;
- ТС: Полная производительность (кВт);
- PI: Потребляемая мощность (компрессор + двигатель вентилятора наружного блока) (кВт)

Примечание: 1. В серых ячейках указаны расчётные значения.

Продолжение таблицы на следующей странице...

Таблица 2-8.4: Таблица холодопроизводительности для блоков производительностью 24 л.с. (продолжение)

CR	Температура наружного воздуха (°C DB)	Температура в помещении (°CDB/WD)													
		20.8/14		23.3/16		25.8/18		27/19		28.2/20		30.7/22		32/24	
		ТС	PI	ТС	PI	ТС	PI	ТС	PI	ТС	PI	ТС	PI	ТС	PI
		кВт	кВт	кВт	кВт	кВт	кВт	кВт	кВт	кВт	кВт	кВт	кВт	кВт	кВт
90%	-5	40.8	6.19	48.7	6.74	56.7	7.44	60.5	8.73	65.6	8.52	74.7	9.44	80.2	10.41
	-2	40.8	6.28	48.7	6.83	56.7	7.59	60.5	8.80	65.6	8.64	74.7	9.56	80.2	10.48
	0	40.8	6.34	48.7	6.92	56.7	7.71	60.5	8.93	65.6	8.73	74.7	9.73	80.2	10.60
	2	40.8	6.44	48.7	7.00	56.7	7.89	60.5	9.01	65.6	8.83	74.7	9.89	80.2	10.77
	4	40.8	6.50	48.7	7.12	56.7	7.99	60.5	9.14	65.6	8.96	74.7	9.99	80.2	10.89
	6	40.8	6.64	48.7	7.23	56.7	8.13	60.5	9.34	65.6	9.09	74.7	10.15	80.2	11.06
	8	40.8	6.74	48.7	7.38	56.7	8.28	60.5	9.51	65.6	9.25	74.7	10.32	80.2	11.25
	10	40.8	6.88	48.7	7.51	56.7	8.41	60.5	9.65	65.6	9.43	74.7	10.51	80.2	11.42
	12	40.8	7.02	48.7	7.68	56.7	8.73	60.5	9.85	65.6	9.62	74.7	10.72	80.2	11.51
	14	40.8	7.16	48.7	7.84	56.7	9.13	60.5	10.47	65.6	9.80	74.7	10.95	80.2	11.66
	16	40.8	7.30	48.7	8.03	56.7	9.36	60.5	10.74	65.6	10.01	74.7	11.09	80.2	11.79
	18	40.8	7.44	48.7	8.19	56.7	9.71	60.5	11.16	65.6	10.22	74.7	11.48	80.2	12.10
	20	40.8	7.60	48.7	8.47	56.7	10.52	60.5	11.92	65.6	10.99	74.7	12.07	80.2	12.70
	21	40.8	7.67	48.7	8.82	56.7	11.27	60.5	12.65	65.6	11.39	74.7	12.37	80.2	13.00
	23	40.8	8.20	48.7	9.52	56.7	12.13	60.5	13.52	65.6	12.25	74.7	12.97	80.2	13.61
	25	40.8	8.79	48.7	10.26	56.7	13.09	60.5	14.20	65.6	13.16	74.7	13.58	80.2	14.22
	27	40.8	9.39	48.7	11.03	56.7	13.86	60.5	15.05	65.6	14.11	74.7	14.19	80.2	14.85
	29	40.8	10.05	48.7	11.85	56.7	14.90	60.5	15.49	65.6	15.02	74.7	15.33	80.2	15.45
	31	40.8	10.74	48.7	12.71	56.7	15.93	60.5	15.78	65.6	15.63	74.7	15.89	80.2	16.08
	33	40.8	11.47	48.7	13.62	56.7	16.69	60.5	16.22	65.6	16.23	74.7	16.47	80.2	16.71
	35	40.8	12.21	48.7	14.60	56.7	17.03	60.5	17.29	65.6	17.32	74.7	17.49	80.2	17.66
	37	40.8	13.03	48.7	15.62	56.7	17.15	60.5	18.06	65.6	18.33	74.7	18.56	80.2	18.81
	39	40.8	13.87	48.7	16.69	56.7	17.46	60.5	18.36	65.6	19.10	74.7	19.47	80.2	19.63
	41	40.8	14.39	48.7	17.34	56.7	17.72	60.5	18.70	65.6	19.85	74.7	20.04	80.2	20.25
	43	40.8	14.90	48.7	17.68	56.7	18.31	60.5	19.05	65.6	20.70	74.7	21.05	80.2	21.21
45	40.8	15.60	48.7	18.17	56.7	19.46	60.5	19.39	65.6	21.14	74.7	21.94	80.2	22.40	
48	40.8	17.98	48.7	18.85	56.7	19.71	60.5	20.57	65.6	21.44	74.7	22.30	80.2	23.17	
50	40.8	20.37	48.7	21.23	56.7	22.10	60.5	22.96	65.6	23.82	74.7	24.69	80.2	25.55	
52	40.8	22.75	48.7	23.62	56.7	24.48	60.5	25.35	65.6	26.21	74.7	27.07	80.2	27.94	
54	40.8	25.14	48.7	26.00	56.7	26.87	60.5	27.73	65.6	28.60	74.7	29.46	80.2	30.32	
80%	-5	36.4	4.74	43.3	4.89	50.3	5.69	53.9	5.31	58.6	7.06	66.7	8.12	71.5	9.30
	-2	36.4	4.80	43.3	4.95	50.3	5.77	53.9	5.32	58.6	7.15	66.7	8.20	71.5	9.39
	0	36.4	4.86	43.3	5.01	50.3	5.86	53.9	5.44	58.6	7.24	66.7	8.29	71.5	9.47
	2	36.4	4.93	43.3	5.08	50.3	5.93	53.9	5.67	58.6	7.36	66.7	8.47	71.5	9.60
	4	36.4	4.97	43.3	5.16	50.3	6.03	53.9	5.69	58.6	7.45	66.7	8.60	71.5	9.74
	6	36.4	5.08	43.3	5.27	50.3	6.15	53.9	5.85	58.6	7.58	66.7	8.73	71.5	9.91
	8	36.4	5.16	43.3	5.37	50.3	6.29	53.9	6.07	58.6	7.71	66.7	8.89	71.5	10.00
	10	36.4	5.26	43.3	5.49	50.3	6.41	53.9	6.14	58.6	7.89	66.7	9.01	71.5	10.16
	12	36.4	5.37	43.3	5.60	50.3	6.53	53.9	6.29	58.6	8.03	66.7	9.18	71.5	10.35
	14	36.4	5.48	43.3	5.70	50.3	6.66	53.9	6.42	58.6	8.18	66.7	9.35	71.5	10.54
	16	36.4	5.58	43.3	5.81	50.3	6.80	53.9	6.57	58.6	8.35	66.7	9.54	71.5	10.73
	18	36.4	5.69	43.3	5.93	50.3	6.93	53.9	6.81	58.6	8.51	66.7	9.72	71.5	11.06
	20	36.4	5.82	43.3	6.08	50.3	7.07	53.9	7.40	58.6	8.83	66.7	10.45	71.5	11.58
	21	36.4	5.87	43.3	6.12	50.3	7.20	53.9	7.96	58.6	9.14	66.7	10.83	71.5	11.85
	23	36.4	6.28	43.3	6.37	50.3	7.74	53.9	8.63	58.6	9.81	66.7	11.62	71.5	12.39
	25	36.4	6.72	43.3	6.83	50.3	8.30	53.9	9.28	58.6	10.48	66.7	12.44	71.5	12.94
	27	36.4	7.19	43.3	7.29	50.3	8.89	53.9	10.17	58.6	11.21	66.7	13.31	71.5	13.48
	29	36.4	7.69	43.3	7.79	50.3	9.51	53.9	10.60	58.6	11.98	66.7	13.92	71.5	14.02
	31	36.4	8.22	43.3	8.31	50.3	10.16	53.9	11.33	58.6	12.77	66.7	14.46	71.5	14.59
	33	36.4	8.78	43.3	8.85	50.3	10.87	53.9	12.07	58.6	13.63	66.7	15.02	71.5	15.13
	35	36.4	9.35	43.3	9.44	50.3	11.60	53.9	13.23	58.6	14.52	66.7	15.57	71.5	15.69
	37	36.4	9.97	43.3	10.04	50.3	12.37	53.9	13.83	58.6	15.48	66.7	16.11	71.5	16.23
	39	36.4	10.61	43.3	10.71	50.3	13.19	53.9	14.37	58.6	16.51	66.7	16.67	71.5	16.80
	41	36.4	11.01	43.3	11.21	50.3	13.68	53.9	14.88	58.6	16.58	66.7	17.10	71.5	17.19
	43	36.4	11.41	43.3	11.70	50.3	14.18	53.9	15.59	58.6	16.94	66.7	17.32	71.5	17.46
45	36.4	11.93	43.3	12.30	50.3	14.77	53.9	16.58	58.6	17.41	66.7	17.50	71.5	17.69	
48	36.4	13.76	43.3	14.82	50.3	15.88	53.9	16.94	58.6	17.99	66.7	19.05	71.5	20.11	
50	36.4	15.59	43.3	16.64	50.3	17.70	53.9	18.76	58.6	19.82	66.7	20.88	71.5	21.94	
52	36.4	17.41	43.3	18.47	50.3	19.53	53.9	20.59	58.6	21.65	66.7	22.70	71.5	23.76	
54	36.4	19.24	43.3	20.30	50.3	21.35	53.9	22.41	58.6	23.47	66.7	24.53	71.5	25.59	

Обозначения:

CR: Индекс установленной мощности;

ТС: Полная производительность (кВт);

PI: Потребляемая мощность (компрессор + двигатель вентилятора наружного блока) (кВт)

Примечание: 1. В серых ячейках указаны расчётные значения.

Продолжение таблицы на следующей странице...

MVS FDC II-S

Таблица 2-8.4: Таблица холодопроизводительности для блоков производительностью 24 л.с. (продолжение)

CR	Температура наружного воздуха (°C DB)	Температура в помещении (°C DB/WD)													
		20.8/14		23.3/16		25.8/18		27/19		28.2/20		30.7/22		32/24	
		ТС	PI	ТС	PI	ТС	PI	ТС	PI	ТС	PI	ТС	PI	ТС	PI
		кВт	кВт	кВт	кВт	кВт	кВт	кВт	кВт	кВт	кВт	кВт	кВт	кВт	кВт
70%	-5	31.9	3.84	38.1	3.97	44.2	4.61	47.3	5.32	51.4	5.73	58.4	6.59	62.7	7.54
	-2	31.9	3.89	38.1	4.01	44.2	4.68	47.3	5.35	51.4	5.80	58.4	6.65	62.7	7.62
	0	31.9	3.94	38.1	4.07	44.2	4.75	47.3	5.38	51.4	5.87	58.4	6.73	62.7	7.68
	2	31.9	3.99	38.1	4.12	44.2	4.81	47.3	5.53	51.4	5.96	58.4	6.87	62.7	7.79
	4	31.9	4.03	38.1	4.18	44.2	4.89	47.3	5.61	51.4	6.04	58.4	6.97	62.7	7.90
	6	31.9	4.12	38.1	4.27	44.2	4.99	47.3	5.72	51.4	6.15	58.4	7.08	62.7	8.03
	8	31.9	4.18	38.1	4.36	44.2	5.10	47.3	5.82	51.4	6.25	58.4	7.21	62.7	8.11
	10	31.9	4.27	38.1	4.46	44.2	5.19	47.3	5.92	51.4	6.40	58.4	7.31	62.7	8.24
	12	31.9	4.35	38.1	4.54	44.2	5.30	47.3	6.03	51.4	6.51	58.4	7.44	62.7	8.39
	14	31.9	4.44	38.1	4.62	44.2	5.40	47.3	6.22	51.4	6.63	58.4	7.58	62.7	8.54
	16	31.9	4.53	38.1	4.71	44.2	5.52	47.3	6.25	51.4	6.77	58.4	7.73	62.7	8.70
	18	31.9	4.61	38.1	4.81	44.2	5.62	47.3	6.26	51.4	6.90	58.4	7.88	62.7	8.97
	20	31.9	4.72	38.1	4.93	44.2	5.74	47.3	6.67	51.4	7.16	58.4	8.48	62.7	9.39
	21	31.9	4.76	38.1	4.96	44.2	5.84	47.3	7.14	51.4	7.41	58.4	8.78	62.7	9.61
	23	31.9	5.09	38.1	5.17	44.2	6.28	47.3	7.53	51.4	7.95	58.4	9.42	62.7	10.05
	25	31.9	5.45	38.1	5.54	44.2	6.73	47.3	8.09	51.4	8.49	58.4	10.08	62.7	10.49
	27	31.9	5.83	38.1	5.91	44.2	7.21	47.3	8.67	51.4	9.09	58.4	10.79	62.7	10.93
	29	31.9	6.23	38.1	6.32	44.2	7.72	47.3	9.07	51.4	9.71	58.4	11.29	62.7	11.37
	31	31.9	6.67	38.1	6.74	44.2	8.24	47.3	9.67	51.4	10.35	58.4	11.73	62.7	11.83
	33	31.9	7.12	38.1	7.18	44.2	8.81	47.3	10.26	51.4	11.05	58.4	12.18	62.7	12.27
	35	31.9	7.58	38.1	7.65	44.2	9.41	47.3	10.73	51.4	11.78	58.4	12.62	62.7	12.72
	37	31.9	8.08	38.1	8.14	44.2	10.03	47.3	11.22	51.4	12.55	58.4	13.06	62.7	13.16
	39	31.9	8.60	38.1	8.69	44.2	10.69	47.3	11.65	51.4	13.39	58.4	13.52	62.7	13.62
	41	31.9	8.93	38.1	9.09	44.2	11.10	47.3	12.07	51.4	13.45	58.4	13.86	62.7	13.94
43	31.9	9.25	38.1	9.49	44.2	11.50	47.3	12.64	51.4	13.73	58.4	14.04	62.7	14.16	
45	31.9	9.68	38.1	9.97	44.2	11.98	47.3	13.44	51.4	14.12	58.4	15.26	62.7	15.92	
48	31.9	11.16	38.1	12.23	44.2	13.30	47.3	14.38	51.4	15.45	58.4	16.52	62.7	17.59	
50	31.9	12.64	38.1	13.71	44.2	14.78	47.3	15.86	51.4	16.93	58.4	18.00	62.7	19.07	
52	31.9	14.12	38.1	15.19	44.2	16.26	47.3	17.34	51.4	18.41	58.4	19.48	62.7	20.55	
54	31.9	15.60	38.1	16.67	44.2	17.74	47.3	18.82	51.4	19.89	58.4	20.96	62.7	22.03	
60%	-5	27.2	3.10	32.5	3.37	37.8	3.72	40.4	4.76	43.9	5.19	50.0	5.77	53.6	6.62
	-2	27.2	3.14	32.5	3.42	37.8	3.77	40.4	4.83	43.9	5.28	50.0	5.85	53.6	6.66
	0	27.2	3.17	32.5	3.46	37.8	3.83	40.4	4.89	43.9	5.35	50.0	5.94	53.6	6.75
	2	27.2	3.22	32.5	3.50	37.8	3.87	40.4	4.98	43.9	5.43	50.0	6.06	53.6	6.83
	4	27.2	3.25	32.5	3.56	37.8	3.94	40.4	5.04	43.9	5.53	50.0	6.16	53.6	6.93
	6	27.2	3.32	32.5	3.61	37.8	4.02	40.4	5.15	43.9	5.65	50.0	6.28	53.6	7.09
	8	27.2	3.37	32.5	3.69	37.8	4.11	40.4	5.25	43.9	5.76	50.0	6.40	53.6	7.20
	10	27.2	3.44	32.5	3.76	37.8	4.19	40.4	5.40	43.9	5.85	50.0	6.52	53.6	7.19
	12	27.2	3.51	32.5	3.84	37.8	4.27	40.4	5.50	43.9	5.97	50.0	6.64	53.6	7.31
	14	27.2	3.58	32.5	3.92	37.8	4.35	40.4	5.59	43.9	6.07	50.0	6.76	53.6	7.43
	16	27.2	3.65	32.5	4.02	37.8	4.45	40.4	5.69	43.9	6.19	50.0	6.88	53.6	7.57
	18	27.2	3.72	32.5	4.10	37.8	4.53	40.4	5.78	43.9	6.31	50.0	7.00	53.6	7.72
	20	27.2	3.80	32.5	4.24	37.8	4.62	40.4	5.90	43.9	6.35	50.0	7.14	53.6	7.86
	21	27.2	3.84	32.5	4.41	37.8	4.71	40.4	6.33	43.9	6.47	50.0	7.22	53.6	8.03
	23	27.2	4.10	32.5	4.76	37.8	5.06	40.4	6.76	43.9	6.88	50.0	7.50	53.6	8.10
	25	27.2	4.40	32.5	5.13	37.8	5.43	40.4	7.13	43.9	7.33	50.0	8.00	53.6	8.62
	27	27.2	4.70	32.5	5.52	37.8	5.81	40.4	7.48	43.9	7.81	50.0	8.53	53.6	9.20
	29	27.2	5.03	32.5	5.93	37.8	6.22	40.4	7.80	43.9	8.31	50.0	9.10	53.6	9.82
	31	27.2	5.37	32.5	6.36	37.8	6.64	40.4	8.23	43.9	8.84	50.0	9.68	53.6	10.49
	33	27.2	5.74	32.5	6.81	37.8	7.11	40.4	8.58	43.9	9.39	50.0	10.30	53.6	11.16
	35	27.2	6.11	32.5	7.30	37.8	7.58	40.4	8.65	43.9	9.96	50.0	10.97	53.6	11.90
	37	27.2	6.52	32.5	7.81	37.8	8.09	40.4	9.04	43.9	10.58	50.0	11.66	53.6	12.66
	39	27.2	6.94	32.5	8.35	37.8	8.62	40.4	9.39	43.9	10.97	50.0	12.37	53.6	13.47
	41	27.2	7.20	32.5	8.68	37.8	8.94	40.4	9.73	43.9	11.36	50.0	12.96	53.6	14.33
43	27.2	7.46	32.5	8.85	37.8	9.27	40.4	10.19	43.9	11.92	50.0	13.51	53.6	14.98	
45	27.2	8.06	32.5	9.96	37.8	10.52	40.4	11.10	43.9	12.88	50.0	14.11	53.6	15.63	
48	27.2	9.25	32.5	10.38	37.8	11.50	40.4	12.63	43.9	13.75	50.0	14.88	53.6	16.00	
50	27.2	10.45	32.5	11.57	37.8	12.70	40.4	13.82	43.9	14.95	50.0	16.07	53.6	17.19	
52	27.2	11.64	32.5	12.77	37.8	13.89	40.4	15.01	43.9	16.14	50.0	17.26	53.6	18.39	
54	27.2	12.83	32.5	13.96	37.8	15.08	40.4	16.21	43.9	17.33	50.0	18.46	53.6	19.58	

Обозначения:

CR: Индекс установленной мощности;
 ТС: Полная производительность (кВт);
 PI: Потребляемая мощность (компрессор + двигатель вентилятора наружного блока) (кВт)

Примечание: 1. В серых ячейках указаны расчётные значения.

Продолжение таблицы на следующей странице...

Таблица 2-8.4: Таблица холодопроизводительности для блоков производительностью 24 л.с. (продолжение)

CR	Температура наружного воздуха (°C DB)	Температура в помещении (°C DB/WD)													
		20.8/14		23.3/16		25.8/18		27/19		28.2/20		30.7/22		32/24	
		ТС	PI	ТС	PI	ТС	PI	ТС	PI	ТС	PI	ТС	PI	ТС	PI
50%	-5	22.8	2.56	27.3	2.79	31.7	3.08	33.8	4.22	36.7	4.38	41.7	4.98	45.0	5.37
	-2	22.8	2.60	27.3	2.83	31.7	3.12	33.8	4.33	36.7	4.46	41.7	5.05	45.0	5.44
	0	22.8	2.63	27.3	2.86	31.7	3.17	33.8	4.34	36.7	4.51	41.7	5.13	45.0	5.54
	2	22.8	2.67	27.3	2.90	31.7	3.21	33.8	4.36	36.7	4.59	41.7	5.16	45.0	5.64
	4	22.8	2.69	27.3	2.95	31.7	3.27	33.8	4.37	36.7	4.68	41.7	5.29	45.0	5.79
	6	22.8	2.75	27.3	2.99	31.7	3.33	33.8	4.41	36.7	4.77	41.7	5.37	45.0	5.96
	8	22.8	2.79	27.3	3.06	31.7	3.40	33.8	4.42	36.7	4.83	41.7	5.45	45.0	6.15
	10	22.8	2.85	27.3	3.11	31.7	3.47	33.8	4.38	36.7	4.97	41.7	5.60	45.0	6.24
	12	22.8	2.91	27.3	3.18	31.7	3.54	33.8	4.41	36.7	5.07	41.7	5.69	45.0	6.34
	14	22.8	2.96	27.3	3.25	31.7	3.60	33.8	4.43	36.7	5.15	41.7	5.79	45.0	6.47
	16	22.8	3.02	27.3	3.33	31.7	3.68	33.8	4.44	36.7	5.22	41.7	5.89	45.0	6.56
	18	22.8	3.08	27.3	3.39	31.7	3.75	33.8	4.46	36.7	5.32	41.7	5.99	45.0	6.69
	20	22.8	3.15	27.3	3.51	31.7	3.83	33.8	4.67	36.7	5.42	41.7	6.09	45.0	6.81
	21	22.8	3.18	27.3	3.65	31.7	3.90	33.8	4.91	36.7	5.47	41.7	6.17	45.0	6.89
	23	22.8	3.40	27.3	3.94	31.7	4.19	33.8	5.24	36.7	5.57	41.7	6.27	45.0	7.04
	25	22.8	3.64	27.3	4.25	31.7	4.50	33.8	5.57	36.7	5.74	41.7	6.59	45.0	7.51
	27	22.8	3.89	27.3	4.57	31.7	4.81	33.8	6.01	36.7	6.09	41.7	7.01	45.0	8.01
	29	22.8	4.16	27.3	4.91	31.7	5.15	33.8	6.19	36.7	6.49	41.7	7.46	45.0	8.53
	31	22.8	4.45	27.3	5.26	31.7	5.50	33.8	6.60	36.7	6.89	41.7	7.93	45.0	9.08
	33	22.8	4.75	27.3	5.64	31.7	5.88	33.8	6.96	36.7	7.31	41.7	8.43	45.0	9.65
35	22.8	5.06	27.3	6.05	31.7	6.28	33.8	7.16	36.7	7.73	41.7	8.95	45.0	10.25	
37	22.8	5.40	27.3	6.47	31.7	6.70	33.8	7.49	36.7	8.21	41.7	9.50	45.0	10.89	
39	22.8	5.74	27.3	6.92	31.7	7.14	33.8	7.78	36.7	8.70	41.7	10.07	45.0	11.56	
41	22.8	5.96	27.3	7.18	31.7	7.41	33.8	8.06	36.7	9.08	41.7	10.61	45.0	12.10	
43	22.8	6.17	27.3	7.32	31.7	7.68	33.8	8.58	36.7	9.31	41.7	11.15	45.0	12.64	
45	22.8	6.46	27.3	8.25	31.7	8.79	33.8	9.48	36.7	10.41	41.7	12.22	45.0	13.17	
48	22.8	7.59	27.3	8.67	31.7	9.74	33.8	10.81	36.7	11.89	41.7	12.96	45.0	14.04	
50	22.8	8.72	27.3	9.80	31.7	10.87	33.8	11.95	36.7	13.02	41.7	14.09	45.0	15.17	
52	22.8	9.86	27.3	10.93	31.7	12.00	33.8	13.08	36.7	14.15	41.7	15.23	45.0	16.30	
54	22.8	10.99	27.3	12.06	31.7	13.14	33.8	14.21	36.7	15.28	41.7	16.36	45.0	17.43	

Обозначения:

CR: Индекс установленной мощности;

ТС: Полная производительность (кВт);

PI: Потребляемая мощность (компрессор + двигатель вентилятора наружного блока) (кВт)

Примечание: 1. В серых ячейках указаны расчётные значения.

MVS FDC II-S

Таблица 2-8.5: Таблица холодопроизводительности для блоков производительностью 26 л.с.

CR	Температура наружного воздуха (°C DB)	Температура в помещении (°C DB/WD)													
		20.8/14		23.3/16		25.8/18		27/19		28.2/20		30.7/22		32/24	
		ТС кВт	PI кВт	ТС кВт	PI кВт	ТС кВт	PI кВт	ТС кВт	PI кВт	ТС кВт	PI кВт	ТС кВт	PI кВт	ТС кВт	PI кВт
130%	-5	66.1	8.88	80.4	9.95	90.7	10.73	93.3	11.64	99.8	12.43	102.5	13.52	103.3	13.60
	-2	66.1	8.88	80.4	10.16	90.7	10.73	94.1	11.72	99.8	12.43	102.5	13.69	103.3	13.74
	0	66.1	9.03	80.4	10.35	90.7	11.15	94.1	12.38	99.8	13.15	102.5	13.86	103.3	13.92
	2	66.1	9.19	80.4	10.37	90.7	11.57	94.1	13.10	99.8	13.30	102.5	13.96	103.3	14.13
	4	66.1	9.40	80.4	10.59	90.7	12.00	94.1	13.16	99.8	13.48	102.5	13.95	103.3	14.40
	6	66.1	9.58	80.4	10.82	90.7	12.47	94.1	13.28	98.0	13.90	99.5	13.95	103.3	14.50
	8	66.1	9.81	80.4	11.09	90.7	13.14	94.1	13.95	97.1	14.35	98.4	14.02	102.2	14.65
	10	66.1	10.01	80.4	11.35	90.7	13.66	94.1	14.43	96.1	14.45	98.1	14.45	100.9	15.07
	12	66.1	10.19	80.4	11.58	90.7	13.95	93.1	14.60	94.8	14.83	97.3	14.71	99.9	15.16
	14	66.1	10.39	80.4	11.82	90.1	14.02	92.3	14.67	93.6	14.97	96.6	14.96	98.6	15.51
	16	66.1	10.57	80.4	12.08	89.1	14.41	90.7	14.96	92.4	15.27	96.0	15.31	97.6	15.75
	18	66.1	10.77	80.4	12.34	87.7	14.63	89.2	15.16	91.2	15.69	95.3	15.84	96.7	15.98
	20	66.1	11.01	80.4	13.19	86.8	15.39	87.9	15.92	90.1	16.45	94.6	16.60	95.8	16.77
	21	66.1	11.30	80.4	13.69	86.4	15.77	88.1	16.30	88.9	16.83	93.9	17.01	94.9	17.15
	23	66.1	12.12	80.4	14.74	84.8	16.53	86.2	17.06	87.7	17.59	93.2	17.77	94.0	17.94
	25	66.1	12.94	80.4	15.86	83.5	17.29	84.9	17.82	86.5	18.38	92.5	18.56	93.1	18.73
	27	66.1	13.82	80.4	17.03	82.4	18.05	83.7	18.97	85.3	19.14	91.8	19.35	92.2	19.55
	29	66.1	14.75	80.4	18.26	81.1	18.81	82.5	19.99	84.1	19.93	91.1	20.14	91.3	20.34
	31	66.1	15.75	77.6	19.37	79.9	19.60	81.5	20.98	82.9	20.69	90.5	20.93	90.3	21.16
	33	66.1	16.77	76.3	20.13	78.7	20.36	80.1	22.13	81.8	21.49	89.8	21.72	89.4	21.96
	35	66.1	17.88	75.0	20.89	77.5	21.16	78.7	22.16	80.6	22.28	89.1	22.54	88.5	22.77
	37	66.1	19.03	73.9	21.83	76.3	21.95	77.8	22.51	79.4	23.10	88.4	23.36	87.6	23.62
	39	66.1	20.26	72.6	22.70	75.0	22.80	76.5	23.30	78.7	23.89	87.7	24.15	86.7	24.44
	41	66.1	21.32	71.8	23.56	74.2	23.66	75.3	24.08	76.6	24.55	79.0	24.80	85.8	25.11
	43	66.1	22.16	71.3	24.43	73.8	25.18	74.1	25.54	75.8	25.81	77.5	26.02	84.9	26.27
	45	66.1	23.00	70.9	25.52	73.0	26.26	72.9	26.77	74.7	27.03	75.4	27.20	83.9	27.77
	48	66.1	26.06	70.4	26.73	72.2	27.39	71.7	28.06	73.6	28.72	73.3	29.39	83.0	30.05
	50	66.1	29.12	68.3	29.78	70.7	30.45	70.4	31.11	72.3	31.78	68.9	32.44	82.1	33.11
52	66.1	32.18	67.2	32.84	69.7	33.51	69.2	34.17	71.1	34.84	65.6	35.50	81.2	36.17	
54	66.1	35.24	66.2	35.90	68.7	36.56	68.0	37.23	69.9	37.89	62.4	38.56	80.3	39.22	
120%	-5	61.8	8.57	71.7	9.27	83.4	10.73	90.8	12.06	95.1	12.85	97.2	13.95	99.3	14.33
	-2	61.8	8.65	71.7	9.38	83.4	10.85	90.8	12.14	95.1	13.01	97.2	14.07	99.3	14.38
	0	61.8	8.73	71.7	9.45	83.4	10.99	90.8	12.17	95.1	13.14	97.2	14.16	99.3	14.42
	2	61.8	8.75	71.7	9.56	83.4	11.08	90.8	12.30	95.1	13.19	97.2	14.27	99.3	14.44
	4	61.8	8.84	71.7	9.70	83.4	11.26	90.8	12.42	95.1	13.38	97.2	14.30	99.3	14.49
	6	61.8	8.93	71.7	9.78	83.4	11.41	90.8	12.58	95.1	13.54	97.2	14.42	99.3	14.53
	8	61.8	9.01	71.7	9.89	83.4	11.59	90.8	12.75	95.1	13.69	97.2	14.47	99.3	14.60
	10	61.8	9.12	71.7	10.04	83.4	11.70	90.8	13.01	95.1	13.70	97.2	14.51	99.3	14.67
	12	61.8	9.30	71.7	10.25	83.4	11.97	90.8	13.27	93.8	13.76	95.9	14.43	98.0	14.77
	14	61.8	9.47	71.7	10.48	83.4	12.23	90.8	13.56	92.4	13.85	94.8	14.65	96.9	14.95
	16	61.8	9.65	71.7	10.71	83.4	12.49	90.6	13.76	91.4	14.07	93.5	14.91	95.6	15.18
	18	61.8	9.82	71.7	10.95	83.4	12.96	88.8	14.18	90.0	14.45	92.2	15.26	94.6	15.41
	20	61.8	10.03	71.7	11.41	83.4	14.07	87.9	14.94	89.0	15.21	91.1	16.02	93.2	16.17
	21	61.8	10.12	71.7	11.85	83.4	14.63	86.3	15.86	88.2	15.59	90.6	16.40	92.7	16.57
	23	61.8	10.82	71.7	12.79	83.4	15.77	84.5	17.12	87.1	16.35	89.2	17.19	91.4	17.34
	25	61.8	11.55	71.7	13.75	82.1	16.53	83.5	17.86	85.8	17.12	88.2	17.95	90.3	18.12
	27	61.8	12.34	71.7	14.78	81.1	17.26	82.2	19.03	84.7	17.90	86.8	18.74	89.0	18.91
	29	61.8	13.16	71.7	15.86	79.7	18.02	80.8	19.83	83.4	18.66	85.5	19.53	87.9	19.70
	31	61.8	14.03	71.7	17.00	78.5	18.81	79.7	20.81	82.3	19.45	84.5	20.32	86.6	20.52
	33	61.8	14.94	71.7	18.20	77.3	19.57	78.5	21.70	81.0	20.21	83.1	21.11	85.3	21.31
	35	61.8	15.90	71.7	19.48	76.1	20.33	77.1	21.99	79.9	21.00	82.1	21.90	84.2	22.13
	37	61.8	16.93	71.7	20.83	74.9	21.12	76.1	22.11	77.8	22.25	80.7	22.69	82.9	22.95
	39	61.8	18.01	71.5	22.06	73.6	21.88	74.8	22.24	76.5	22.58	79.7	23.50	81.8	23.74
	41	61.8	19.00	70.9	22.22	73.0	22.65	74.1	23.29	75.2	23.37	77.6	24.29	79.5	24.55
	43	61.8	19.84	70.5	22.39	72.5	23.29	73.5	23.81	74.6	24.16	76.2	25.08	78.3	25.35
	45	61.8	20.67	70.1	22.61	71.8	23.75	72.8	24.64	73.9	24.95	74.7	25.88	77.7	26.16
	48	61.8	23.71	69.7	24.37	71.1	25.03	72.1	25.69	73.3	26.34	73.2	27.00	76.8	27.66
	50	61.8	26.74	69.3	27.40	70.3	28.06	71.2	28.72	72.1	29.38	71.6	30.04	75.1	30.70
52	61.8	29.77	68.9	30.43	69.6	31.09	70.5	31.75	71.3	32.41	70.1	33.07	73.8	33.73	
54	61.8	32.81	68.5	33.47	68.9	34.13	69.7	34.79	70.4	35.45	68.6	36.11	72.6	36.77	

Обозначения:

- CR: Индекс установленной мощности;
- ТС: Полная производительность (кВт);
- PI: Потребляемая мощность (компрессор + двигатель вентилятора наружного блока) (кВт)

Примечание: 1. В серых ячейках указаны расчётные значения.

Продолжение таблицы на следующей странице...

Таблица 2-8.5: Таблица холодопроизводительности для блоков производительностью 26 л.с. (продолжение)

CR	Температура наружного воздуха (°C DB)	Температура в помещении (°C DB/WD)													
		20.8/14		23.3/16		25.8/18		27/19		28.2/20		30.7/22		32/24	
		ТС	PI	ТС	PI	ТС	PI	ТС	PI	ТС	PI	ТС	PI	ТС	PI
		кВт	кВт	кВт	кВт	кВт	кВт	кВт	кВт	кВт	кВт	кВт	кВт	кВт	кВт
110%	-5	57.1	7.48	65.9	8.44	79.8	10.03	82.3	11.28	88.7	12.40	95.4	12.90	97.5	13.75
	-2	57.1	7.63	65.9	8.56	79.8	10.12	82.3	11.40	88.7	12.50	95.4	13.03	97.5	13.82
	0	57.1	7.70	65.9	8.62	79.8	10.20	82.3	11.47	88.7	12.65	95.4	13.16	97.5	13.99
	2	57.1	7.87	65.9	8.71	79.8	10.38	82.3	11.61	88.7	12.79	95.4	13.36	97.5	14.16
	4	57.1	8.03	65.9	8.82	79.8	10.49	82.3	11.76	88.7	12.99	95.4	13.55	97.5	14.29
	6	57.1	8.11	65.9	8.93	79.8	10.60	82.3	11.96	88.7	13.14	95.4	13.70	97.5	14.51
	8	57.1	8.18	65.9	9.08	79.8	10.74	82.3	12.09	88.7	13.30	95.4	13.79	97.5	14.67
	10	57.1	8.28	65.9	9.22	79.8	10.90	82.3	12.31	88.7	13.52	95.4	13.89	97.5	14.79
	12	57.1	8.46	65.9	9.42	79.8	11.14	82.3	12.57	88.7	13.78	94.3	14.10	96.2	14.98
	14	57.1	8.60	65.9	9.60	79.8	11.37	82.3	12.80	88.7	14.05	93.0	14.22	95.1	15.09
	16	57.1	8.75	65.9	9.80	79.8	11.61	82.3	13.07	88.7	14.34	91.9	14.40	93.8	15.26
	18	57.1	8.92	65.9	10.01	79.8	11.87	82.3	13.45	88.7	15.04	90.6	15.16	92.7	15.74
	20	57.1	9.10	65.9	10.24	79.8	12.63	82.3	14.50	87.4	15.80	89.5	15.92	91.4	16.50
	21	57.1	9.19	65.9	10.57	79.8	13.13	82.3	15.64	86.9	16.18	88.7	16.30	90.8	16.88
	23	57.1	9.63	65.9	11.39	79.8	14.15	82.3	16.64	85.5	16.91	87.7	17.09	89.5	17.67
	25	57.1	10.27	65.9	12.23	79.8	15.20	82.3	17.76	84.5	17.67	86.3	17.85	88.4	18.43
	27	57.1	10.94	65.9	13.14	79.8	16.35	81.3	18.62	83.1	18.44	85.3	18.61	87.1	19.22
	29	57.1	11.67	65.9	14.08	79.8	17.54	79.8	19.70	82.1	19.22	83.9	19.40	86.1	20.01
	31	57.1	12.43	65.9	15.07	79.8	18.80	78.3	20.79	80.7	19.99	82.9	20.16	84.7	20.80
	33	57.1	13.23	65.9	16.13	79.8	19.89	77.9	21.59	79.7	20.75	81.5	20.95	83.7	21.59
	35	57.1	14.07	65.9	17.24	75.5	20.65	75.8	21.86	78.3	21.54	80.2	21.74	82.3	22.38
	37	57.1	15.41	65.9	18.41	73.6	21.44	74.9	21.96	77.0	22.30	79.1	22.53	81.0	23.17
	39	57.1	16.72	65.9	19.67	72.3	22.20	73.5	22.75	75.7	23.09	77.8	23.32	79.9	23.99
	41	57.1	18.04	65.9	19.83	71.0	22.36	72.8	22.92	74.4	23.25	75.3	23.59	77.6	24.16
	43	57.1	19.35	65.9	20.10	69.7	22.53	72.0	23.08	73.2	23.41	74.7	24.21	76.4	24.65
	45	57.1	20.45	65.9	20.81	68.3	22.99	70.7	23.56	71.9	23.89	72.7	24.74	74.7	25.46
48	57.1	23.46	65.9	24.12	67.0	24.78	69.8	25.43	70.7	26.09	71.9	26.74	73.1	27.40	
50	57.1	26.48	64.4	27.14	65.7	27.79	68.7	28.45	69.4	29.10	70.3	29.76	71.5	30.41	
52	57.1	29.50	63.0	30.15	64.4	30.81	67.7	31.46	68.2	32.12	68.9	32.77	69.9	33.43	
54	57.1	32.51	61.5	33.17	63.0	33.82	66.6	34.48	66.9	35.14	67.5	35.79	68.2	36.45	
100%	-5	51.2	7.69	60.1	8.37	72.0	9.23	73.0	10.84	79.2	10.58	91.0	11.72	93.8	12.92
	-2	51.2	7.79	60.1	8.48	72.0	9.42	73.0	10.92	79.2	10.74	91.0	11.87	93.8	13.01
	0	51.2	7.88	60.1	8.59	72.0	9.58	73.0	11.09	79.2	10.84	91.0	12.09	93.8	13.16
	2	51.2	7.99	60.1	8.70	72.0	9.79	73.0	11.19	79.2	10.97	91.0	12.28	93.8	13.38
	4	51.2	8.07	60.1	8.85	72.0	9.92	73.0	11.36	79.2	11.12	91.0	12.41	93.8	13.53
	6	51.2	8.24	60.1	8.97	72.0	10.09	73.0	11.60	79.2	11.29	91.0	12.60	93.8	13.74
	8	51.2	8.37	60.1	9.16	72.0	10.28	73.0	11.81	79.2	11.49	91.0	12.82	93.8	13.98
	10	51.2	8.54	60.1	9.33	72.0	10.44	73.0	11.99	79.2	11.71	91.0	13.05	93.8	14.18
	12	51.2	8.71	60.1	9.53	72.0	10.84	73.0	12.23	79.2	11.94	91.0	13.31	92.4	14.30
	14	51.2	8.89	60.1	9.74	72.0	11.34	73.0	13.01	79.2	12.17	91.0	13.59	91.4	14.48
	16	51.2	9.06	60.1	9.97	72.0	11.62	73.0	13.34	79.2	12.44	88.3	13.77	90.1	14.65
	18	51.2	9.23	60.1	10.17	72.0	12.06	73.0	13.86	79.2	12.70	87.2	14.26	89.1	15.02
	20	51.2	9.44	60.1	10.52	72.0	13.07	73.0	14.80	79.2	13.65	85.9	14.99	87.8	15.77
	21	51.2	9.52	60.1	10.95	72.0	14.00	73.0	15.71	79.2	14.14	85.4	15.36	87.2	16.15
	23	51.2	10.19	60.1	11.82	72.0	15.06	73.0	16.79	79.2	15.21	84.4	16.11	85.9	16.90
	25	51.2	10.91	60.1	12.74	72.0	16.25	73.0	17.63	79.2	16.34	83.1	16.87	84.9	17.65
	27	51.2	11.66	60.1	13.70	72.0	17.21	73.0	18.69	79.2	17.53	81.8	17.62	83.6	18.44
	29	51.2	12.48	60.1	14.71	72.0	18.50	73.0	19.24	78.9	18.66	80.7	19.04	82.5	19.19
	31	51.2	13.34	60.1	15.78	72.0	19.78	73.0	19.59	77.8	19.41	79.4	19.73	81.2	19.97
	33	51.2	14.24	60.1	16.91	72.0	20.73	73.0	20.15	76.5	20.16	78.4	20.45	80.2	20.75
	35	51.2	15.17	60.1	18.13	72.0	21.15	73.0	21.47	75.2	21.50	77.1	21.72	78.9	21.93
	37	51.2	16.18	60.1	19.40	72.0	21.30	72.1	22.45	74.5	22.77	76.0	23.05	77.6	23.36
	39	51.2	17.22	60.1	20.73	72.0	21.69	71.1	23.32	73.5	23.71	74.7	24.19	76.5	24.38
	41	51.2	17.87	60.1	21.54	72.0	22.01	70.2	24.16	72.5	24.65	72.0	24.88	75.5	25.15
	43	51.2	18.51	60.1	21.96	72.0	22.74	70.0	25.30	71.4	25.71	72.4	26.14	72.7	26.34
	45	51.2	19.37	60.1	22.57	72.0	24.17	69.5	26.91	70.4	28.40	71.8	29.82	71.5	30.40
48	51.2	22.33	60.1	24.05	72.0	25.77	68.7	28.99	69.4	30.70	70.2	32.42	70.5	34.14	
50	51.2	25.29	60.1	27.01	72.0	28.73	68.1	30.45	68.4	32.16	69.1	33.88	69.4	35.60	
52	51.2	28.26	60.1	29.97	72.0	31.69	67.5	33.41	67.4	35.13	68.0	36.84	68.3	38.56	
54	51.2	31.22	60.1	32.94	72.0	34.65	66.9	36.37	66.4	38.09	66.9	39.81	67.3	41.53	

Обозначения:

CR: Индекс установленной мощности;
 ТС: Полная производительность (кВт);
 PI: Потребляемая мощность (компрессор + двигатель вентилятора наружного блока) (кВт)

Примечание: 1. В серых ячейках указаны расчётные значения.

Продолжение таблицы на следующей странице...

Таблица 2-8.5: Таблица холодопроизводительности для блоков производительностью 26 л.с. (продолжение)

CR	Температура наружного воздуха (°C DB)	Температура в помещении (°C DB/WD)													
		20.8/14		23.3/16		25.8/18		27/19		28.2/20		30.7/22		32/24	
		ТС	PI	ТС	PI	ТС	PI	ТС	PI	ТС	PI	ТС	PI	ТС	PI
		кВт	кВт	кВт	кВт	кВт	кВт	кВт	кВт	кВт	кВт	кВт	кВт	кВт	кВт
90%	-5	44.5	6.15	53.1	6.70	61.7	7.39	65.9	8.67	71.4	8.47	81.4	9.38	87.4	10.34
	-2	44.5	6.23	53.1	6.78	61.7	7.54	65.9	8.74	71.4	8.59	81.4	9.50	87.4	10.41
	0	44.5	6.30	53.1	6.87	61.7	7.66	65.9	8.87	71.4	8.67	81.4	9.67	87.4	10.53
	2	44.5	6.39	53.1	6.96	61.7	7.84	65.9	8.95	71.4	8.78	81.4	9.82	87.4	10.70
	4	44.5	6.46	53.1	7.08	61.7	7.94	65.9	9.08	71.4	8.90	81.4	9.93	87.4	10.82
	6	44.5	6.60	53.1	7.18	61.7	8.07	65.9	9.28	71.4	9.03	81.4	10.08	87.4	10.99
	8	44.5	6.70	53.1	7.33	61.7	8.22	65.9	9.45	71.4	9.19	81.4	10.25	87.4	11.18
	10	44.5	6.83	53.1	7.46	61.7	8.35	65.9	9.59	71.4	9.37	81.4	10.44	87.4	11.35
	12	44.5	6.97	53.1	7.63	61.7	8.67	65.9	9.78	71.4	9.56	81.4	10.65	87.4	11.44
	14	44.5	7.11	53.1	7.79	61.7	9.08	65.9	10.41	71.4	9.74	81.4	10.88	87.4	11.58
	16	44.5	7.25	53.1	7.97	61.7	9.30	65.9	10.67	71.4	9.95	81.4	11.02	87.4	11.72
	18	44.5	7.39	53.1	8.14	61.7	9.65	65.9	11.09	71.4	10.16	81.4	11.41	87.4	12.02
	20	44.5	7.55	53.1	8.41	61.7	10.46	65.9	11.84	71.4	10.92	81.4	11.99	87.4	12.62
	21	44.5	7.62	53.1	8.76	61.7	11.20	65.9	12.56	71.4	11.31	81.4	12.29	87.4	12.92
	23	44.5	8.15	53.1	9.46	61.7	12.05	65.9	13.43	71.4	12.17	81.4	12.89	87.4	13.52
	25	44.5	8.73	53.1	10.20	61.7	13.00	65.9	14.10	71.4	13.07	81.4	13.49	87.4	14.12
	27	44.5	9.33	53.1	10.96	61.7	13.77	65.9	14.95	71.4	14.02	81.4	14.09	87.4	14.75
	29	44.5	9.98	53.1	11.77	61.7	14.80	65.9	15.39	71.4	14.92	81.4	15.24	87.4	15.35
	31	44.5	10.67	53.1	12.63	61.7	15.83	65.9	15.67	71.4	15.53	81.4	15.78	87.4	15.98
	33	44.5	11.39	53.1	13.53	61.7	16.58	65.9	16.12	71.4	16.13	81.4	16.36	87.4	16.60
	35	44.5	12.13	53.1	14.50	61.7	16.92	65.9	17.18	71.4	17.20	81.4	17.38	87.4	17.55
	37	44.5	12.94	53.1	15.52	61.7	17.04	65.9	17.94	71.4	18.21	81.4	18.44	87.4	18.69
	39	44.5	13.78	53.1	16.59	61.7	17.35	65.9	18.24	71.4	18.97	81.4	19.35	87.4	19.51
	41	44.5	14.29	53.1	17.23	61.7	17.61	65.9	18.58	71.4	19.72	81.4	19.91	87.4	20.12
43	44.5	14.81	53.1	17.57	61.7	18.19	65.9	18.93	71.4	20.56	81.4	20.92	87.4	21.07	
45	44.5	15.49	53.1	18.06	61.7	19.33	65.9	19.26	71.4	21.00	81.4	21.80	87.4	22.25	
48	44.5	17.86	53.1	18.72	61.7	19.58	65.9	20.44	71.4	21.30	81.4	22.16	87.4	23.02	
50	44.5	20.24	53.1	21.09	61.7	21.95	65.9	22.81	71.4	23.67	81.4	24.53	87.4	25.39	
52	44.5	22.61	53.1	23.46	61.7	24.32	65.9	25.18	71.4	26.04	81.4	26.90	87.4	27.76	
54	44.5	24.98	53.1	25.83	61.7	26.69	65.9	27.55	71.4	28.41	81.4	29.27	87.4	30.13	
80%	-5	39.6	4.71	47.2	4.86	54.8	5.65	58.8	5.27	63.9	7.02	72.7	8.07	77.9	9.24
	-2	39.6	4.77	47.2	4.92	54.8	5.73	58.8	5.29	63.9	7.10	72.7	8.15	77.9	9.33
	0	39.6	4.82	47.2	4.98	54.8	5.82	58.8	5.40	63.9	7.19	72.7	8.24	77.9	9.40
	2	39.6	4.89	47.2	5.05	54.8	5.89	58.8	5.64	63.9	7.31	72.7	8.41	77.9	9.54
	4	39.6	4.94	47.2	5.13	54.8	5.99	58.8	5.65	63.9	7.40	72.7	8.54	77.9	9.68
	6	39.6	5.05	47.2	5.23	54.8	6.11	58.8	5.81	63.9	7.53	72.7	8.68	77.9	9.84
	8	39.6	5.13	47.2	5.34	54.8	6.24	58.8	6.03	63.9	7.66	72.7	8.84	77.9	9.94
	10	39.6	5.23	47.2	5.46	54.8	6.36	58.8	6.10	63.9	7.84	72.7	8.95	77.9	10.10
	12	39.6	5.34	47.2	5.56	54.8	6.49	58.8	6.25	63.9	7.98	72.7	9.12	77.9	10.28
	14	39.6	5.44	47.2	5.67	54.8	6.61	58.8	6.38	63.9	8.13	72.7	9.29	77.9	10.47
	16	39.6	5.55	47.2	5.77	54.8	6.76	58.8	6.53	63.9	8.29	72.7	9.47	77.9	10.66
	18	39.6	5.65	47.2	5.90	54.8	6.88	58.8	6.76	63.9	8.46	72.7	9.66	77.9	10.99
	20	39.6	5.78	47.2	6.04	54.8	7.03	58.8	7.36	63.9	8.77	72.7	10.39	77.9	11.51
	21	39.6	5.83	47.2	6.08	54.8	7.15	58.8	7.91	63.9	9.08	72.7	10.76	77.9	11.78
	23	39.6	6.24	47.2	6.33	54.8	7.69	58.8	8.57	63.9	9.74	72.7	11.55	77.9	12.31
	25	39.6	6.68	47.2	6.79	54.8	8.25	58.8	9.22	63.9	10.41	72.7	12.36	77.9	12.85
	27	39.6	7.14	47.2	7.24	54.8	8.83	58.8	10.11	63.9	11.13	72.7	13.23	77.9	13.39
	29	39.6	7.64	47.2	7.74	54.8	9.45	58.8	10.53	63.9	11.90	72.7	13.83	77.9	13.93
	31	39.6	8.17	47.2	8.26	54.8	10.10	58.8	11.26	63.9	12.69	72.7	14.37	77.9	14.49
	33	39.6	8.72	47.2	8.80	54.8	10.80	58.8	11.99	63.9	13.54	72.7	14.93	77.9	15.03
	35	39.6	9.28	47.2	9.38	54.8	11.53	58.8	13.14	63.9	14.43	72.7	15.47	77.9	15.59
	37	39.6	9.91	47.2	9.98	54.8	12.29	58.8	13.74	63.9	15.38	72.7	16.01	77.9	16.13
	39	39.6	10.54	47.2	10.64	54.8	13.10	58.8	14.28	63.9	16.40	72.7	16.57	77.9	16.69
	41	39.6	10.94	47.2	11.14	54.8	13.59	58.8	14.79	63.9	16.48	72.7	16.99	77.9	17.08
43	39.6	11.33	47.2	11.63	54.8	14.09	58.8	15.49	63.9	16.83	72.7	17.21	77.9	17.35	
45	39.6	11.86	47.2	12.22	54.8	14.68	58.8	16.47	63.9	17.30	72.7	17.39	77.9	17.58	
48	39.6	13.67	47.2	14.72	54.8	15.77	58.8	16.83	63.9	17.88	72.7	18.93	77.9	19.98	
50	39.6	15.48	47.2	16.54	54.8	17.59	58.8	18.64	63.9	19.69	72.7	20.74	77.9	21.79	
52	39.6	17.30	47.2	18.35	54.8	19.40	58.8	20.45	63.9	21.50	72.7	22.56	77.9	23.61	
54	39.6	19.11	47.2	20.16	54.8	21.22	58.8	22.27	63.9	23.32	72.7	24.37	77.9	25.42	

Обозначения:

- CR: Индекс установленной мощности;
- ТС: Полная производительность (кВт);
- PI: Потребляемая мощность (компрессор + двигатель вентилятора наружного блока) (кВт)

Примечание: 1. В серых ячейках указаны расчётные значения.

Продолжение таблицы на следующей странице...

Таблица 2-8.5: Таблица холодопроизводительности для блоков производительностью 26 л.с. (продолжение)

CR	Температура наружного воздуха (°C DB)	Температура в помещении (°C DB/WD)													
		20.8/14		23.3/16		25.8/18		27/19		28.2/20		30.7/22		32/24	
		ТС	PI	ТС	PI	ТС	PI	ТС	PI	ТС	PI	ТС	PI	ТС	PI
		кВт	кВт	кВт	кВт	кВт	кВт	кВт	кВт	кВт	кВт	кВт	кВт	кВт	кВт
70%	-5	34.7	3.82	41.5	3.94	48.1	4.58	51.5	5.29	56.0	5.69	63.6	6.54	68.4	7.49
	-2	34.7	3.87	41.5	3.99	48.1	4.65	51.5	5.32	56.0	5.76	63.6	6.61	68.4	7.57
	0	34.7	3.91	41.5	4.04	48.1	4.72	51.5	5.34	56.0	5.83	63.6	6.68	68.4	7.63
	2	34.7	3.97	41.5	4.09	48.1	4.77	51.5	5.49	56.0	5.93	63.6	6.82	68.4	7.74
	4	34.7	4.01	41.5	4.16	48.1	4.86	51.5	5.58	56.0	6.00	63.6	6.93	68.4	7.85
	6	34.7	4.09	41.5	4.24	48.1	4.96	51.5	5.68	56.0	6.11	63.6	7.04	68.4	7.98
	8	34.7	4.16	41.5	4.33	48.1	5.06	51.5	5.78	56.0	6.21	63.6	7.17	68.4	8.06
	10	34.7	4.24	41.5	4.43	48.1	5.16	51.5	5.88	56.0	6.35	63.6	7.26	68.4	8.19
	12	34.7	4.33	41.5	4.51	48.1	5.26	51.5	5.99	56.0	6.47	63.6	7.40	68.4	8.34
	14	34.7	4.41	41.5	4.59	48.1	5.36	51.5	6.18	56.0	6.59	63.6	7.53	68.4	8.49
	16	34.7	4.50	41.5	4.68	48.1	5.48	51.5	6.20	56.0	6.72	63.6	7.68	68.4	8.64
	18	34.7	4.58	41.5	4.78	48.1	5.58	51.5	6.22	56.0	6.86	63.6	7.83	68.4	8.91
	20	34.7	4.69	41.5	4.89	48.1	5.70	51.5	6.63	56.0	7.11	63.6	8.42	68.4	9.33
	21	34.7	4.73	41.5	4.93	48.1	5.80	51.5	7.10	56.0	7.36	63.6	8.72	68.4	9.55
	23	34.7	5.06	41.5	5.13	48.1	6.24	51.5	7.48	56.0	7.90	63.6	9.36	68.4	9.99
	25	34.7	5.42	41.5	5.50	48.1	6.69	51.5	8.04	56.0	8.44	63.6	10.02	68.4	10.42
	27	34.7	5.79	41.5	5.87	48.1	7.16	51.5	8.61	56.0	9.03	63.6	10.72	68.4	10.86
	29	34.7	6.19	41.5	6.28	48.1	7.67	51.5	9.01	56.0	9.65	63.6	11.21	68.4	11.30
	31	34.7	6.62	41.5	6.70	48.1	8.19	51.5	9.61	56.0	10.29	63.6	11.65	68.4	11.75
	33	34.7	7.07	41.5	7.13	48.1	8.76	51.5	10.19	56.0	10.98	63.6	12.10	68.4	12.19
	35	34.7	7.53	41.5	7.60	48.1	9.35	51.5	10.66	56.0	11.70	63.6	12.54	68.4	12.64
	37	34.7	8.03	41.5	8.09	48.1	9.97	51.5	11.14	56.0	12.47	63.6	12.98	68.4	13.08
	39	34.7	8.55	41.5	8.63	48.1	10.62	51.5	11.58	56.0	13.30	63.6	13.43	68.4	13.53
	41	34.7	8.87	41.5	9.03	48.1	11.02	51.5	11.99	56.0	13.36	63.6	13.77	68.4	13.85
	43	34.7	9.19	41.5	9.43	48.1	11.42	51.5	12.56	56.0	13.65	63.6	13.95	68.4	14.07
	45	34.7	9.61	41.5	9.91	48.1	11.90	51.5	13.36	56.0	14.02	63.6	15.16	68.4	15.81
48	34.7	11.09	41.5	12.15	48.1	13.22	51.5	14.28	56.0	15.35	63.6	16.41	68.4	17.48	
50	34.7	12.56	41.5	13.62	48.1	14.69	51.5	15.75	56.0	16.82	63.6	17.88	68.4	18.95	
52	34.7	14.03	41.5	15.09	48.1	16.16	51.5	17.22	56.0	18.29	63.6	19.36	68.4	20.42	
54	34.7	15.50	41.5	16.56	48.1	17.63	51.5	18.69	56.0	19.76	63.6	20.83	68.4	21.89	
60%	-5	29.6	3.08	35.4	3.35	41.1	3.69	44.0	4.73	47.8	5.16	54.4	5.73	58.4	6.57
	-2	29.6	3.12	35.4	3.39	41.1	3.75	44.0	4.79	47.8	5.24	54.4	5.82	58.4	6.62
	0	29.6	3.15	35.4	3.44	41.1	3.81	44.0	4.85	47.8	5.31	54.4	5.90	58.4	6.70
	2	29.6	3.20	35.4	3.48	41.1	3.85	44.0	4.95	47.8	5.39	54.4	6.02	58.4	6.79
	4	29.6	3.23	35.4	3.54	41.1	3.92	44.0	5.01	47.8	5.50	54.4	6.12	58.4	6.88
	6	29.6	3.30	35.4	3.59	41.1	4.00	44.0	5.12	47.8	5.61	54.4	6.24	58.4	7.05
	8	29.6	3.35	35.4	3.67	41.1	4.08	44.0	5.22	47.8	5.72	54.4	6.36	58.4	7.16
	10	29.6	3.42	35.4	3.73	41.1	4.16	44.0	5.36	47.8	5.82	54.4	6.48	58.4	7.14
	12	29.6	3.49	35.4	3.81	41.1	4.24	44.0	5.46	47.8	5.93	54.4	6.60	58.4	7.26
	14	29.6	3.56	35.4	3.90	41.1	4.32	44.0	5.55	47.8	6.03	54.4	6.72	58.4	7.38
	16	29.6	3.63	35.4	3.99	41.1	4.42	44.0	5.65	47.8	6.15	54.4	6.84	58.4	7.52
	18	29.6	3.70	35.4	4.07	41.1	4.50	44.0	5.74	47.8	6.27	54.4	6.95	58.4	7.67
	20	29.6	3.78	35.4	4.21	41.1	4.59	44.0	5.86	47.8	6.31	54.4	7.10	58.4	7.81
	21	29.6	3.81	35.4	4.38	41.1	4.68	44.0	6.29	47.8	6.43	54.4	7.17	58.4	7.98
	23	29.6	4.08	35.4	4.73	41.1	5.03	44.0	6.71	47.8	6.84	54.4	7.45	58.4	8.05
	25	29.6	4.37	35.4	5.10	41.1	5.39	44.0	7.08	47.8	7.29	54.4	7.95	58.4	8.57
	27	29.6	4.67	35.4	5.48	41.1	5.77	44.0	7.43	47.8	7.76	54.4	8.47	58.4	9.14
	29	29.6	4.99	35.4	5.89	41.1	6.18	44.0	7.75	47.8	8.26	54.4	9.04	58.4	9.75
	31	29.6	5.34	35.4	6.32	41.1	6.60	44.0	8.17	47.8	8.78	54.4	9.61	58.4	10.42
	33	29.6	5.70	35.4	6.77	41.1	7.06	44.0	8.52	47.8	9.33	54.4	10.23	58.4	11.08
	35	29.6	6.07	35.4	7.25	41.1	7.53	44.0	8.59	47.8	9.90	54.4	10.90	58.4	11.82
	37	29.6	6.48	35.4	7.76	41.1	8.04	44.0	8.98	47.8	10.52	54.4	11.58	58.4	12.58
	39	29.6	6.89	35.4	8.30	41.1	8.56	44.0	9.33	47.8	10.90	54.4	12.29	58.4	13.39
	41	29.6	7.15	35.4	8.62	41.1	8.89	44.0	9.67	47.8	11.28	54.4	12.87	58.4	14.24
	43	29.6	7.41	35.4	8.79	41.1	9.21	44.0	10.13	47.8	11.84	54.4	13.42	58.4	14.89
	45	29.6	8.01	35.4	9.89	41.1	10.46	44.0	11.03	47.8	12.80	54.4	14.02	58.4	15.53
48	29.6	9.19	35.4	10.31	41.1	11.43	44.0	12.55	47.8	13.66	54.4	14.78	58.4	15.90	
50	29.6	10.38	35.4	11.50	41.1	12.61	44.0	13.73	47.8	14.85	54.4	15.97	58.4	17.08	
52	29.6	11.57	35.4	12.68	41.1	13.80	44.0	14.92	47.8	16.03	54.4	17.15	58.4	18.27	
54	29.6	12.75	35.4	13.87	41.1	14.99	44.0	16.10	47.8	17.22	54.4	18.34	58.4	19.45	

Обозначения:

CR: Индекс установленной мощности;

ТС: Полная производительность (кВт);

PI: Потребляемая мощность (компрессор + двигатель вентилятора наружного блока) (кВт)

Примечание: 1. В серых ячейках указаны расчётные значения.

Продолжение таблицы на следующей странице...

MVS FDC II-S

Таблица 2-8.5: Таблица холодопроизводительности для блоков производительностью 26 л.с. (продолжение)

CR	Температура наружного воздуха (°C DB)	Температура в помещении (°C DB/WD)													
		20.8/14		23.3/16		25.8/18		27/19		28.2/20		30.7/22		32/24	
		ТС кВт	PI кВт	ТС кВт	PI кВт	ТС кВт	PI кВт	ТС кВт	PI кВт	ТС кВт	PI кВт	ТС кВт	PI кВт	ТС кВт	PI кВт
50%	-5	24.9	2.55	29.8	2.77	34.5	3.06	36.9	4.20	40.0	4.35	45.5	4.95	49.0	5.34
	-2	24.9	2.58	29.8	2.81	34.5	3.10	36.9	4.30	40.0	4.43	45.5	5.02	49.0	5.41
	0	24.9	2.61	29.8	2.85	34.5	3.15	36.9	4.32	40.0	4.48	45.5	5.10	49.0	5.50
	2	24.9	2.65	29.8	2.88	34.5	3.19	36.9	4.33	40.0	4.56	45.5	5.12	49.0	5.61
	4	24.9	2.68	29.8	2.93	34.5	3.24	36.9	4.34	40.0	4.65	45.5	5.25	49.0	5.75
	6	24.9	2.73	29.8	2.97	34.5	3.31	36.9	4.38	40.0	4.74	45.5	5.33	49.0	5.92
	8	24.9	2.77	29.8	3.04	34.5	3.38	36.9	4.40	40.0	4.80	45.5	5.42	49.0	6.11
	10	24.9	2.83	29.8	3.09	34.5	3.45	36.9	4.36	40.0	4.94	45.5	5.56	49.0	6.20
	12	24.9	2.89	29.8	3.16	34.5	3.51	36.9	4.38	40.0	5.04	45.5	5.66	49.0	6.30
	14	24.9	2.95	29.8	3.23	34.5	3.58	36.9	4.40	40.0	5.11	45.5	5.76	49.0	6.42
	16	24.9	3.00	29.8	3.30	34.5	3.66	36.9	4.41	40.0	5.19	45.5	5.86	49.0	6.52
	18	24.9	3.06	29.8	3.37	34.5	3.73	36.9	4.43	40.0	5.29	45.5	5.95	49.0	6.65
	20	24.9	3.13	29.8	3.49	34.5	3.80	36.9	4.64	40.0	5.39	45.5	6.05	49.0	6.77
	21	24.9	3.16	29.8	3.63	34.5	3.87	36.9	4.88	40.0	5.44	45.5	6.13	49.0	6.84
	23	24.9	3.38	29.8	3.92	34.5	4.16	36.9	5.20	40.0	5.53	45.5	6.23	49.0	6.99
	25	24.9	3.62	29.8	4.22	34.5	4.47	36.9	5.54	40.0	5.71	45.5	6.55	49.0	7.46
	27	24.9	3.87	29.8	4.54	34.5	4.78	36.9	5.97	40.0	6.05	45.5	6.97	49.0	7.96
	29	24.9	4.13	29.8	4.88	34.5	5.12	36.9	6.15	40.0	6.45	45.5	7.41	49.0	8.47
	31	24.9	4.42	29.8	5.23	34.5	5.47	36.9	6.56	40.0	6.84	45.5	7.88	49.0	9.02
	33	24.9	4.72	29.8	5.60	34.5	5.85	36.9	6.91	40.0	7.26	45.5	8.38	49.0	9.59
	35	24.9	5.03	29.8	6.01	34.5	6.24	36.9	7.12	40.0	7.68	45.5	8.89	49.0	10.18
37	24.9	5.36	29.8	6.43	34.5	6.65	36.9	7.44	40.0	8.15	45.5	9.44	49.0	10.82	
39	24.9	5.71	29.8	6.87	34.5	7.09	36.9	7.73	40.0	8.65	45.5	10.01	49.0	11.49	
41	24.9	5.92	29.8	7.14	34.5	7.36	36.9	8.01	40.0	9.02	45.5	10.54	49.0	12.02	
43	24.9	6.13	29.8	7.28	34.5	7.63	36.9	8.53	40.0	9.25	45.5	11.07	49.0	12.56	
45	24.9	6.42	29.8	8.19	34.5	8.73	36.9	9.42	40.0	10.34	45.5	12.14	49.0	13.09	
48	24.9	7.54	29.8	8.61	34.5	9.68	36.9	10.74	40.0	11.81	45.5	12.88	49.0	13.95	
50	24.9	8.67	29.8	9.73	34.5	10.80	36.9	11.87	40.0	12.94	45.5	14.00	49.0	15.07	
52	24.9	9.79	29.8	10.86	34.5	11.93	36.9	12.99	40.0	14.06	45.5	15.13	49.0	16.19	
54	24.9	10.92	29.8	11.98	34.5	13.05	36.9	14.12	40.0	15.18	45.5	16.25	49.0	17.32	

Обозначения:

CR: Индекс установленной мощности;

ТС: Полная производительность (кВт);

PI: Потребляемая мощность (компрессор + двигатель вентилятора наружного блока) (кВт)

Примечание: 1. В серых ячейках указаны расчётные значения.

Таблица 2-8.6: Таблица холодопроизводительности для блоков производительностью 28 л.с.

CR	Температура наружного воздуха (°C DB)	Температура в помещении (°C DB/WD)													
		20.8/14		23.3/16		25.8/18		27/19		28.2/20		30.7/22		32/24	
		ТС	PI	ТС	PI	ТС	PI	ТС	PI	ТС	PI	ТС	PI	ТС	PI
		кВт	кВт	кВт	кВт	кВт	кВт	кВт	кВт	кВт	кВт	кВт	кВт	кВт	кВт
130%	-5	71.1	10.30	86.4	11.55	97.5	12.45	100.3	13.52	107.3	14.43	110.2	15.69	111.1	15.79
	-2	71.1	10.30	86.4	11.79	97.5	12.45	101.2	13.60	107.3	14.43	110.2	15.89	111.1	15.95
	0	71.1	10.48	86.4	12.01	97.5	12.95	101.2	14.37	107.3	15.27	110.2	16.08	111.1	16.16
	2	71.1	10.67	86.4	12.04	97.5	13.43	101.2	15.21	107.3	15.44	110.2	16.20	111.1	16.40
	4	71.1	10.91	86.4	12.30	97.5	13.92	101.2	15.28	107.3	15.64	110.2	16.19	111.1	16.71
	6	71.1	11.12	86.4	12.56	97.5	14.48	101.2	15.41	105.4	16.13	107.0	16.19	111.1	16.83
	8	71.1	11.38	86.4	12.87	97.5	15.25	101.2	16.19	104.4	16.66	105.9	16.27	109.9	17.00
	10	71.1	11.62	86.4	13.17	97.5	15.86	101.2	16.75	103.4	16.77	105.5	16.77	108.5	17.49
	12	71.1	11.82	86.4	13.44	97.5	16.20	100.1	16.94	101.9	17.21	104.7	17.07	107.4	17.60
	14	71.1	12.06	86.4	13.72	96.9	16.27	99.3	17.03	100.7	17.37	103.9	17.36	106.0	18.00
	16	71.1	12.27	86.4	14.02	95.8	16.72	97.5	17.37	99.4	17.73	103.2	17.77	105.0	18.28
	18	71.1	12.50	86.4	14.33	94.3	16.98	95.9	17.60	98.1	18.21	102.4	18.38	104.0	18.55
	20	71.1	12.78	86.4	15.31	93.4	17.86	94.5	18.48	96.8	19.09	101.7	19.26	103.0	19.47
	21	71.1	13.11	86.4	15.89	92.9	18.30	94.8	18.92	95.6	19.54	101.0	19.74	102.1	19.91
	23	71.1	14.07	86.4	17.11	91.2	19.19	92.7	19.80	94.3	20.42	100.2	20.62	101.1	20.83
	25	71.1	15.02	86.4	18.41	89.8	20.07	91.3	20.69	93.0	21.34	99.5	21.54	100.1	21.74
	27	71.1	16.04	86.4	19.77	88.6	20.95	90.0	22.02	91.7	22.22	98.8	22.46	99.1	22.70
	29	71.1	17.12	86.4	21.19	87.2	21.84	88.8	23.20	90.5	23.14	98.0	23.38	98.1	23.61
	31	71.1	18.28	83.5	22.48	85.9	22.75	87.6	24.35	89.2	24.02	97.3	24.29	97.1	24.57
	33	71.1	19.47	82.0	23.37	84.6	23.64	86.1	25.68	87.9	24.94	96.5	25.21	96.2	25.48
	35	71.1	20.76	80.6	24.25	83.4	24.55	84.6	25.72	86.6	25.86	95.8	26.16	95.2	26.43
	37	71.1	22.09	79.5	25.34	82.1	25.47	83.6	26.12	85.4	26.81	95.1	27.11	94.2	27.42
	39	71.1	23.51	78.0	26.34	80.6	26.47	82.3	27.04	84.6	27.72	94.3	28.03	93.2	28.37
	41	71.1	24.75	77.2	27.35	79.8	27.46	81.0	27.95	82.3	28.50	94.9	28.79	92.2	29.14
	43	71.1	25.72	76.7	28.35	79.4	29.23	79.7	29.64	81.5	29.95	93.4	30.21	91.3	30.49
	45	71.1	26.70	76.2	29.62	78.5	30.48	78.4	31.07	80.3	31.37	91.1	31.57	90.3	32.24
48	71.1	30.25	75.7	31.02	77.7	31.79	77.1	32.56	79.1	33.34	88.8	34.11	89.3	34.88	
50	71.1	33.80	73.4	34.57	76.0	35.34	75.7	36.11	77.7	36.88	87.0	37.66	88.3	38.43	
52	71.1	37.35	72.3	38.12	75.0	38.89	74.4	39.66	76.4	40.43	85.6	41.21	87.3	41.98	
54	71.1	40.90	71.1	41.67	73.9	42.44	73.1	43.21	75.2	43.98	84.6	44.76	86.3	45.53	
120%	-5	66.5	9.94	77.2	10.76	89.7	12.45	97.6	14.00	102.2	14.91	104.5	16.19	106.8	16.64
	-2	66.5	10.04	77.2	10.89	89.7	12.59	97.6	14.09	102.2	15.10	104.5	16.33	106.8	16.70
	0	66.5	10.13	77.2	10.97	89.7	12.76	97.6	14.12	102.2	15.25	104.5	16.43	106.8	16.73
	2	66.5	10.16	77.2	11.10	89.7	12.86	97.6	14.27	102.2	15.31	104.5	16.56	106.8	16.77
	4	66.5	10.26	77.2	11.26	89.7	13.07	97.6	14.42	102.2	15.53	104.5	16.59	106.8	16.81
	6	66.5	10.37	77.2	11.36	89.7	13.24	97.6	14.60	102.2	15.71	104.5	16.73	106.8	16.87
	8	66.5	10.46	77.2	11.48	89.7	13.45	97.6	14.80	102.2	15.89	104.5	16.79	106.8	16.95
	10	66.5	10.59	77.2	11.65	89.7	13.59	97.6	15.10	102.2	15.90	104.5	16.84	106.8	17.03
	12	66.5	10.79	77.2	11.89	89.7	13.89	97.6	15.40	100.8	15.97	103.1	16.74	105.4	17.14
	14	66.5	11.00	77.2	12.16	89.7	14.20	97.6	15.74	99.4	16.08	102.0	17.01	104.2	17.35
	16	66.5	11.20	77.2	12.43	89.7	14.50	97.4	15.97	98.2	16.33	100.5	17.30	102.8	17.62
	18	66.5	11.40	77.2	12.71	89.7	15.05	95.5	16.45	96.8	16.78	99.1	17.71	101.7	17.88
	20	66.5	11.64	77.2	13.25	89.7	16.33	94.5	17.34	95.7	17.66	98.0	18.60	100.3	18.76
	21	66.5	11.74	77.2	13.76	89.7	16.98	92.8	18.41	94.8	18.10	97.4	19.04	99.7	19.24
	23	66.5	12.55	77.2	14.84	89.7	18.30	90.9	19.88	93.7	18.98	96.0	19.95	98.2	20.12
	25	66.5	13.40	77.2	15.96	88.3	19.18	89.8	20.73	92.2	19.87	94.8	20.83	97.1	21.04
	27	66.5	14.32	77.2	17.15	87.2	20.03	88.4	22.08	91.1	20.78	93.4	21.75	95.7	21.95
	29	66.5	15.27	77.2	18.41	85.7	20.91	86.9	23.02	89.7	21.66	92.0	22.67	94.5	22.87
	31	66.5	16.29	77.2	19.73	84.4	21.83	85.7	24.16	88.5	22.58	90.8	23.58	93.1	23.82
	33	66.5	17.34	77.2	21.12	83.2	22.71	84.4	25.18	87.1	23.46	89.4	24.50	91.7	24.74
	35	66.5	18.46	77.2	22.61	81.8	23.59	82.9	25.52	86.0	24.38	88.2	25.42	90.5	25.69
	37	66.5	19.65	77.2	24.17	80.6	24.51	81.8	25.67	83.7	25.82	86.8	26.33	89.1	26.64
	39	66.5	20.90	76.9	25.60	79.2	25.40	80.4	25.82	82.3	26.21	85.7	27.28	88.0	27.55
	41	66.5	22.06	76.3	25.79	78.5	26.29	79.7	27.03	80.8	27.13	83.4	28.19	85.5	28.49
	43	66.5	23.02	75.8	25.98	77.9	27.03	79.1	27.63	80.2	28.04	81.9	29.12	84.2	29.43
	45	66.5	23.99	75.4	26.24	77.2	27.56	78.2	28.60	79.5	28.96	80.3	30.04	83.6	30.36
48	66.5	27.52	75.0	28.28	76.5	29.05	77.5	29.81	78.9	30.58	78.8	31.34	82.5	32.11	
50	66.5	31.04	74.5	31.80	75.6	32.57	76.6	33.33	77.6	34.10	77.0	34.87	80.8	35.63	
52	66.5	34.56	74.1	35.32	74.8	36.09	75.8	36.86	76.6	37.62	75.4	38.39	79.4	39.15	
54	66.5	38.08	73.6	38.85	74.1	39.61	75.0	40.38	75.7	41.14	73.7	41.91	78.1	42.67	

Обозначения:

CR: Индекс установленной мощности;

ТС: Полная производительность (кВт);

PI: Потребляемая мощность (компрессор + двигатель вентилятора наружного блока) (кВт)

Примечание: 1. В серых ячейках указаны расчётные значения.

Продолжение таблицы на следующей странице...

MVS FDC II-S

Таблица 2-8.6: Таблица холодопроизводительности для блоков производительностью 28 л.с. (продолжение)

CR	Температура наружного воздуха (°C DB)	Температура в помещении (°C DB/WD)													
		20.8/14		23.3/16		25.8/18		27/19		28.2/20		30.7/22		32/24	
		ТС	PI	ТС	PI	ТС	PI	ТС	PI	ТС	PI	ТС	PI	ТС	PI
		кВт	кВт	кВт	кВт	кВт	кВт	кВт	кВт	кВт	кВт	кВт	кВт	кВт	кВт
110%	-5	61.4	8.69	70.9	9.80	85.8	11.64	88.5	13.09	95.4	14.40	102.5	14.97	104.8	15.96
	-2	61.4	8.85	70.9	9.94	85.8	11.75	88.5	13.23	95.4	14.51	102.5	15.12	104.8	16.04
	0	61.4	8.94	70.9	10.00	85.8	11.84	88.5	13.32	95.4	14.68	102.5	15.28	104.8	16.24
	2	61.4	9.14	70.9	10.11	85.8	12.05	88.5	13.47	95.4	14.84	102.5	15.51	104.8	16.44
	4	61.4	9.32	70.9	10.23	85.8	12.18	88.5	13.65	95.4	15.08	102.5	15.73	104.8	16.59
	6	61.4	9.41	70.9	10.36	85.8	12.31	88.5	13.88	95.4	15.25	102.5	15.90	104.8	16.84
	8	61.4	9.50	70.9	10.54	85.8	12.46	88.5	14.03	95.4	15.43	102.5	16.01	104.8	17.02
	10	61.4	9.61	70.9	10.70	85.8	12.66	88.5	14.28	95.4	15.69	102.5	16.13	104.8	17.17
	12	61.4	9.82	70.9	10.94	85.8	12.93	88.5	14.59	95.4	16.00	101.4	16.37	103.4	17.39
	14	61.4	9.99	70.9	11.14	85.8	13.20	88.5	14.86	95.4	16.30	100.0	16.51	102.3	17.52
	16	61.4	10.16	70.9	11.38	85.8	13.47	88.5	15.17	95.4	16.64	98.8	16.71	100.8	17.71
	18	61.4	10.36	70.9	11.62	85.8	13.78	88.5	15.61	95.4	17.46	97.4	17.59	99.7	18.27
	20	61.4	10.56	70.9	11.89	85.8	14.66	88.5	16.83	94.0	18.34	96.3	18.48	98.3	19.15
	21	61.4	10.66	70.9	12.26	85.8	15.24	88.5	18.15	93.4	18.78	95.4	18.92	97.7	19.59
	23	61.4	11.17	70.9	13.21	85.8	16.43	88.5	19.32	92.0	19.63	94.3	19.83	96.3	20.51
	25	61.4	11.92	70.9	14.20	85.8	17.65	88.5	20.61	90.8	20.51	92.8	20.72	95.1	21.40
	27	61.4	12.70	70.9	15.25	85.8	18.97	87.4	21.61	89.4	21.40	91.7	21.60	93.7	22.31
	29	61.4	13.55	70.9	16.34	85.8	20.36	85.8	22.86	88.3	22.31	90.3	22.52	92.5	23.23
	31	61.4	14.43	70.9	17.49	85.8	21.82	84.2	24.13	86.8	23.20	89.1	23.40	91.1	24.15
	33	61.4	15.35	70.9	18.72	85.8	23.08	83.7	25.06	85.7	24.08	87.7	24.32	90.0	25.06
	35	61.4	16.33	70.9	20.01	81.1	23.96	81.5	25.37	84.2	25.00	86.2	25.23	88.5	25.98
	37	61.4	17.88	70.9	21.37	79.2	24.88	80.6	25.49	82.8	25.88	85.1	26.15	87.1	26.90
	39	61.4	19.41	70.9	22.83	77.8	25.76	79.1	26.41	81.4	26.80	83.7	27.07	86.0	27.85
	41	61.4	20.94	70.9	23.02	76.3	25.95	78.3	26.60	80.0	26.99	81.0	27.39	83.4	28.04
	43	61.4	22.46	70.9	23.33	74.9	26.14	77.4	26.79	78.7	27.18	80.4	28.10	82.2	28.61
	45	61.4	23.73	70.9	24.15	73.5	26.68	76.1	27.34	77.4	27.73	78.2	28.72	80.3	29.56
48	61.4	27.23	70.9	28.00	72.1	28.76	75.0	29.52	76.0	30.28	77.3	31.04	78.6	31.80	
50	61.4	30.74	69.3	31.50	70.6	32.26	73.9	33.02	74.7	33.78	75.6	34.54	76.9	35.30	
52	61.4	34.24	67.7	35.00	69.2	35.76	72.8	36.52	73.3	37.28	74.1	38.04	75.1	38.80	
54	61.4	37.74	66.1	38.50	67.8	39.26	71.7	40.02	72.0	40.78	72.6	41.54	73.4	42.30	
100%	-5	55.1	8.92	64.7	9.72	77.4	10.72	78.5	12.58	85.1	12.29	97.8	13.61	100.8	15.00
	-2	55.1	9.05	64.7	9.84	77.4	10.93	78.5	12.68	85.1	12.46	97.8	13.78	100.8	15.10
	0	55.1	9.15	64.7	9.97	77.4	11.12	78.5	12.87	85.1	12.58	97.8	14.03	100.8	15.28
	2	55.1	9.28	64.7	10.09	77.4	11.37	78.5	12.99	85.1	12.73	97.8	14.25	100.8	15.53
	4	55.1	9.37	64.7	10.27	77.4	11.52	78.5	13.18	85.1	12.91	97.8	14.40	100.8	15.70
	6	55.1	9.57	64.7	10.42	77.4	11.71	78.5	13.46	85.1	13.11	97.8	14.63	100.8	15.95
	8	55.1	9.72	64.7	10.64	77.4	11.93	78.5	13.70	85.1	13.33	97.8	14.88	100.8	16.22
	10	55.1	9.91	64.7	10.83	77.4	12.12	78.5	13.92	85.1	13.59	97.8	15.14	100.8	16.46
	12	55.1	10.12	64.7	11.06	77.4	12.58	78.5	14.19	85.1	13.86	97.8	15.45	99.4	16.59
	14	55.1	10.32	64.7	11.30	77.4	13.17	78.5	15.10	85.1	14.13	97.8	15.78	98.3	16.80
	16	55.1	10.52	64.7	11.57	77.4	13.49	78.5	15.48	85.1	14.43	94.9	15.98	96.9	17.00
	18	55.1	10.72	64.7	11.80	77.4	14.00	78.5	16.09	85.1	14.74	93.8	16.55	95.8	17.44
	20	55.1	10.95	64.7	12.21	77.4	15.17	78.5	17.18	85.1	15.84	92.4	17.39	94.4	18.31
	21	55.1	11.05	64.7	12.71	77.4	16.25	78.5	18.23	85.1	16.41	91.8	17.83	93.8	18.74
	23	55.1	11.83	64.7	13.72	77.4	17.48	78.5	19.48	85.1	17.66	90.7	18.70	92.4	19.62
	25	55.1	12.67	64.7	14.79	77.4	18.86	78.5	20.46	85.1	18.97	89.3	19.58	91.3	20.49
	27	55.1	13.54	64.7	15.90	77.4	19.97	78.5	21.69	85.1	20.34	87.9	20.45	89.9	21.40
	29	55.1	14.48	64.7	17.08	77.4	21.48	78.5	22.33	84.8	21.65	86.8	22.10	88.8	22.27
	31	55.1	15.49	64.7	18.32	77.4	22.96	78.5	22.74	83.7	22.53	85.4	22.90	87.4	23.18
	33	55.1	16.53	64.7	19.63	77.4	24.06	78.5	23.38	82.3	23.40	84.3	23.74	86.2	24.09
	35	55.1	17.60	64.7	21.04	77.4	24.55	78.5	24.92	80.9	24.96	82.9	25.21	84.8	25.46
	37	55.1	18.78	64.7	22.52	77.4	24.73	77.5	26.05	80.1	26.43	81.7	26.76	83.4	27.11
	39	55.1	19.99	64.7	24.06	77.4	25.17	76.5	27.07	79.0	27.53	80.4	28.07	82.3	28.30
	41	55.1	20.74	64.7	25.00	77.4	25.55	75.5	28.04	77.9	28.61	77.4	28.88	81.1	29.19
	43	55.1	21.48	64.7	25.49	77.4	26.40	75.3	29.37	76.8	29.84	77.9	30.35	78.2	30.58
	45	55.1	22.48	64.7	26.20	77.4	28.05	74.8	31.23	75.7	32.96	77.2	34.61	76.9	35.28
48	55.1	25.92	64.7	27.91	77.4	29.91	73.9	33.64	74.6	35.64	75.5	37.63	75.8	39.63	
50	55.1	29.36	64.7	31.35	77.4	33.35	73.2	35.34	73.5	37.33	74.3	39.33	74.6	41.32	
52	55.1	32.80	64.7	34.79	77.4	36.78	72.6	38.78	72.4	40.77	73.1	42.77	73.5	44.76	
54	55.1	36.24	64.7	38.23	77.4	40.22	71.9	42.22	71.3	44.21	72.0	46.20	72.3	48.20	

Обозначения:

CR: Индекс установленной мощности;

ТС: Полная производительность (кВт);

PI: Потребляемая мощность (компрессор + двигатель вентилятора наружного блока) (кВт)

Примечание: 1. В серых ячейках указаны расчётные значения.

Продолжение таблицы на следующей странице...

Таблица 2-8.6: Таблица холодопроизводительности для блоков производительностью 28 л.с. (продолжение)

CR	Температура наружного воздуха (°C DB)	Температура в помещении (°C DB/WD)													
		20.8/14		23.3/16		25.8/18		27/19		28.2/20		30.7/22		32/24	
		ТС кВт	PI кВт	ТС кВт	PI кВт	ТС кВт	PI кВт	ТС кВт	PI кВт	ТС кВт	PI кВт	ТС кВт	PI кВт	ТС кВт	PI кВт
90%	-5	47.8	7.14	57.1	7.78	66.4	8.57	70.9	10.06	76.8	9.83	87.5	10.89	94.0	12.00
	-2	47.8	7.24	57.1	7.87	66.4	8.75	70.9	10.14	76.8	9.97	87.5	11.02	94.0	12.08
	0	47.8	7.32	57.1	7.97	66.4	8.89	70.9	10.30	76.8	10.07	87.5	11.22	94.0	12.22
	2	47.8	7.42	57.1	8.07	66.4	9.09	70.9	10.39	76.8	10.19	87.5	11.40	94.0	12.42
	4	47.8	7.50	57.1	8.21	66.4	9.21	70.9	10.54	76.8	10.33	87.5	11.52	94.0	12.56
	6	47.8	7.66	57.1	8.33	66.4	9.37	70.9	10.77	76.8	10.49	87.5	11.70	94.0	12.76
	8	47.8	7.78	57.1	8.51	66.4	9.55	70.9	10.96	76.8	10.67	87.5	11.90	94.0	12.98
	10	47.8	7.93	57.1	8.66	66.4	9.70	70.9	11.13	76.8	10.88	87.5	12.12	94.0	13.17
	12	47.8	8.09	57.1	8.85	66.4	10.06	70.9	11.36	76.8	11.09	87.5	12.36	94.0	13.28
	14	47.8	8.25	57.1	9.04	66.4	10.53	70.9	12.08	76.8	11.30	87.5	12.62	94.0	13.44
	16	47.8	8.41	57.1	9.26	66.4	10.79	70.9	12.38	76.8	11.55	87.5	12.79	94.0	13.60
	18	47.8	8.57	57.1	9.44	66.4	11.20	70.9	12.87	76.8	11.79	87.5	13.24	94.0	13.95
	20	47.8	8.76	57.1	9.77	66.4	12.14	70.9	13.75	76.8	12.68	87.5	13.92	94.0	14.65
	21	47.8	8.84	57.1	10.17	66.4	13.00	70.9	14.58	76.8	13.13	87.5	14.26	94.0	15.00
	23	47.8	9.46	57.1	10.97	66.4	13.99	70.9	15.59	76.8	14.12	87.5	14.96	94.0	15.70
	25	47.8	10.13	57.1	11.83	66.4	15.09	70.9	16.37	76.8	15.17	87.5	15.66	94.0	16.39
	27	47.8	10.83	57.1	12.72	66.4	15.98	70.9	17.35	76.8	16.28	87.5	16.36	94.0	17.12
	29	47.8	11.58	57.1	13.66	66.4	17.18	70.9	17.86	76.8	17.32	87.5	17.68	94.0	17.82
	31	47.8	12.39	57.1	14.65	66.4	18.37	70.9	18.19	76.8	18.02	87.5	18.32	94.0	18.54
	33	47.8	13.22	57.1	15.70	66.4	19.25	70.9	18.71	76.8	18.72	87.5	18.99	94.0	19.27
	35	47.8	14.08	57.1	16.83	66.4	19.64	70.9	19.94	76.8	19.97	87.5	20.17	94.0	20.37
	37	47.8	15.02	57.1	18.01	66.4	19.78	70.9	20.83	76.8	21.14	87.5	21.41	94.0	21.69
	39	47.8	15.99	57.1	19.25	66.4	20.14	70.9	21.17	76.8	22.02	87.5	22.46	94.0	22.64
	41	47.8	16.59	57.1	20.00	66.4	20.44	70.9	21.56	76.8	22.89	87.5	23.11	94.0	23.35
43	47.8	17.19	57.1	20.39	66.4	21.12	70.9	21.97	76.8	23.87	87.5	24.28	94.0	24.46	
45	47.8	17.98	57.1	20.96	66.4	22.44	70.9	22.36	76.8	24.37	87.5	25.30	94.0	25.83	
48	47.8	20.74	57.1	21.73	66.4	22.73	70.9	23.73	76.8	24.72	87.5	25.72	94.0	26.72	
50	47.8	23.49	57.1	24.48	66.4	25.48	70.9	26.48	76.8	27.47	87.5	28.47	94.0	29.47	
52	47.8	26.24	57.1	27.23	66.4	28.23	70.9	29.23	76.8	30.22	87.5	31.22	94.0	32.22	
54	47.8	28.99	57.1	29.99	66.4	30.98	70.9	31.98	76.8	32.98	87.5	33.97	94.0	34.97	
80%	-5	42.6	5.46	50.8	5.64	59.0	6.56	63.2	6.12	68.7	8.15	78.1	9.37	83.8	10.73
	-2	42.6	5.54	50.8	5.71	59.0	6.65	63.2	6.13	68.7	8.25	78.1	9.46	83.8	10.83
	0	42.6	5.60	50.8	5.78	59.0	6.76	63.2	6.27	68.7	8.35	78.1	9.57	83.8	10.92
	2	42.6	5.68	50.8	5.86	59.0	6.83	63.2	6.54	68.7	8.48	78.1	9.76	83.8	11.08
	4	42.6	5.74	50.8	5.95	59.0	6.96	63.2	6.56	68.7	8.59	78.1	9.92	83.8	11.24
	6	42.6	5.86	50.8	6.07	59.0	7.09	63.2	6.74	68.7	8.74	78.1	10.07	83.8	11.43
	8	42.6	5.95	50.8	6.19	59.0	7.25	63.2	7.00	68.7	8.89	78.1	10.26	83.8	11.53
	10	42.6	6.07	50.8	6.34	59.0	7.39	63.2	7.08	68.7	9.10	78.1	10.39	83.8	11.72
	12	42.6	6.19	50.8	6.46	59.0	7.53	63.2	7.25	68.7	9.26	78.1	10.59	83.8	11.93
	14	42.6	6.32	50.8	6.58	59.0	7.68	63.2	7.40	68.7	9.43	78.1	10.78	83.8	12.15
	16	42.6	6.44	50.8	6.70	59.0	7.84	63.2	7.58	68.7	9.63	78.1	11.00	83.8	12.37
	18	42.6	6.56	50.8	6.84	59.0	7.99	63.2	7.85	68.7	9.82	78.1	11.21	83.8	12.75
	20	42.6	6.71	50.8	7.01	59.0	8.16	63.2	8.54	68.7	10.18	78.1	12.06	83.8	13.36
	21	42.6	6.77	50.8	7.06	59.0	8.30	63.2	9.18	68.7	10.54	78.1	12.49	83.8	13.67
	23	42.6	7.24	50.8	7.35	59.0	8.93	63.2	9.95	68.7	11.31	78.1	13.40	83.8	14.29
	25	42.6	7.75	50.8	7.88	59.0	9.58	63.2	10.70	68.7	12.08	78.1	14.34	83.8	14.92
	27	42.6	8.29	50.8	8.41	59.0	10.25	63.2	11.73	68.7	12.92	78.1	15.35	83.8	15.54
	29	42.6	8.87	50.8	8.98	59.0	10.97	63.2	12.22	68.7	13.81	78.1	16.05	83.8	16.17
	31	42.6	9.48	50.8	9.59	59.0	11.72	63.2	13.07	68.7	14.73	78.1	16.68	83.8	16.82
	33	42.6	10.12	50.8	10.21	59.0	12.54	63.2	13.92	68.7	15.71	78.1	17.32	83.8	17.45
	35	42.6	10.78	50.8	10.88	59.0	13.38	63.2	15.26	68.7	16.75	78.1	17.95	83.8	18.10
	37	42.6	11.50	50.8	11.58	59.0	14.27	63.2	15.95	68.7	17.85	78.1	18.58	83.8	18.72
	39	42.6	12.24	50.8	12.35	59.0	15.21	63.2	16.57	68.7	19.04	78.1	19.23	83.8	19.37
	41	42.6	12.69	50.8	12.92	59.0	15.78	63.2	17.16	68.7	19.12	78.1	19.72	83.8	19.83
43	42.6	13.15	50.8	13.50	59.0	16.35	63.2	17.98	68.7	19.53	78.1	19.97	83.8	20.14	
45	42.6	13.76	50.8	14.18	59.0	17.04	63.2	19.12	68.7	20.07	78.1	20.18	83.8	20.40	
48	42.6	15.87	50.8	17.09	59.0	18.31	63.2	19.53	68.7	20.75	78.1	21.97	83.8	23.19	
50	42.6	17.97	50.8	19.19	59.0	20.41	63.2	21.63	68.7	22.86	78.1	24.08	83.8	25.30	
52	42.6	20.08	50.8	21.30	59.0	22.52	63.2	23.74	68.7	24.96	78.1	26.18	83.8	27.40	
54	42.6	22.18	50.8	23.40	59.0	24.62	63.2	25.85	68.7	27.07	78.1	28.29	83.8	29.51	

Обозначения:

CR: Индекс установленной мощности;

ТС: Полная производительность (кВт);

PI: Потребляемая мощность (компрессор + двигатель вентилятора наружного блока) (кВт)

Примечание: 1. В серых ячейках указаны расчётные значения.

Продолжение таблицы на
следующей странице...

MVS FDC II-S

Таблица 2-8.6: Таблица холодопроизводительности для блоков производительностью 28 л.с. (продолжение)

CR	Температура наружного воздуха (°C DB)	Температура в помещении (°C DB/WD)													
		20.8/14		23.3/16		25.8/18		27/19		28.2/20		30.7/22		32/24	
		ТС	PI	ТС	PI	ТС	PI	ТС	PI	ТС	PI	ТС	PI	ТС	PI
		кВт	кВт	кВт	кВт	кВт	кВт	кВт	кВт	кВт	кВт	кВт	кВт	кВт	кВт
70%	-5	37.3	4.43	44.7	4.58	51.7	5.32	55.4	6.14	60.2	6.61	68.4	7.60	73.5	8.70
	-2	37.3	4.49	44.7	4.63	51.7	5.39	55.4	6.17	60.2	6.69	68.4	7.67	73.5	8.78
	0	37.3	4.54	44.7	4.69	51.7	5.48	55.4	6.20	60.2	6.77	68.4	7.76	73.5	8.85
	2	37.3	4.61	44.7	4.75	51.7	5.54	55.4	6.37	60.2	6.88	68.4	7.92	73.5	8.98
	4	37.3	4.65	44.7	4.82	51.7	5.64	55.4	6.47	60.2	6.96	68.4	8.04	73.5	9.11
	6	37.3	4.75	44.7	4.92	51.7	5.75	55.4	6.59	60.2	7.09	68.4	8.17	73.5	9.27
	8	37.3	4.82	44.7	5.02	51.7	5.88	55.4	6.71	60.2	7.21	68.4	8.32	73.5	9.35
	10	37.3	4.92	44.7	5.14	51.7	5.99	55.4	6.83	60.2	7.38	68.4	8.42	73.5	9.50
	12	37.3	5.02	44.7	5.24	51.7	6.11	55.4	6.95	60.2	7.51	68.4	8.58	73.5	9.68
	14	37.3	5.12	44.7	5.33	51.7	6.22	55.4	7.18	60.2	7.65	68.4	8.74	73.5	9.85
	16	37.3	5.22	44.7	5.43	51.7	6.36	55.4	7.20	60.2	7.80	68.4	8.92	73.5	10.03
	18	37.3	5.32	44.7	5.55	51.7	6.48	55.4	7.22	60.2	7.96	68.4	9.09	73.5	10.34
	20	37.3	5.44	44.7	5.68	51.7	6.61	55.4	7.69	60.2	8.25	68.4	9.78	73.5	10.83
	21	37.3	5.49	44.7	5.72	51.7	6.73	55.4	8.24	60.2	8.55	68.4	10.13	73.5	11.08
	23	37.3	5.87	44.7	5.96	51.7	7.24	55.4	8.69	60.2	9.17	68.4	10.87	73.5	11.59
	25	37.3	6.29	44.7	6.39	51.7	7.76	55.4	9.33	60.2	9.79	68.4	11.63	73.5	12.10
	27	37.3	6.72	44.7	6.82	51.7	8.31	55.4	9.99	60.2	10.48	68.4	12.45	73.5	12.60
	29	37.3	7.19	44.7	7.28	51.7	8.90	55.4	10.46	60.2	11.20	68.4	13.01	73.5	13.11
	31	37.3	7.69	44.7	7.77	51.7	9.50	55.4	11.15	60.2	11.94	68.4	13.52	73.5	13.64
	33	37.3	8.21	44.7	8.28	51.7	10.16	55.4	11.83	60.2	12.74	68.4	14.05	73.5	14.15
	35	37.3	8.74	44.7	8.82	51.7	10.85	55.4	12.37	60.2	13.58	68.4	14.56	73.5	14.67
	37	37.3	9.32	44.7	9.39	51.7	11.57	55.4	12.93	60.2	14.48	68.4	15.06	73.5	15.18
	39	37.3	9.92	44.7	10.02	51.7	12.33	55.4	13.44	60.2	15.44	68.4	15.59	73.5	15.71
	41	37.3	10.29	44.7	10.48	51.7	12.79	55.4	13.92	60.2	15.51	68.4	15.99	73.5	16.08
43	37.3	10.66	44.7	10.94	51.7	13.26	55.4	14.58	60.2	15.84	68.4	16.19	73.5	16.33	
45	37.3	11.16	44.7	11.50	51.7	13.82	55.4	15.50	60.2	16.28	68.4	17.60	73.5	18.35	
48	37.3	12.87	44.7	14.10	51.7	15.34	55.4	16.58	60.2	17.81	68.4	19.05	73.5	20.29	
50	37.3	14.57	44.7	15.81	51.7	17.05	55.4	18.28	60.2	19.52	68.4	20.76	73.5	22.00	
52	37.3	16.28	44.7	17.52	51.7	18.75	55.4	19.99	60.2	21.23	68.4	22.47	73.5	23.70	
54	37.3	17.99	44.7	19.22	51.7	20.46	55.4	21.70	60.2	22.94	68.4	24.17	73.5	25.41	
60%	-5	31.8	3.57	38.0	3.89	44.2	4.29	47.3	5.49	51.4	5.98	58.5	6.65	62.8	7.63
	-2	31.8	3.62	38.0	3.94	44.2	4.35	47.3	5.56	51.4	6.08	58.5	6.75	62.8	7.68
	0	31.8	3.66	38.0	3.99	44.2	4.42	47.3	5.63	51.4	6.17	58.5	6.85	62.8	7.78
	2	31.8	3.71	38.0	4.04	44.2	4.47	47.3	5.74	51.4	6.26	58.5	6.99	62.8	7.88
	4	31.8	3.75	38.0	4.11	44.2	4.55	47.3	5.81	51.4	6.38	58.5	7.10	62.8	7.99
	6	31.8	3.83	38.0	4.17	44.2	4.64	47.3	5.94	51.4	6.51	58.5	7.24	62.8	8.18
	8	31.8	3.89	38.0	4.26	44.2	4.74	47.3	6.05	51.4	6.64	58.5	7.38	62.8	8.31
	10	31.8	3.97	38.0	4.33	44.2	4.83	47.3	6.23	51.4	6.75	58.5	7.52	62.8	8.29
	12	31.8	4.05	38.0	4.43	44.2	4.92	47.3	6.34	51.4	6.89	58.5	7.66	62.8	8.43
	14	31.8	4.13	38.0	4.52	44.2	5.02	47.3	6.45	51.4	7.00	58.5	7.80	62.8	8.57
	16	31.8	4.21	38.0	4.63	44.2	5.13	47.3	6.56	51.4	7.14	58.5	7.93	62.8	8.73
	18	31.8	4.29	38.0	4.72	44.2	5.22	47.3	6.67	51.4	7.27	58.5	8.07	62.8	8.90
	20	31.8	4.38	38.0	4.89	44.2	5.33	47.3	6.80	51.4	7.33	58.5	8.24	62.8	9.06
	21	31.8	4.42	38.0	5.09	44.2	5.43	47.3	7.30	51.4	7.47	58.5	8.32	62.8	9.26
	23	31.8	4.73	38.0	5.49	44.2	5.84	47.3	7.79	51.4	7.93	58.5	8.65	62.8	9.34
	25	31.8	5.07	38.0	5.92	44.2	6.26	47.3	8.22	51.4	8.46	58.5	9.23	62.8	9.95
	27	31.8	5.42	38.0	6.36	44.2	6.70	47.3	8.62	51.4	9.01	58.5	9.84	62.8	10.61
	29	31.8	5.80	38.0	6.83	44.2	7.17	47.3	8.99	51.4	9.59	58.5	10.50	62.8	11.32
	31	31.8	6.20	38.0	7.33	44.2	7.66	47.3	9.49	51.4	10.19	58.5	11.16	62.8	12.09
	33	31.8	6.62	38.0	7.86	44.2	8.19	47.3	9.89	51.4	10.83	58.5	11.87	62.8	12.87
	35	31.8	7.04	38.0	8.42	44.2	8.75	47.3	9.97	51.4	11.49	58.5	12.65	62.8	13.72
	37	31.8	7.52	38.0	9.01	44.2	9.33	47.3	10.43	51.4	12.20	58.5	13.44	62.8	14.60
	39	31.8	8.00	38.0	9.63	44.2	9.94	47.3	10.83	51.4	12.65	58.5	14.27	62.8	15.54
	41	31.8	8.30	38.0	10.00	44.2	10.32	47.3	11.22	51.4	13.10	58.5	14.94	62.8	16.53
43	31.8	8.60	38.0	10.20	44.2	10.69	47.3	11.75	51.4	13.74	58.5	15.58	62.8	17.28	
45	31.8	9.30	38.0	11.48	44.2	12.14	47.3	12.80	51.4	14.86	58.5	16.28	62.8	18.03	
48	31.8	10.67	38.0	11.97	44.2	13.27	47.3	14.56	51.4	15.86	58.5	17.15	62.8	18.45	
50	31.8	12.05	38.0	13.34	44.2	14.64	47.3	15.94	51.4	17.23	58.5	18.53	62.8	19.83	
52	31.8	13.42	38.0	14.72	44.2	16.02	47.3	17.31	51.4	18.61	58.5	19.91	62.8	21.20	
54	31.8	14.80	38.0	16.10	44.2	17.39	47.3	18.69	51.4	19.99	58.5	21.28	62.8	22.58	

Обозначения:

CR: Индекс установленной мощности;

ТС: Полная производительность (кВт);

PI: Потребляемая мощность (компрессор + двигатель вентилятора наружного блока) (кВт)

Примечание: 1. В серых ячейках указаны расчётные значения.

Продолжение таблицы на следующей странице...

Часть 2 Технические характеристики наружных блоков

Таблица 2-8.6: Таблица холодопроизводительности для блоков производительностью 28 л.с. (продолжение)

CR	Температура наружного воздуха(°C DB)	Температура в помещении (°C DB/WD)													
		20.8/14		23.3/16		25.8/18		27/19		28.2/20		30.7/22		32/24	
		ТС кВт	PI кВт	ТС кВт	PI кВт	ТС кВт	PI кВт	ТС кВт	PI кВт	ТС кВт	PI кВт	ТС кВт	PI кВт	ТС кВт	PI кВт
50%	-5	26.8	2.96	32.0	3.22	37.1	3.55	39.6	4.87	43.0	5.05	48.9	5.75	52.7	6.19
	-2	26.8	3.00	32.0	3.26	37.1	3.60	39.6	4.99	43.0	5.15	48.9	5.82	52.7	6.28
	0	26.8	3.03	32.0	3.30	37.1	3.66	39.6	5.01	43.0	5.20	48.9	5.92	52.7	6.38
	2	26.8	3.07	32.0	3.34	37.1	3.70	39.6	5.03	43.0	5.29	48.9	5.95	52.7	6.51
	4	26.8	3.11	32.0	3.40	37.1	3.77	39.6	5.04	43.0	5.40	48.9	6.09	52.7	6.67
	6	26.8	3.17	32.0	3.45	37.1	3.84	39.6	5.08	43.0	5.50	48.9	6.19	52.7	6.87
	8	26.8	3.22	32.0	3.52	37.1	3.92	39.6	5.10	43.0	5.57	48.9	6.29	52.7	7.09
	10	26.8	3.29	32.0	3.59	37.1	4.00	39.6	5.06	43.0	5.73	48.9	6.45	52.7	7.20
	12	26.8	3.35	32.0	3.67	37.1	4.08	39.6	5.09	43.0	5.85	48.9	6.57	52.7	7.31
	14	26.8	3.42	32.0	3.75	37.1	4.15	39.6	5.11	43.0	5.94	48.9	6.68	52.7	7.46
	16	26.8	3.49	32.0	3.83	37.1	4.25	39.6	5.12	43.0	6.02	48.9	6.80	52.7	7.57
	18	26.8	3.55	32.0	3.91	37.1	4.32	39.6	5.15	43.0	6.14	48.9	6.91	52.7	7.71
	20	26.8	3.63	32.0	4.05	37.1	4.42	39.6	5.39	43.0	6.25	48.9	7.03	52.7	7.86
	21	26.8	3.66	32.0	4.21	37.1	4.49	39.6	5.66	43.0	6.31	48.9	7.11	52.7	7.94
	23	26.8	3.92	32.0	4.55	37.1	4.83	39.6	6.04	43.0	6.42	48.9	7.23	52.7	8.11
	25	26.8	4.20	32.0	4.90	37.1	5.18	39.6	6.43	43.0	6.62	48.9	7.60	52.7	8.66
	27	26.8	4.49	32.0	5.27	37.1	5.55	39.6	6.93	43.0	7.03	48.9	8.09	52.7	9.23
	29	26.8	4.80	32.0	5.66	37.1	5.94	39.6	7.14	43.0	7.48	48.9	8.60	52.7	9.84
	31	26.8	5.13	32.0	6.07	37.1	6.34	39.6	7.61	43.0	7.94	48.9	9.15	52.7	10.47
	33	26.8	5.48	32.0	6.51	37.1	6.79	39.6	8.03	43.0	8.43	48.9	9.72	52.7	11.13
	35	26.8	5.83	32.0	6.97	37.1	7.24	39.6	8.26	43.0	8.92	48.9	10.32	52.7	11.81
37	26.8	6.22	32.0	7.46	37.1	7.72	39.6	8.63	43.0	9.46	48.9	10.95	52.7	12.56	
39	26.8	6.62	32.0	7.97	37.1	8.23	39.6	8.97	43.0	10.04	48.9	11.61	52.7	13.33	
41	26.8	6.87	32.0	8.28	37.1	8.54	39.6	9.29	43.0	10.47	48.9	12.23	52.7	13.95	
43	26.8	7.12	32.0	8.45	37.1	8.85	39.6	9.90	43.0	10.74	48.9	12.85	52.7	14.57	
45	26.8	7.45	32.0	9.51	37.1	10.13	39.6	10.93	43.0	12.00	48.9	14.09	52.7	15.19	
48	26.8	8.75	32.0	9.99	37.1	11.23	39.6	12.47	43.0	13.71	48.9	14.95	52.7	16.19	
50	26.8	10.06	32.0	11.30	37.1	12.54	39.6	13.78	43.0	15.01	48.9	16.25	52.7	17.49	
52	26.8	11.36	32.0	12.60	37.1	13.84	39.6	15.08	43.0	16.32	48.9	17.56	52.7	18.80	
54	26.8	12.67	32.0	13.91	37.1	15.15	39.6	16.39	43.0	17.62	48.9	18.86	52.7	20.10	

Обозначения:

CR: Индекс установленной мощности;

ТС: Полная производительность (кВт);

PI: Потребляемая мощность (компрессор + двигатель вентилятора наружного блока) (кВт)

Примечание: 1. В серых ячейках указаны расчётные значения.

MVS FDC II-S

Таблица 2-8.7: Таблица холодопроизводительности для блоков производительностью 30 л.с.

CR	Температура наружного воздуха (°C DB)	Температура в помещении (°C DB/WD)													
		20.8/14		23.3/16		25.8/18		27/19		28.2/20		30.7/22		32/24	
		ТС	PI	ТС	PI	ТС	PI	ТС	PI	ТС	PI	ТС	PI	ТС	PI
		кВт	кВт	кВт	кВт	кВт	кВт	кВт	кВт	кВт	кВт	кВт	кВт	кВт	
130%	-5	77.0	11.71	93.6	13.13	105.6	14.16	108.6	15.37	116.2	16.40	119.3	17.84	120.3	17.95
	-2	77.0	11.71	93.6	13.41	105.6	14.16	109.5	15.46	116.2	16.40	119.3	18.06	120.3	18.13
	0	77.0	11.92	93.6	13.66	105.6	14.72	109.5	16.34	116.2	17.36	119.3	18.28	120.3	18.37
	2	77.0	12.13	93.6	13.69	105.6	15.26	109.5	17.29	116.2	17.56	119.3	18.42	120.3	18.64
	4	77.0	12.40	93.6	13.98	105.6	15.83	109.5	17.37	116.2	17.78	119.3	18.41	120.3	19.00
	6	77.0	12.64	93.6	14.28	105.6	16.46	109.5	17.52	114.2	18.34	115.9	18.40	120.3	19.14
	8	77.0	12.94	93.6	14.63	105.6	17.34	109.5	18.40	113.0	18.94	114.6	18.49	119.0	19.32
	10	77.0	13.21	93.6	14.98	105.6	18.03	109.5	19.04	111.9	19.07	114.3	19.07	117.5	19.88
	12	77.0	13.44	93.6	15.28	105.6	18.41	108.4	19.26	110.4	19.57	113.3	19.41	116.3	20.01
	14	77.0	13.71	93.6	15.59	104.9	18.49	107.5	19.36	109.0	19.75	112.5	19.74	114.8	20.46
	16	77.0	13.94	93.6	15.94	103.7	19.01	105.6	19.75	107.6	20.15	111.7	20.20	113.7	20.78
	18	77.0	14.21	93.6	16.29	102.2	19.30	103.9	20.00	106.2	20.70	110.9	20.90	112.6	21.09
	20	77.0	14.52	93.6	17.41	101.1	20.31	102.3	21.01	104.9	21.71	110.1	21.90	111.6	22.13
	21	77.0	14.91	93.6	18.07	100.6	20.81	102.6	21.51	103.5	22.21	109.3	22.44	110.5	22.63
	23	77.0	15.99	93.6	19.46	98.7	21.81	100.4	22.51	102.1	23.21	108.5	23.44	109.4	23.68
	25	77.0	17.07	93.6	20.92	97.2	22.82	98.9	23.52	100.7	24.26	107.7	24.49	108.4	24.72
	27	77.0	18.23	93.6	22.47	96.0	23.82	97.5	25.03	99.3	25.26	106.9	25.53	107.3	25.80
	29	77.0	19.47	93.6	24.09	94.4	24.82	96.1	26.38	98.0	26.30	106.1	26.58	106.3	26.84
	31	77.0	20.78	90.4	25.56	93.1	25.87	94.9	27.68	96.6	27.31	105.3	27.62	105.2	27.93
	33	77.0	22.13	88.8	26.56	91.6	26.87	93.2	29.20	95.2	28.35	104.5	28.66	104.1	28.97
	35	77.0	23.60	87.3	27.57	90.3	27.91	91.6	29.68	93.8	29.39	103.7	29.74	103.1	30.05
	37	77.0	25.11	86.1	28.80	88.8	28.96	90.5	29.70	92.4	30.48	102.9	30.82	102.0	31.17
	39	77.0	26.73	84.5	29.95	87.3	30.09	89.1	30.74	91.6	31.52	102.1	31.87	100.9	32.25
	41	77.0	28.13	83.6	31.09	86.4	31.22	87.7	31.78	89.2	32.39	92.0	32.72	99.9	33.13
	43	77.0	29.24	83.0	32.23	85.9	32.33	86.3	33.70	88.2	34.05	90.3	34.34	98.8	34.66
	45	77.0	30.35	82.5	33.67	85.0	34.65	84.9	35.32	87.0	35.67	87.8	35.88	97.7	36.65
	48	77.0	34.39	82.0	35.27	84.1	36.14	83.4	37.02	85.7	37.90	85.4	38.77	96.7	39.65
	50	77.0	38.42	79.5	39.30	82.3	40.18	82.0	41.06	84.2	41.93	80.2	42.81	95.6	43.69
52	77.0	42.46	78.3	43.34	81.2	44.21	80.6	45.09	82.8	45.97	76.4	46.84	94.6	47.72	
54	77.0	46.49	77.0	47.37	80.0	48.25	79.2	49.13	81.4	50.00	72.6	50.88	93.5	51.76	
120%	-5	72.0	11.30	83.5	12.24	97.2	14.16	105.7	15.91	110.7	16.95	113.2	18.41	115.7	18.91
	-2	72.0	11.41	83.5	12.38	97.2	14.32	105.7	16.01	110.7	17.17	113.2	18.57	115.7	18.98
	0	72.0	11.52	83.5	12.47	97.2	14.50	105.7	16.06	110.7	17.33	113.2	18.68	115.7	19.02
	2	72.0	11.55	83.5	12.62	97.2	14.62	105.7	16.23	110.7	17.41	113.2	18.82	115.7	19.06
	4	72.0	11.66	83.5	12.80	97.2	14.85	105.7	16.39	110.7	17.66	113.2	18.87	115.7	19.11
	6	72.0	11.79	83.5	12.91	97.2	15.06	105.7	16.59	110.7	17.86	113.2	19.02	115.7	19.18
	8	72.0	11.89	83.5	13.05	97.2	15.29	105.7	16.83	110.7	18.06	113.2	19.09	115.7	19.27
	10	72.0	12.04	83.5	13.25	97.2	15.44	105.7	17.16	110.7	18.07	113.2	19.15	115.7	19.36
	12	72.0	12.27	83.5	13.52	97.2	15.79	105.7	17.51	109.2	18.15	111.6	19.04	114.1	19.49
	14	72.0	12.50	83.5	13.83	97.2	16.14	105.7	17.90	107.6	18.28	110.4	19.34	112.9	19.73
	16	72.0	12.73	83.5	14.13	97.2	16.49	105.5	18.15	106.4	18.57	108.9	19.67	111.3	20.03
	18	72.0	12.96	83.5	14.44	97.2	17.10	103.4	18.71	104.8	19.07	107.3	20.14	110.1	20.33
	20	72.0	13.23	83.5	15.06	97.2	18.57	102.3	19.71	103.6	20.07	106.1	21.14	108.6	21.33
	21	72.0	13.35	83.5	15.64	97.2	19.30	100.5	20.93	102.7	20.58	105.5	21.64	107.9	21.87
	23	72.0	14.27	83.5	16.87	97.2	20.81	98.4	22.60	101.4	21.58	103.9	22.68	106.4	22.87
	25	72.0	15.24	83.5	18.15	95.6	21.81	97.2	23.57	99.9	22.58	102.7	23.68	105.1	23.92
	27	72.0	16.28	83.5	19.50	94.4	22.78	95.7	25.11	98.6	23.63	101.1	24.73	103.6	24.96
	29	72.0	17.36	83.5	20.92	92.8	23.78	94.1	26.17	97.1	24.63	99.6	25.77	102.4	26.00
	31	72.0	18.52	83.5	22.43	91.4	24.82	92.8	27.46	95.9	25.67	98.3	26.81	100.8	27.08
	33	72.0	19.71	83.5	24.01	90.0	25.82	91.4	28.63	94.3	26.67	96.8	27.85	99.3	28.12
	35	72.0	20.99	83.5	25.71	88.6	26.82	89.7	29.01	93.1	27.71	95.5	28.89	98.0	29.20
	37	72.0	22.33	83.5	27.48	87.3	27.87	88.6	29.18	90.6	29.36	94.0	29.94	96.5	30.28
	39	72.0	23.76	83.2	29.10	85.7	28.87	87.0	29.35	89.1	29.80	92.8	31.01	95.2	31.32
	41	72.0	25.07	82.6	29.32	85.0	29.89	86.3	30.73	87.5	30.84	90.3	32.05	92.6	32.39
	43	72.0	26.18	82.1	29.54	84.4	30.73	85.6	31.42	86.8	31.88	88.7	33.10	91.1	33.46
	45	72.0	27.28	81.7	29.83	83.6	31.34	84.7	32.52	86.1	32.92	86.9	34.15	90.5	34.52
	48	72.0	31.28	81.2	32.15	82.8	33.02	84.0	33.89	85.4	34.76	85.3	35.63	89.4	36.50
	50	72.0	35.28	80.7	36.16	81.9	37.03	83.0	37.90	84.0	38.77	83.4	39.64	87.4	40.51
52	72.0	39.29	80.2	40.16	81.0	41.03	82.1	41.90	83.0	42.77	81.6	43.64	86.0	44.51	
54	72.0	43.29	79.7	44.16	80.2	45.03	81.2	45.90	81.9	46.77	79.8	47.64	84.5	48.51	

Обозначения:

- CR: Индекс установленной мощности;
- ТС: Полная производительность (кВт);
- PI: Потребляемая мощность (компрессор + двигатель вентилятора наружного блока) (кВт)

Примечание: 1. В серых ячейках указаны расчётные значения.

Продолжение таблицы на следующей странице...

Таблица 2-8.7: Таблица холодопроизводительности для блоков производительностью 30 л.с. (продолжение)

CR	Температура наружного воздуха (°C DB)	Температура в помещении (°C DB/WD)													
		20.8/14		23.3/16		25.8/18		27/19		28.2/20		30.7/22		32/24	
		ТС	PI	ТС	PI	ТС	PI	ТС	PI	ТС	PI	ТС	PI	ТС	PI
		кВт	кВт	кВт	кВт	кВт	кВт	кВт	кВт	кВт	кВт	кВт	кВт	кВт	кВт
110%	-5	66.4	9.87	76.8	11.14	92.9	13.23	95.9	14.88	103.3	16.37	111.0	17.02	113.5	18.14
	-2	66.4	10.07	76.8	11.30	92.9	13.35	95.9	15.04	103.3	16.50	111.0	17.19	113.5	18.24
	0	66.4	10.17	76.8	11.37	92.9	13.47	95.9	15.14	103.3	16.69	111.0	17.37	113.5	18.46
	2	66.4	10.39	76.8	11.49	92.9	13.70	95.9	15.31	103.3	16.87	111.0	17.63	113.5	18.69
	4	66.4	10.60	76.8	11.63	92.9	13.84	95.9	15.52	103.3	17.14	111.0	17.88	113.5	18.86
	6	66.4	10.70	76.8	11.78	92.9	13.99	95.9	15.78	103.3	17.34	111.0	18.07	113.5	19.15
	8	66.4	10.80	76.8	11.99	92.9	14.17	95.9	15.95	103.3	17.54	111.0	18.20	113.5	19.35
	10	66.4	10.92	76.8	12.16	92.9	14.39	95.9	16.24	103.3	17.84	111.0	18.33	113.5	19.52
	12	66.4	11.16	76.8	12.44	92.9	14.70	95.9	16.59	103.3	18.19	109.8	18.61	112.0	19.77
	14	66.4	11.35	76.8	12.67	92.9	15.01	95.9	16.89	103.3	18.54	108.2	18.77	110.7	19.91
	16	66.4	11.54	76.8	12.94	92.9	15.31	95.9	17.24	103.3	18.92	107.0	19.00	109.2	20.13
	18	66.4	11.78	76.8	13.21	92.9	15.66	95.9	17.74	103.3	19.85	105.5	20.00	107.9	20.77
	20	66.4	12.01	76.8	13.52	92.9	16.66	95.9	19.13	101.7	20.85	104.2	21.00	106.4	21.77
	21	66.4	12.12	76.8	13.94	92.9	17.32	95.9	20.63	101.1	21.35	103.3	21.51	105.8	22.28
	23	66.4	12.70	76.8	15.02	92.9	18.67	95.9	21.96	99.6	22.32	102.1	22.54	104.2	23.32
	25	66.4	13.55	76.8	16.14	92.9	20.06	95.9	23.43	98.3	23.32	100.5	23.55	103.0	24.32
	27	66.4	14.44	76.8	17.34	92.9	21.57	94.7	24.57	96.8	24.33	99.3	24.56	101.4	25.36
	29	66.4	15.40	76.8	18.58	92.9	23.15	92.9	25.99	95.6	25.37	97.7	25.60	100.2	26.41
	31	66.4	16.41	76.8	19.89	92.9	24.81	91.2	27.43	94.0	26.37	96.5	26.60	98.6	27.45
	33	66.4	17.45	76.8	21.28	92.9	26.24	90.6	28.49	92.8	27.37	94.9	27.65	97.4	28.49
	35	66.4	18.57	76.8	22.74	87.9	27.24	88.2	28.84	91.2	28.42	93.4	28.69	95.9	29.53
	37	66.4	20.33	76.8	24.29	85.7	28.29	87.2	28.98	89.7	29.42	92.2	29.73	94.3	30.58
	39	66.4	22.07	76.8	25.95	84.2	29.29	85.6	30.02	88.1	30.46	90.6	30.77	93.1	31.66
	41	66.4	23.80	76.8	26.17	82.7	29.51	84.8	30.24	86.7	30.68	87.7	31.13	90.3	31.87
43	66.4	25.53	76.8	26.52	81.1	29.72	83.8	30.45	85.2	30.90	87.0	31.95	89.0	32.52	
45	66.4	26.98	76.8	27.46	79.6	30.33	82.4	31.09	83.8	31.52	84.7	32.65	87.0	33.60	
48	66.4	30.96	76.8	31.83	78.0	32.69	81.2	33.56	82.3	34.42	83.7	35.29	85.1	36.15	
50	66.4	34.94	75.0	35.81	76.5	36.67	80.0	37.54	80.9	38.40	81.9	39.27	83.2	40.13	
52	66.4	38.92	73.3	39.79	74.9	40.65	78.8	41.52	79.4	42.38	80.2	43.25	81.3	44.11	
54	66.4	42.90	71.6	43.77	73.4	44.63	77.6	45.50	77.9	46.36	78.6	47.23	79.5	48.09	
100%	-5	59.6	10.14	70.0	11.05	83.8	12.18	85.0	14.30	92.2	13.97	105.9	15.47	109.2	17.05
	-2	59.6	10.28	70.0	11.19	83.8	12.43	85.0	14.41	92.2	14.17	105.9	15.67	109.2	17.17
	0	59.6	10.40	70.0	11.33	83.8	12.64	85.0	14.63	92.2	14.31	105.9	15.95	109.2	17.37
	2	59.6	10.55	70.0	11.47	83.8	12.92	85.0	14.77	92.2	14.48	105.9	16.20	109.2	17.65
	4	59.6	10.65	70.0	11.67	83.8	13.09	85.0	14.98	92.2	14.67	105.9	16.37	109.2	17.85
	6	59.6	10.88	70.0	11.84	83.8	13.32	85.0	15.30	92.2	14.90	105.9	16.63	109.2	18.13
	8	59.6	11.05	70.0	12.09	83.8	13.56	85.0	15.58	92.2	15.16	105.9	16.91	109.2	18.44
	10	59.6	11.27	70.0	12.31	83.8	13.78	85.0	15.82	92.2	15.45	105.9	17.22	109.2	18.71
	12	59.6	11.50	70.0	12.58	83.8	14.30	85.0	16.14	92.2	15.76	105.9	17.56	107.6	18.86
	14	59.6	11.73	70.0	12.85	83.8	14.97	85.0	17.16	92.2	16.06	105.9	17.94	106.4	19.10
	16	59.6	11.96	70.0	13.15	83.8	15.33	85.0	17.60	92.2	16.41	102.8	18.17	104.9	19.33
	18	59.6	12.18	70.0	13.42	83.8	15.92	85.0	18.29	92.2	16.75	101.6	18.82	103.7	19.82
	20	59.6	12.45	70.0	13.88	83.8	17.25	85.0	19.53	92.2	18.01	100.1	19.77	102.2	20.81
	21	59.6	12.57	70.0	14.45	83.8	18.47	85.0	20.72	92.2	18.66	99.5	20.27	101.6	21.31
	23	59.6	13.45	70.0	15.60	83.8	19.87	85.0	22.15	92.2	20.07	98.2	21.26	100.1	22.30
	25	59.6	14.40	70.0	16.82	83.8	21.44	85.0	23.26	92.2	21.56	96.7	22.26	98.8	23.30
	27	59.6	15.39	70.0	18.08	83.8	22.71	85.0	24.66	92.2	23.13	95.2	23.25	97.3	24.33
	29	59.6	16.46	70.0	19.41	83.8	24.41	85.0	25.39	91.9	24.62	94.0	25.13	96.1	25.32
	31	59.6	17.61	70.0	20.83	83.8	26.11	85.0	25.85	90.6	25.61	92.5	26.03	94.6	26.35
	33	59.6	18.79	70.0	22.32	83.8	27.35	85.0	26.58	89.1	26.60	91.3	26.99	93.4	27.38
	35	59.6	20.01	70.0	23.92	83.8	27.91	85.0	28.33	87.6	28.38	89.7	28.66	91.9	28.94
	37	59.6	21.35	70.0	25.60	83.8	28.11	83.9	29.62	86.7	30.04	88.5	30.42	90.3	30.82
	39	59.6	22.72	70.0	27.36	83.8	28.62	82.8	30.77	85.5	31.29	87.0	31.91	89.1	32.17
	41	59.6	23.57	70.0	28.42	83.8	29.04	81.8	31.87	84.4	32.53	83.8	32.84	87.9	33.18
43	59.6	24.42	70.0	28.98	83.8	30.01	81.5	33.39	83.2	33.92	84.3	34.50	84.6	34.76	
45	59.6	25.56	70.0	29.78	83.8	31.89	81.0	35.51	82.0	37.47	83.6	39.35	83.3	40.11	
48	59.6	29.47	70.0	31.73	83.8	34.00	80.0	38.25	80.8	40.51	81.7	42.78	82.0	45.05	
50	59.6	33.38	70.0	35.64	83.8	37.91	79.3	40.17	79.6	42.44	80.4	44.71	80.8	46.97	
52	59.6	37.29	70.0	39.55	83.8	41.82	78.6	44.08	78.4	46.35	79.2	48.62	79.6	50.88	
54	59.6	41.19	70.0	43.46	83.8	45.73	77.8	47.99	77.3	50.26	77.9	52.53	78.3	54.79	

Обозначения:

CR: Индекс установленной мощности;

ТС: Полная производительность (кВт);

PI: Потребляемая мощность (компрессор + двигатель вентилятора наружного блока) (кВт)

Примечание: 1. В серых ячейках указаны расчётные значения.

Продолжение таблицы на следующей странице...

MVS FDC II-S

Таблица 2-8.7: Таблица холодопроизводительности для блоков производительностью 30 л.с. (продолжение)

CR	Температура наружного воздуха (°C DB)	Температура в помещении (°C DB/WD)													
		20.8/14		23.3/16		25.8/18		27/19		28.2/20		30.7/22		32/24	
		ТС	PI	ТС	PI	ТС	PI	ТС	PI	ТС	PI	ТС	PI	ТС	PI
		кВт	кВт	кВт	кВт	кВт	кВт	кВт	кВт	кВт	кВт	кВт	кВт	кВт	кВт
90%	-5	51.8	8.11	61.8	8.84	71.9	9.75	76.8	11.44	83.2	11.17	94.7	12.37	101.7	13.64
	-2	51.8	8.23	61.8	8.95	71.9	9.94	76.8	11.53	83.2	11.33	94.7	12.53	101.7	13.73
	0	51.8	8.32	61.8	9.07	71.9	10.11	76.8	11.71	83.2	11.45	94.7	12.76	101.7	13.89
	2	51.8	8.44	61.8	9.18	71.9	10.34	76.8	11.81	83.2	11.58	94.7	12.96	101.7	14.12
	4	51.8	8.52	61.8	9.34	71.9	10.47	76.8	11.99	83.2	11.74	94.7	13.10	101.7	14.28
	6	51.8	8.70	61.8	9.47	71.9	10.65	76.8	12.24	83.2	11.92	94.7	13.30	101.7	14.50
	8	51.8	8.84	61.8	9.67	71.9	10.85	76.8	12.46	83.2	12.13	94.7	13.53	101.7	14.75
	10	51.8	9.02	61.8	9.85	71.9	11.02	76.8	12.66	83.2	12.36	94.7	13.77	101.7	14.97
	12	51.8	9.20	61.8	10.06	71.9	11.44	76.8	12.91	83.2	12.61	94.7	14.05	101.7	15.09
	14	51.8	9.38	61.8	10.28	71.9	11.98	76.8	13.73	83.2	12.85	94.7	14.35	101.7	15.28
	16	51.8	9.56	61.8	10.52	71.9	12.27	76.8	14.08	83.2	13.13	94.7	14.54	101.7	15.46
	18	51.8	9.75	61.8	10.74	71.9	12.73	76.8	14.63	83.2	13.40	94.7	15.06	101.7	15.86
	20	51.8	9.96	61.8	11.10	71.9	13.80	76.8	15.63	83.2	14.41	94.7	15.82	101.7	16.65
	21	51.8	10.05	61.8	11.56	71.9	14.78	76.8	16.58	83.2	14.93	94.7	16.22	101.7	17.05
	23	51.8	10.76	61.8	12.48	71.9	15.90	76.8	17.72	83.2	16.06	94.7	17.01	101.7	17.84
	25	51.8	11.52	61.8	13.45	71.9	17.15	76.8	18.61	83.2	17.25	94.7	17.80	101.7	18.64
	27	51.8	12.31	61.8	14.46	71.9	18.17	76.8	19.73	83.2	18.50	94.7	18.60	101.7	19.46
	29	51.8	13.17	61.8	15.53	71.9	19.53	76.8	20.31	83.2	19.69	94.7	20.10	101.7	20.25
	31	51.8	14.09	61.8	16.66	71.9	20.88	76.8	20.68	83.2	20.49	94.7	20.83	101.7	21.08
	33	51.8	15.03	61.8	17.85	71.9	21.88	76.8	21.27	83.2	21.28	94.7	21.59	101.7	21.90
	35	51.8	16.01	61.8	19.14	71.9	22.33	76.8	22.66	83.2	22.70	94.7	22.93	101.7	23.15
	37	51.8	17.08	61.8	20.48	71.9	22.49	76.8	23.68	83.2	24.03	94.7	24.33	101.7	24.66
	39	51.8	18.18	61.8	21.88	71.9	22.89	76.8	24.06	83.2	25.03	94.7	25.53	101.7	25.74
41	51.8	18.86	61.8	22.73	71.9	23.23	76.8	24.51	83.2	26.02	94.7	26.27	101.7	26.55	
43	51.8	19.54	61.8	23.18	71.9	24.01	76.8	24.98	83.2	27.13	94.7	27.60	101.7	27.81	
45	51.8	20.45	61.8	23.83	71.9	25.51	76.8	25.42	83.2	27.71	94.7	28.76	101.7	29.37	
48	51.8	23.57	61.8	24.71	71.9	25.84	76.8	26.97	83.2	28.11	94.7	29.24	101.7	30.37	
50	51.8	26.70	61.8	27.83	71.9	28.97	76.8	30.10	83.2	31.23	94.7	32.37	101.7	33.50	
52	51.8	29.83	61.8	30.96	71.9	32.09	76.8	33.23	83.2	34.36	94.7	35.49	101.7	36.63	
54	51.8	32.96	61.8	34.09	71.9	35.22	76.8	36.36	83.2	37.49	94.7	38.62	101.7	39.75	
80%	-5	46.1	6.21	55.0	6.42	63.8	7.46	68.4	6.96	74.4	9.26	84.6	10.65	90.7	12.19
	-2	46.1	6.30	55.0	6.49	63.8	7.56	68.4	6.97	74.4	9.37	84.6	10.75	90.7	12.31
	0	46.1	6.37	55.0	6.57	63.8	7.68	68.4	7.13	74.4	9.49	84.6	10.87	90.7	12.41
	2	46.1	6.46	55.0	6.66	63.8	7.77	68.4	7.44	74.4	9.64	84.6	11.10	90.7	12.59
	4	46.1	6.52	55.0	6.76	63.8	7.91	68.4	7.46	74.4	9.76	84.6	11.27	90.7	12.78
	6	46.1	6.66	55.0	6.90	63.8	8.06	68.4	7.67	74.4	9.94	84.6	11.45	90.7	12.99
	8	46.1	6.76	55.0	7.04	63.8	8.24	68.4	7.96	74.4	10.11	84.6	11.66	90.7	13.11
	10	46.1	6.90	55.0	7.20	63.8	8.40	68.4	8.04	74.4	10.34	84.6	11.81	90.7	13.32
	12	46.1	7.04	55.0	7.34	63.8	8.56	68.4	8.25	74.4	10.53	84.6	12.04	90.7	13.57
	14	46.1	7.18	55.0	7.48	63.8	8.73	68.4	8.41	74.4	10.72	84.6	12.26	90.7	13.81
	16	46.1	7.32	55.0	7.61	63.8	8.92	68.4	8.62	74.4	10.94	84.6	12.50	90.7	14.06
	18	46.1	7.46	55.0	7.78	63.8	9.08	68.4	8.92	74.4	11.16	84.6	12.75	90.7	14.50
	20	46.1	7.62	55.0	7.96	63.8	9.27	68.4	9.71	74.4	11.57	84.6	13.70	90.7	15.18
	21	46.1	7.69	55.0	8.02	63.8	9.44	68.4	10.43	74.4	11.98	84.6	14.20	90.7	15.54
	23	46.1	8.23	55.0	8.35	63.8	10.15	68.4	11.31	74.4	12.86	84.6	15.24	90.7	16.25
	25	46.1	8.82	55.0	8.95	63.8	10.89	68.4	12.17	74.4	13.73	84.6	16.30	90.7	16.96
	27	46.1	9.42	55.0	9.56	63.8	11.65	68.4	13.33	74.4	14.69	84.6	17.45	90.7	17.67
	29	46.1	10.08	55.0	10.21	63.8	12.47	68.4	13.90	74.4	15.70	84.6	18.25	90.7	18.38
	31	46.1	10.78	55.0	10.90	63.8	13.32	68.4	14.86	74.4	16.74	84.6	18.96	90.7	19.12
	33	46.1	11.50	55.0	11.61	63.8	14.25	68.4	15.83	74.4	17.86	84.6	19.70	90.7	19.83
	35	46.1	12.25	55.0	12.37	63.8	15.21	68.4	17.34	74.4	19.04	84.6	20.41	90.7	20.57
	37	46.1	13.07	55.0	13.17	63.8	16.22	68.4	18.13	74.4	20.30	84.6	21.12	90.7	21.28
	39	46.1	13.91	55.0	14.04	63.8	17.29	68.4	18.84	74.4	21.65	84.6	21.86	90.7	22.02
41	46.1	14.43	55.0	14.69	63.8	17.94	68.4	19.51	74.4	21.74	84.6	22.41	90.7	22.54	
43	46.1	14.95	55.0	15.34	63.8	18.59	68.4	20.44	74.4	22.21	84.6	22.71	90.7	22.89	
45	46.1	15.65	55.0	16.12	63.8	19.37	68.4	21.74	74.4	22.82	84.6	22.94	90.7	23.20	
48	46.1	18.04	55.0	19.43	63.8	20.81	68.4	22.20	74.4	23.59	84.6	24.98	90.7	26.36	
50	46.1	20.43	55.0	21.82	63.8	23.21	68.4	24.59	74.4	25.98	84.6	27.37	90.7	28.76	
52	46.1	22.83	55.0	24.21	63.8	25.60	68.4	26.99	74.4	28.38	84.6	29.76	90.7	31.15	
54	46.1	25.22	55.0	26.61	63.8	27.99	68.4	29.38	74.4	30.77	84.6	32.16	90.7	33.54	

Обозначения:

CR: Индекс установленной мощности;

ТС: Полная производительность (кВт);

PI: Потребляемая мощность (компрессор + двигатель вентилятора наружного блока) (кВт)

Примечание: 1. В серых ячейках указаны расчётные значения.

Продолжение таблицы на следующей странице...

Таблица 2-8.7: Таблица холодопроизводительности для блоков производительностью 30 л.с. (продолжение)

CR	Температура наружного воздуха (°C DB)	Температура в помещении (°C DB/WD)													
		20.8/14		23.3/16		25.8/18		27/19		28.2/20		30.7/22		32/24	
		ТС	PI	ТС	PI	ТС	PI	ТС	PI	ТС	PI	ТС	PI	ТС	PI
		кВт	кВт	кВт	кВт	кВт	кВт	кВт	кВт	кВт	кВт	кВт	кВт	кВт	кВт
70%	-5	40.4	5.03	48.4	5.20	56.0	6.05	60.0	6.98	65.2	7.51	74.0	8.63	79.6	9.89
	-2	40.4	5.10	48.4	5.26	56.0	6.13	60.0	7.01	65.2	7.60	74.0	8.72	79.6	9.98
	0	40.4	5.16	48.4	5.33	56.0	6.23	60.0	7.05	65.2	7.70	74.0	8.82	79.6	10.06
	2	40.4	5.24	48.4	5.40	56.0	6.30	60.0	7.24	65.2	7.82	74.0	9.00	79.6	10.21
	4	40.4	5.29	48.4	5.48	56.0	6.41	60.0	7.36	65.2	7.92	74.0	9.14	79.6	10.36
	6	40.4	5.40	48.4	5.60	56.0	6.54	60.0	7.50	65.2	8.06	74.0	9.28	79.6	10.53
	8	40.4	5.48	48.4	5.71	56.0	6.68	60.0	7.62	65.2	8.20	74.0	9.45	79.6	10.63
	10	40.4	5.59	48.4	5.84	56.0	6.81	60.0	7.76	65.2	8.38	74.0	9.58	79.6	10.80
	12	40.4	5.71	48.4	5.95	56.0	6.94	60.0	7.90	65.2	8.54	74.0	9.76	79.6	11.00
	14	40.4	5.82	48.4	6.06	56.0	7.08	60.0	8.16	65.2	8.70	74.0	9.94	79.6	11.20
	16	40.4	5.93	48.4	6.17	56.0	7.23	60.0	8.19	65.2	8.87	74.0	10.14	79.6	11.40
	18	40.4	6.05	48.4	6.31	56.0	7.36	60.0	8.21	65.2	9.05	74.0	10.34	79.6	11.76
	20	40.4	6.18	48.4	6.46	56.0	7.52	60.0	8.74	65.2	9.38	74.0	11.11	79.6	12.31
	21	40.4	6.24	48.4	6.51	56.0	7.65	60.0	9.36	65.2	9.72	74.0	11.51	79.6	12.60
	23	40.4	6.67	48.4	6.77	56.0	8.23	60.0	9.88	65.2	10.42	74.0	12.35	79.6	13.18
	25	40.4	7.15	48.4	7.26	56.0	8.83	60.0	10.60	65.2	11.14	74.0	13.22	79.6	13.75
	27	40.4	7.64	48.4	7.75	56.0	9.45	60.0	11.36	65.2	11.91	74.0	14.15	79.6	14.33
	29	40.4	8.17	48.4	8.28	56.0	10.11	60.0	11.89	65.2	12.73	74.0	14.80	79.6	14.91
	31	40.4	8.74	48.4	8.84	56.0	10.80	60.0	12.68	65.2	13.58	74.0	15.37	79.6	15.50
	33	40.4	9.33	48.4	9.41	56.0	11.56	60.0	13.45	65.2	14.48	74.0	15.97	79.6	16.08
	35	40.4	9.93	48.4	10.03	56.0	12.33	60.0	14.06	65.2	15.44	74.0	16.55	79.6	16.68
	37	40.4	10.60	48.4	10.68	56.0	13.15	60.0	14.70	65.2	16.46	74.0	17.12	79.6	17.26
	39	40.4	11.28	48.4	11.39	56.0	14.02	60.0	15.27	65.2	17.55	74.0	17.72	79.6	17.86
	41	40.4	11.70	48.4	11.91	56.0	14.55	60.0	15.82	65.2	17.63	74.0	18.17	79.6	18.28
43	40.4	12.12	48.4	12.44	56.0	15.07	60.0	16.57	65.2	18.01	74.0	18.41	79.6	18.56	
45	40.4	12.69	48.4	13.07	56.0	15.71	60.0	17.63	65.2	18.50	74.0	20.01	79.6	20.87	
48	40.4	14.63	48.4	16.03	56.0	17.44	60.0	18.85	65.2	20.25	74.0	21.66	79.6	23.06	
50	40.4	16.57	48.4	17.97	56.0	19.38	60.0	20.79	65.2	22.19	74.0	23.60	79.6	25.01	
52	40.4	18.51	48.4	19.91	56.0	21.32	60.0	22.73	65.2	24.13	74.0	25.54	79.6	26.95	
54	40.4	20.45	48.4	21.86	56.0	23.26	60.0	24.67	65.2	26.07	74.0	27.48	79.6	28.89	
60%	-5	34.5	4.06	41.2	4.42	47.9	4.88	51.3	6.24	55.6	6.80	63.4	7.56	68.0	8.67
	-2	34.5	4.12	41.2	4.48	47.9	4.94	51.3	6.33	55.6	6.92	63.4	7.68	68.0	8.73
	0	34.5	4.16	41.2	4.54	47.9	5.02	51.3	6.41	55.6	7.01	63.4	7.79	68.0	8.84
	2	34.5	4.22	41.2	4.59	47.9	5.08	51.3	6.53	55.6	7.11	63.4	7.95	68.0	8.96
	4	34.5	4.26	41.2	4.67	47.9	5.17	51.3	6.61	55.6	7.26	63.4	8.07	68.0	9.08
	6	34.5	4.35	41.2	4.74	47.9	5.27	51.3	6.76	55.6	7.40	63.4	8.23	68.0	9.30
	8	34.5	4.42	41.2	4.84	47.9	5.39	51.3	6.88	55.6	7.55	63.4	8.39	68.0	9.44
	10	34.5	4.51	41.2	4.93	47.9	5.49	51.3	7.08	55.6	7.67	63.4	8.55	68.0	9.43
	12	34.5	4.60	41.2	5.03	47.9	5.60	51.3	7.20	55.6	7.83	63.4	8.71	68.0	9.58
	14	34.5	4.69	41.2	5.14	47.9	5.70	51.3	7.33	55.6	7.96	63.4	8.86	68.0	9.74
	16	34.5	4.78	41.2	5.26	47.9	5.83	51.3	7.45	55.6	8.11	63.4	9.02	68.0	9.93
	18	34.5	4.88	41.2	5.37	47.9	5.94	51.3	7.58	55.6	8.27	63.4	9.18	68.0	10.12
	20	34.5	4.98	41.2	5.55	47.9	6.06	51.3	7.74	55.6	8.33	63.4	9.36	68.0	10.30
	21	34.5	5.03	41.2	5.78	47.9	6.17	51.3	8.29	55.6	8.49	63.4	9.46	68.0	10.52
	23	34.5	5.38	41.2	6.24	47.9	6.63	51.3	8.86	55.6	9.02	63.4	9.83	68.0	10.62
	25	34.5	5.76	41.2	6.73	47.9	7.12	51.3	9.35	55.6	9.62	63.4	10.49	68.0	11.31
	27	34.5	6.16	41.2	7.23	47.9	7.62	51.3	9.80	55.6	10.24	63.4	11.18	68.0	12.06
	29	34.5	6.59	41.2	7.77	47.9	8.15	51.3	10.22	55.6	10.90	63.4	11.93	68.0	12.87
	31	34.5	7.05	41.2	8.33	47.9	8.71	51.3	10.79	55.6	11.59	63.4	12.68	68.0	13.75
	33	34.5	7.52	41.2	8.93	47.9	9.32	51.3	11.24	55.6	12.31	63.4	13.50	68.0	14.63
	35	34.5	8.01	41.2	9.57	47.9	9.94	51.3	11.34	55.6	13.06	63.4	14.38	68.0	15.60
	37	34.5	8.54	41.2	10.24	47.9	10.60	51.3	11.85	55.6	13.88	63.4	15.28	68.0	16.60
	39	34.5	9.09	41.2	10.95	47.9	11.30	51.3	12.31	55.6	14.39	63.4	16.22	68.0	17.66
	41	34.5	9.43	41.2	11.37	47.9	11.73	51.3	12.76	55.6	14.89	63.4	16.99	68.0	18.79
43	34.5	9.77	41.2	11.60	47.9	12.15	51.3	13.36	55.6	15.62	63.4	17.71	68.0	19.64	
45	34.5	10.57	41.2	13.05	47.9	13.80	51.3	14.55	55.6	16.89	63.4	18.50	68.0	20.49	
48	34.5	12.13	41.2	13.61	47.9	15.08	51.3	16.55	55.6	18.03	63.4	19.50	68.0	20.98	
50	34.5	13.70	41.2	15.17	47.9	16.64	51.3	18.12	55.6	19.59	63.4	21.07	68.0	22.54	
52	34.5	15.26	41.2	16.74	47.9	18.21	51.3	19.68	55.6	21.16	63.4	22.63	68.0	24.11	
54	34.5	16.83	41.2	18.30	47.9	19.77	51.3	21.25	55.6	22.72	63.4	24.20	68.0	25.67	

Обозначения:

- CR: Индекс установленной мощности;
- ТС: Полная производительность (кВт);
- PI: Потребляемая мощность (компрессор + двигатель вентилятора наружного блока) (кВт)

Примечание: 1. В серых ячейках указаны расчётные значения.

Продолжение таблицы на следующей странице...

MVS FDC II-S

Таблица 2-8.7: Таблица холодопроизводительности для блоков производительностью 30 л.с. (продолжение)

CR	Температура наружного воздуха (°C DB)	Температура в помещении (°C DB/WD)													
		20.8/14		23.3/16		25.8/18		27/19		28.2/20		30.7/22		32/24	
		ТС кВт	PI кВт	ТС кВт	PI кВт	ТС кВт	PI кВт	ТС кВт	PI кВт	ТС кВт	PI кВт	ТС кВт	PI кВт	ТС кВт	PI кВт
50%	-5	29.0	3.36	34.6	3.66	40.2	4.04	42.9	5.54	46.5	5.75	52.9	6.53	57.0	7.04
	-2	29.0	3.41	34.6	3.71	40.2	4.09	42.9	5.67	46.5	5.85	52.9	6.62	57.0	7.14
	0	29.0	3.45	34.6	3.76	40.2	4.16	42.9	5.70	46.5	5.91	52.9	6.73	57.0	7.26
	2	29.0	3.50	34.6	3.80	40.2	4.21	42.9	5.71	46.5	6.02	52.9	6.76	57.0	7.40
	4	29.0	3.53	34.6	3.87	40.2	4.28	42.9	5.73	46.5	6.14	52.9	6.93	57.0	7.59
	6	29.0	3.61	34.6	3.92	40.2	4.37	42.9	5.78	46.5	6.25	52.9	7.03	57.0	7.81
	8	29.0	3.66	34.6	4.01	40.2	4.46	42.9	5.80	46.5	6.34	52.9	7.15	57.0	8.06
	10	29.0	3.73	34.6	4.08	40.2	4.55	42.9	5.75	46.5	6.52	52.9	7.34	57.0	8.18
	12	29.0	3.81	34.6	4.17	40.2	4.64	42.9	5.78	46.5	6.65	52.9	7.46	57.0	8.31
	14	29.0	3.89	34.6	4.26	40.2	4.72	42.9	5.81	46.5	6.75	52.9	7.60	57.0	8.48
	16	29.0	3.96	34.6	4.36	40.2	4.83	42.9	5.82	46.5	6.85	52.9	7.73	57.0	8.61
	18	29.0	4.04	34.6	4.45	40.2	4.92	42.9	5.85	46.5	6.98	52.9	7.86	57.0	8.77
	20	29.0	4.13	34.6	4.60	40.2	5.02	42.9	6.12	46.5	7.11	52.9	7.99	57.0	8.93
	21	29.0	4.16	34.6	4.79	40.2	5.11	42.9	6.44	46.5	7.17	52.9	8.08	57.0	9.03
	23	29.0	4.46	34.6	5.17	40.2	5.49	42.9	6.87	46.5	7.30	52.9	8.21	57.0	9.23
	25	29.0	4.77	34.6	5.57	40.2	5.89	42.9	7.31	46.5	7.53	52.9	8.64	57.0	9.84
	27	29.0	5.10	34.6	5.99	40.2	6.31	42.9	7.88	46.5	7.99	52.9	9.19	57.0	10.50
	29	29.0	5.46	34.6	6.43	40.2	6.75	42.9	8.12	46.5	8.51	52.9	9.78	57.0	11.18
	31	29.0	5.83	34.6	6.90	40.2	7.21	42.9	8.65	46.5	9.03	52.9	10.40	57.0	11.90
	33	29.0	6.23	34.6	7.40	40.2	7.71	42.9	9.12	46.5	9.58	52.9	11.05	57.0	12.65
	35	29.0	6.63	34.6	7.93	40.2	8.23	42.9	9.39	46.5	10.14	52.9	11.74	57.0	13.43
37	29.0	7.08	34.6	8.48	40.2	8.78	42.9	9.82	46.5	10.76	52.9	12.45	57.0	14.28	
39	29.0	7.53	34.6	9.07	40.2	9.36	42.9	10.20	46.5	11.41	52.9	13.20	57.0	15.16	
41	29.0	7.81	34.6	9.42	40.2	9.71	42.9	10.56	46.5	11.90	52.9	13.91	57.0	15.86	
43	29.0	8.09	34.6	9.60	40.2	10.06	42.9	11.25	46.5	12.21	52.9	14.61	57.0	16.57	
45	29.0	8.47	34.6	10.81	40.2	11.52	42.9	12.42	46.5	13.64	52.9	16.02	57.0	17.27	
48	29.0	9.95	34.6	11.36	40.2	12.77	42.9	14.18	46.5	15.59	52.9	16.99	57.0	18.40	
50	29.0	11.44	34.6	12.84	40.2	14.25	42.9	15.66	46.5	17.07	52.9	18.48	57.0	19.89	
52	29.0	12.92	34.6	14.33	40.2	15.74	42.9	17.14	46.5	18.55	52.9	19.96	57.0	21.37	
54	29.0	14.40	34.6	15.81	40.2	17.22	42.9	18.63	46.5	20.04	52.9	21.44	57.0	22.85	

Обозначения:

CR: Индекс установленной мощности;

ТС: Полная производительность (кВт);

PI: Потребляемая мощность (компрессор + двигатель вентилятора наружного блока) (кВт)

Примечание: 1. В серых ячейках указаны расчётные значения.

Таблица 2-8.8: Таблица холодопроизводительности для блоков производительностью 32 л.с.

CR	Температура наружного воздуха (°C DB)	Температура в помещении (°C DB/WD)													
		20.8/14		23.3/16		25.8/18		27/19		28.2/20		30.7/22		32/24	
		ТС кВт	PI кВт	ТС кВт	PI кВт	ТС кВт	PI кВт	ТС кВт	PI кВт	ТС кВт	PI кВт	ТС кВт	PI кВт	ТС кВт	PI кВт
130%	-5	81.5	13.29	99.1	14.89	111.8	16.06	115.0	17.43	123.0	18.61	126.4	20.23	127.3	20.36
	-2	81.5	13.29	99.1	15.21	111.8	16.06	116.0	17.54	123.0	18.61	126.4	20.49	127.3	20.57
	0	81.5	13.52	99.1	15.49	111.8	16.70	116.0	18.54	123.0	19.69	126.4	20.74	127.3	20.84
	2	81.5	13.76	99.1	15.53	111.8	17.32	116.0	19.62	123.0	19.92	126.4	20.89	127.3	21.15
	4	81.5	14.07	99.1	15.86	111.8	17.96	116.0	19.70	123.0	20.18	126.4	20.88	127.3	21.55
	6	81.5	14.34	99.1	16.20	111.8	18.67	116.0	19.87	120.9	20.80	122.7	20.88	127.3	21.71
	8	81.5	14.68	99.1	16.60	111.8	19.67	116.0	20.88	119.7	21.48	121.4	20.98	126.0	21.92
	10	81.5	14.99	99.1	16.99	111.8	20.45	116.0	21.60	118.5	21.63	121.0	21.63	124.4	22.56
	12	81.5	15.25	99.1	17.34	111.8	20.89	114.7	21.85	116.9	22.20	120.0	22.02	123.1	22.70
	14	81.5	15.56	99.1	17.69	111.1	20.98	113.8	21.96	115.4	22.40	119.2	22.39	121.5	23.21
	16	81.5	15.82	99.1	18.09	109.8	21.56	111.8	22.40	113.9	22.86	118.3	22.92	120.4	23.58
	18	81.5	16.12	99.1	18.48	108.2	21.90	110.0	22.69	112.5	23.49	117.5	23.71	119.3	23.93
	20	81.5	16.48	99.1	19.75	107.0	23.04	108.4	23.83	111.0	24.63	116.6	24.85	118.1	25.11
	21	81.5	16.91	99.1	20.50	106.5	23.61	108.7	24.40	109.6	25.20	115.8	25.46	117.0	25.68
	23	81.5	18.14	99.1	22.07	104.6	24.75	106.3	25.54	108.1	26.34	114.9	26.60	115.9	26.86
	25	81.5	19.37	99.1	23.74	102.9	25.88	104.7	26.68	106.6	27.52	114.1	27.78	114.8	28.04
	27	81.5	20.68	99.1	25.49	101.6	27.02	103.2	28.40	105.2	28.66	113.2	28.97	113.6	29.27
	29	81.5	22.09	99.1	27.33	100.0	28.16	101.8	29.93	103.7	29.84	112.4	30.15	112.5	30.45
	31	81.5	23.58	95.7	29.00	98.5	29.35	100.5	31.41	102.3	30.98	111.5	31.33	111.4	31.68
	33	81.5	25.11	94.1	30.14	97.0	30.48	98.7	33.12	100.8	32.16	110.7	32.51	110.3	32.87
	35	81.5	26.77	92.4	31.27	95.6	31.67	97.0	33.12	99.3	33.35	109.8	33.74	109.1	34.09
	37	81.5	28.48	91.1	32.68	94.1	32.85	95.9	33.69	97.9	34.57	109.0	34.97	108.0	35.36
	39	81.5	30.32	89.5	33.97	92.4	34.14	94.4	34.87	97.0	35.76	108.1	36.15	106.9	36.59
	41	81.5	31.91	88.6	35.27	91.5	35.42	92.9	36.05	94.4	36.75	97.4	37.13	105.7	37.58
	43	81.5	33.18	87.9	36.57	91.0	37.70	91.4	38.23	93.4	38.63	95.6	38.96	104.6	39.33
	45	81.5	34.44	87.4	38.20	90.0	39.32	89.9	40.07	92.1	40.46	93.0	40.71	103.5	41.58
48	81.5	39.01	86.8	40.01	89.0	41.00	88.3	42.00	90.7	42.99	90.4	43.99	102.4	44.98	
50	81.5	43.59	84.1	44.59	87.2	45.58	86.8	46.58	89.1	47.57	84.9	48.57	101.2	49.56	
52	81.5	48.17	82.9	49.16	85.9	50.16	85.3	51.15	87.6	52.15	80.9	53.14	100.1	54.14	
54	81.5	52.75	81.6	53.74	84.7	54.74	83.8	55.73	86.2	56.73	76.9	57.72	99.0	58.72	
120%	-5	76.2	12.82	88.5	13.88	102.9	16.06	111.9	18.05	117.2	19.23	119.8	20.89	122.5	21.46
	-2	76.2	12.95	88.5	14.05	102.9	16.24	111.9	18.17	117.2	19.48	119.8	21.06	122.5	21.53
	0	76.2	13.07	88.5	14.15	102.9	16.46	111.9	18.22	117.2	19.66	119.8	21.19	122.5	21.58
	2	76.2	13.10	88.5	14.32	102.9	16.59	111.9	18.41	117.2	19.75	119.8	21.36	122.5	21.62
	4	76.2	13.23	88.5	14.52	102.9	16.85	111.9	18.59	117.2	20.03	119.8	21.40	122.5	21.69
	6	76.2	13.37	88.5	14.65	102.9	17.08	111.9	18.83	117.2	20.27	119.8	21.58	122.5	21.75
	8	76.2	13.49	88.5	14.81	102.9	17.34	111.9	19.09	117.2	20.49	119.8	21.66	122.5	21.86
	10	76.2	13.65	88.5	15.03	102.9	17.52	111.9	19.47	117.2	20.50	119.8	21.72	122.5	21.96
	12	76.2	13.92	88.5	15.34	102.9	17.91	111.9	19.87	115.6	20.60	118.2	21.60	120.8	22.11
	14	76.2	14.18	88.5	15.69	102.9	18.31	111.9	20.30	113.9	20.73	116.9	21.94	119.5	22.38
	16	76.2	14.44	88.5	16.03	102.9	18.70	111.7	20.59	112.6	21.06	115.3	22.31	117.9	22.73
	18	76.2	14.70	88.5	16.39	102.9	19.40	109.5	21.22	111.0	21.64	113.6	22.84	116.6	23.06
	20	76.2	15.01	88.5	17.08	102.9	21.07	108.3	22.36	109.7	22.77	112.3	23.98	114.9	24.20
	21	76.2	15.14	88.5	17.74	102.9	21.90	106.4	23.75	108.7	23.34	111.7	24.55	114.3	24.81
	23	76.2	16.19	88.5	19.14	102.9	23.60	104.2	25.63	107.4	24.48	110.0	25.73	112.6	25.95
	25	76.2	17.29	88.5	20.59	101.2	24.74	102.9	26.74	105.8	25.62	108.7	26.87	111.3	27.13
	27	76.2	18.47	88.5	22.12	99.9	25.84	101.3	28.48	104.4	26.80	107.1	28.05	109.7	28.31
	29	76.2	19.69	88.5	23.74	98.3	26.97	99.6	29.69	102.8	27.94	105.4	29.23	108.4	29.50
	31	76.2	21.01	88.5	25.44	96.7	28.16	98.3	31.15	101.5	29.12	104.1	30.41	106.7	30.72
	33	76.2	22.36	88.5	27.24	95.3	29.29	96.7	32.48	99.9	30.26	102.5	31.60	105.1	31.90
	35	76.2	23.81	88.5	29.17	93.8	30.43	95.0	32.91	98.5	31.44	101.2	32.78	103.8	33.13
	37	76.2	25.34	88.5	31.18	92.4	31.61	93.8	33.10	96.0	33.30	99.5	33.96	102.2	34.35
	39	76.2	26.96	88.1	33.02	90.8	32.75	92.2	33.30	94.3	33.80	98.2	35.19	100.8	35.53
	41	76.2	28.45	87.4	33.26	90.0	33.91	91.4	34.86	92.7	34.98	95.6	36.36	98.0	36.75
	43	76.2	29.70	87.0	33.51	89.3	34.86	90.6	35.64	92.0	36.17	93.9	37.55	96.5	37.95
	45	76.2	30.95	86.5	33.84	88.5	35.55	89.7	36.89	91.1	37.35	92.0	38.74	95.8	39.16
48	76.2	35.49	85.9	36.48	87.7	37.46	88.9	38.45	90.4	39.44	90.3	40.43	94.6	41.41	
50	76.2	40.03	85.4	41.02	86.7	42.00	87.8	42.99	88.9	43.98	88.3	44.97	92.6	45.95	
52	76.2	44.57	84.9	45.56	85.8	46.55	86.9	47.53	87.8	48.52	86.4	49.51	91.0	50.50	
54	76.2	49.11	84.4	50.10	84.9	51.09	86.0	52.08	86.8	53.06	84.5	54.05	89.5	55.04	

Обозначения:
 CR: Индекс установленной мощности;
 ТС: Полная производительность (кВт);
 PI: Потребляемая мощность (компрессор + двигатель вентилятора наружного блока) (кВт)

Примечание: 1. В серых ячейках указаны расчётные значения.

Продолжение таблицы на следующей странице...

MVS FDC II-S

Таблица 2-8.8: Таблица холодопроизводительности для блоков производительностью 32 л.с. (продолжение)

CR	Температура наружного воздуха (°C DB)	Температура в помещении (°C DB/WD)													
		20.8/14		23.3/16		25.8/18		27/19		28.2/20		30.7/22		32/24	
		ТС	PI	ТС	PI	ТС	PI	ТС	PI	ТС	PI	ТС	PI	ТС	PI
		кВт	кВт	кВт	кВт	кВт	кВт	кВт	кВт	кВт	кВт	кВт	кВт	кВт	кВт
110%	-5	70.3	11.20	81.3	12.64	98.3	15.01	101.5	16.88	109.4	18.57	117.6	19.31	120.2	20.58
	-2	70.3	11.42	81.3	12.82	98.3	15.15	101.5	17.06	109.4	18.72	117.6	19.51	120.2	20.69
	0	70.3	11.53	81.3	12.90	98.3	15.28	101.5	17.18	109.4	18.93	117.6	19.71	120.2	20.94
	2	70.3	11.79	81.3	13.04	98.3	15.54	101.5	17.37	109.4	19.14	117.6	20.00	120.2	21.20
	4	70.3	12.02	81.3	13.20	98.3	15.70	101.5	17.60	109.4	19.44	117.6	20.29	120.2	21.40
	6	70.3	12.14	81.3	13.37	98.3	15.87	101.5	17.90	109.4	19.67	117.6	20.50	120.2	21.73
	8	70.3	12.25	81.3	13.60	98.3	16.07	101.5	18.09	109.4	19.90	117.6	20.65	120.2	21.95
	10	70.3	12.39	81.3	13.80	98.3	16.32	101.5	18.42	109.4	20.24	117.6	20.80	120.2	22.14
	12	70.3	12.66	81.3	14.11	98.3	16.67	101.5	18.82	109.4	20.63	116.3	21.11	118.5	22.43
	14	70.3	12.88	81.3	14.37	98.3	17.02	101.5	19.17	109.4	21.03	114.6	21.29	117.2	22.59
	16	70.3	13.10	81.3	14.68	98.3	17.37	101.5	19.56	109.4	21.46	113.3	21.55	115.6	22.84
	18	70.3	13.36	81.3	14.99	98.3	17.77	101.5	20.13	109.4	22.52	111.7	22.69	114.3	23.56
	20	70.3	13.62	81.3	15.34	98.3	18.90	101.5	21.71	107.7	23.66	110.4	23.83	112.7	24.70
	21	70.3	13.75	81.3	15.82	98.3	19.65	101.5	23.41	107.1	24.22	109.4	24.40	112.0	25.27
	23	70.3	14.41	81.3	17.04	98.3	21.19	101.5	24.92	105.4	25.32	108.1	25.58	110.4	26.46
	25	70.3	15.37	81.3	18.31	98.3	22.76	101.5	26.58	104.1	26.46	106.4	26.72	109.0	27.59
	27	70.3	16.38	81.3	19.67	98.3	24.47	100.2	27.87	102.5	27.60	105.1	27.86	107.4	28.78
	29	70.3	17.47	81.3	21.07	98.3	26.26	98.4	29.49	101.2	28.78	103.5	29.04	106.1	29.96
	31	70.3	18.61	81.3	22.56	98.3	28.15	96.5	31.12	99.5	29.92	102.2	30.18	104.5	31.14
	33	70.3	19.80	81.3	24.14	98.3	29.77	96.0	32.32	98.2	31.06	100.5	31.36	103.1	32.33
	35	70.3	21.07	81.3	25.80	93.0	30.91	93.4	32.72	96.6	32.24	98.9	32.55	101.5	33.51
	37	70.3	23.06	81.3	27.56	90.8	32.09	92.4	32.88	95.0	33.38	97.6	33.73	99.9	34.69
	39	70.3	25.03	81.3	29.44	89.2	33.23	90.6	34.06	93.3	34.56	95.9	34.91	98.6	35.92
	41	70.3	27.00	81.3	29.69	87.5	33.47	89.8	34.31	91.8	34.81	92.9	35.32	95.6	36.16
	43	70.3	28.97	81.3	30.08	85.9	33.72	88.8	34.55	90.2	35.05	92.1	36.24	94.2	36.90
45	70.3	30.61	81.3	31.15	84.2	34.41	87.2	35.27	88.7	35.76	89.7	37.04	92.1	38.12	
48	70.3	35.12	81.3	36.11	82.6	37.09	86.0	38.07	87.2	39.05	88.7	40.03	90.1	41.01	
50	70.3	39.64	79.5	40.62	81.0	41.60	84.7	42.58	85.6	43.57	86.7	44.55	88.1	45.53	
52	70.3	44.16	77.6	45.14	79.3	46.12	83.4	47.10	84.1	48.08	84.9	49.06	86.1	50.04	
54	70.3	48.67	75.8	49.65	77.7	50.63	82.2	51.62	82.5	52.60	83.2	53.58	84.1	54.56	
100%	-5	63.1	11.51	74.1	12.53	88.7	13.82	90.0	16.22	97.6	15.85	112.2	17.55	115.6	19.35
	-2	63.1	11.67	74.1	12.70	88.7	14.10	90.0	16.35	97.6	16.07	112.2	17.77	115.6	19.48
	0	63.1	11.80	74.1	12.86	88.7	14.34	90.0	16.60	97.6	16.23	112.2	18.09	115.6	19.70
	2	63.1	11.97	74.1	13.02	88.7	14.66	90.0	16.75	97.6	16.42	112.2	18.38	115.6	20.02
	4	63.1	12.08	74.1	13.24	88.7	14.85	90.0	17.00	97.6	16.65	112.2	18.58	115.6	20.25
	6	63.1	12.34	74.1	13.43	88.7	15.11	90.0	17.36	97.6	16.91	112.2	18.87	115.6	20.57
	8	63.1	12.53	74.1	13.72	88.7	15.39	90.0	17.67	97.6	17.19	112.2	19.19	115.6	20.92
	10	63.1	12.79	74.1	13.97	88.7	15.63	90.0	17.95	97.6	17.53	112.2	19.53	115.6	21.23
	12	63.1	13.05	74.1	14.27	88.7	16.22	90.0	18.31	97.6	17.88	112.2	19.92	114.0	21.40
	14	63.1	13.31	74.1	14.58	88.7	16.98	90.0	19.47	97.6	18.22	112.2	20.35	112.7	21.67
	16	63.1	13.56	74.1	14.92	88.7	17.39	90.0	19.96	97.6	18.62	108.8	20.61	111.1	21.93
	18	63.1	13.82	74.1	15.22	88.7	18.06	90.0	20.75	97.6	19.00	107.6	21.35	109.8	22.49
	20	63.1	14.13	74.1	15.75	88.7	19.57	90.0	22.16	97.6	20.43	105.9	22.43	108.2	23.61
	21	63.1	14.26	74.1	16.39	88.7	20.96	90.0	23.51	97.6	21.17	105.3	23.00	107.6	24.18
	23	63.1	15.25	74.1	17.69	88.7	22.55	90.0	25.13	97.6	22.77	104.0	24.12	105.9	25.30
	25	63.1	16.34	74.1	19.08	88.7	24.33	90.0	26.39	97.6	24.46	102.4	25.25	104.7	26.43
	27	63.1	17.46	74.1	20.51	88.7	25.76	90.0	27.97	97.6	26.24	100.8	26.37	103.1	27.60
	29	63.1	18.68	74.1	22.03	88.7	27.70	90.0	28.80	97.3	27.93	99.5	28.51	101.8	28.72
	31	63.1	19.98	74.1	23.63	88.7	29.62	90.0	29.33	96.0	29.05	97.9	29.53	100.2	29.89
	33	63.1	21.32	74.1	25.32	88.7	31.03	90.0	30.16	94.4	30.18	96.6	30.62	98.9	31.06
	35	63.1	22.70	74.1	27.14	88.7	31.66	90.0	32.14	92.8	32.19	95.0	32.51	97.3	32.83
	37	63.1	24.22	74.1	29.04	88.7	31.89	88.8	33.60	91.8	34.08	93.7	34.51	95.7	34.97
	39	63.1	25.78	74.1	31.03	88.7	32.46	87.7	34.91	90.6	35.50	92.1	36.21	94.4	36.50
	41	63.1	26.74	74.1	32.24	88.7	32.95	86.6	36.16	89.3	36.90	88.8	37.25	93.0	37.65
	43	63.1	27.71	74.1	32.87	88.7	34.04	86.3	37.88	88.1	38.48	89.3	39.14	89.6	39.44
45	63.1	28.99	74.1	33.79	88.7	36.18	85.7	40.28	86.8	42.51	88.5	44.64	88.2	45.50	
48	63.1	33.43	74.1	36.00	88.7	38.57	84.7	43.39	85.6	45.96	86.5	48.53	86.9	51.11	
50	63.1	37.86	74.1	40.44	88.7	43.01	84.0	45.58	84.3	48.15	85.2	50.72	85.6	53.29	
52	63.1	42.30	74.1	44.87	88.7	47.44	83.2	50.01	83.1	52.58	83.9	55.16	84.2	57.73	
54	63.1	46.73	74.1	49.31	88.7	51.88	82.4	54.45	81.8	57.02	82.5	59.59	82.9	62.16	

Обозначения:

CR: Индекс установленной мощности;

ТС: Полная производительность (кВт);

PI: Потребляемая мощность (компрессор + двигатель вентилятора наружного блока) (кВт)

Примечание: 1. В серых ячейках указаны расчётные значения.

Продолжение таблицы на следующей странице...

Таблица 2-8.8: Таблица холодопроизводительности для блоков производительностью 32 л.с. (продолжение)

CR	Температура наружного воздуха (°C DB)	Температура в помещении (°C DB/WD)													
		20.8/14		23.3/16		25.8/18		27/19		28.2/20		30.7/22		32/24	
		ТС	PI	ТС	PI	ТС	PI	ТС	PI	ТС	PI	ТС	PI	ТС	PI
		кВт	кВт	кВт	кВт	кВт	кВт	кВт	кВт	кВт	кВт	кВт	кВт	кВт	кВт
90%	-5	54.8	9.20	65.5	10.03	76.1	11.06	81.3	12.98	88.1	12.68	100.3	14.04	107.7	15.48
	-2	54.8	9.33	65.5	10.16	76.1	11.28	81.3	13.08	88.1	12.86	100.3	14.22	107.7	15.58
	0	54.8	9.44	65.5	10.28	76.1	11.47	81.3	13.28	88.1	12.98	100.3	14.48	107.7	15.76
	2	54.8	9.57	65.5	10.41	76.1	11.73	81.3	13.40	88.1	13.14	100.3	14.71	107.7	16.02
	4	54.8	9.67	65.5	10.59	76.1	11.88	81.3	13.60	88.1	13.32	100.3	14.86	107.7	16.20
	6	54.8	9.87	65.5	10.75	76.1	12.08	81.3	13.89	88.1	13.52	100.3	15.09	107.7	16.46
	8	54.8	10.03	65.5	10.97	76.1	12.31	81.3	14.14	88.1	13.76	100.3	15.35	107.7	16.74
	10	54.8	10.23	65.5	11.17	76.1	12.51	81.3	14.36	88.1	14.03	100.3	15.63	107.7	16.99
	12	54.8	10.44	65.5	11.42	76.1	12.98	81.3	14.65	88.1	14.30	100.3	15.94	107.7	17.12
	14	54.8	10.64	65.5	11.66	76.1	13.59	81.3	15.58	88.1	14.58	100.3	16.28	107.7	17.34
	16	54.8	10.85	65.5	11.94	76.1	13.92	81.3	15.97	88.1	14.89	100.3	16.49	107.7	17.54
	18	54.8	11.06	65.5	12.18	76.1	14.45	81.3	16.60	88.1	15.20	100.3	17.08	107.7	17.99
	20	54.8	11.30	65.5	12.60	76.1	15.65	81.3	17.73	88.1	16.35	100.3	17.95	107.7	18.89
	21	54.8	11.41	65.5	13.12	76.1	16.77	81.3	18.81	88.1	16.94	100.3	18.40	107.7	19.34
	23	54.8	12.20	65.5	14.15	76.1	18.04	81.3	20.10	88.1	18.22	100.3	19.30	107.7	20.24
	25	54.8	13.07	65.5	15.26	76.1	19.46	81.3	21.11	88.1	19.57	100.3	20.20	107.7	21.14
	27	54.8	13.97	65.5	16.41	76.1	20.61	81.3	22.38	88.1	20.99	100.3	21.10	107.7	22.08
	29	54.8	14.94	65.5	17.62	76.1	22.16	81.3	23.04	88.1	22.34	100.3	22.81	107.7	22.98
	31	54.8	15.98	65.5	18.90	76.1	23.69	81.3	23.46	88.1	23.24	100.3	23.63	107.7	23.91
	33	54.8	17.05	65.5	20.25	76.1	24.82	81.3	24.13	88.1	24.14	100.3	24.50	107.7	24.85
	35	54.8	18.16	65.5	21.71	76.1	25.33	81.3	25.71	88.1	25.75	100.3	26.01	107.7	26.27
	37	54.8	19.38	65.5	23.23	76.1	25.51	81.3	26.86	88.1	27.27	100.3	27.61	107.7	27.97
	39	54.8	20.62	65.5	24.83	76.1	25.97	81.3	27.30	88.1	28.40	100.3	28.96	107.7	29.20
	41	54.8	21.39	65.5	25.79	76.1	26.36	81.3	27.81	88.1	29.52	100.3	29.80	107.7	30.12
43	54.8	22.17	65.5	26.30	76.1	27.23	81.3	28.34	88.1	30.78	100.3	31.31	107.7	31.55	
45	54.8	23.19	65.5	27.03	76.1	28.94	81.3	28.84	88.1	31.44	100.3	32.63	107.7	33.32	
48	54.8	26.74	65.5	28.03	76.1	29.31	81.3	30.60	88.1	31.89	100.3	33.17	107.7	34.46	
50	54.8	30.29	65.5	31.58	76.1	32.86	81.3	34.15	88.1	35.43	100.3	36.72	107.7	38.00	
52	54.8	33.84	65.5	35.13	76.1	36.41	81.3	37.70	88.1	38.98	100.3	40.27	107.7	41.55	
54	54.8	37.39	65.5	38.67	76.1	39.96	81.3	41.24	88.1	42.53	100.3	43.82	107.7	45.10	
80%	-5	48.8	7.04	58.2	7.28	67.6	8.46	72.5	7.89	78.8	10.51	89.6	12.08	96.1	13.83
	-2	48.8	7.14	58.2	7.36	67.6	8.58	72.5	7.91	78.8	10.63	89.6	12.20	96.1	13.97
	0	48.8	7.22	58.2	7.46	67.6	8.72	72.5	8.09	78.8	10.77	89.6	12.34	96.1	14.08
	2	48.8	7.33	58.2	7.56	67.6	8.81	72.5	8.44	78.8	10.94	89.6	12.59	96.1	14.28
	4	48.8	7.40	58.2	7.67	67.6	8.97	72.5	8.46	78.8	11.08	89.6	12.79	96.1	14.49
	6	48.8	7.56	58.2	7.83	67.6	9.15	72.5	8.70	78.8	11.27	89.6	12.99	96.1	14.74
	8	48.8	7.67	58.2	7.99	67.6	9.35	72.5	9.03	78.8	11.47	89.6	13.23	96.1	14.88
	10	48.8	7.83	58.2	8.17	67.6	9.53	72.5	9.13	78.8	11.73	89.6	13.40	96.1	15.11
	12	48.8	7.99	58.2	8.33	67.6	9.71	72.5	9.36	78.8	11.95	89.6	13.66	96.1	15.39
	14	48.8	8.15	58.2	8.48	67.6	9.90	72.5	9.54	78.8	12.17	89.6	13.90	96.1	15.67
	16	48.8	8.30	58.2	8.64	67.6	10.12	72.5	9.78	78.8	12.41	89.6	14.18	96.1	15.95
	18	48.8	8.46	58.2	8.82	67.6	10.30	72.5	10.12	78.8	12.66	89.6	14.46	96.1	16.45
	20	48.8	8.65	58.2	9.04	67.6	10.52	72.5	11.01	78.8	13.13	89.6	15.55	96.1	17.22
	21	48.8	8.73	58.2	9.10	67.6	10.71	72.5	11.84	78.8	13.59	89.6	16.11	96.1	17.63
	23	48.8	9.34	58.2	9.48	67.6	11.51	72.5	12.83	78.8	14.59	89.6	17.29	96.1	18.43
	25	48.8	10.00	58.2	10.16	67.6	12.35	72.5	13.80	78.8	15.58	89.6	18.50	96.1	19.24
	27	48.8	10.69	58.2	10.84	67.6	13.22	72.5	15.13	78.8	16.67	89.6	19.80	96.1	20.05
	29	48.8	11.43	58.2	11.59	67.6	14.15	72.5	15.76	78.8	17.81	89.6	20.70	96.1	20.85
	31	48.8	12.23	58.2	12.36	67.6	15.11	72.5	16.85	78.8	18.99	89.6	21.51	96.1	21.69
	33	48.8	13.05	58.2	13.17	67.6	16.17	72.5	17.95	78.8	20.27	89.6	22.34	96.1	22.50
	35	48.8	13.90	58.2	14.04	67.6	17.25	72.5	19.68	78.8	21.60	89.6	23.15	96.1	23.34
	37	48.8	14.83	58.2	14.94	67.6	18.40	72.5	20.57	78.8	23.03	89.6	23.96	96.1	24.14
	39	48.8	15.78	58.2	15.93	67.6	19.61	72.5	21.37	78.8	24.56	89.6	24.80	96.1	24.98
	41	48.8	16.37	58.2	16.67	67.6	20.35	72.5	22.14	78.8	24.67	89.6	25.43	96.1	25.57
43	48.8	16.96	58.2	17.41	67.6	21.09	72.5	23.19	78.8	25.19	89.6	25.76	96.1	25.97	
45	48.8	17.75	58.2	18.29	67.6	21.97	72.5	24.66	78.8	25.89	89.6	26.03	96.1	26.32	
48	48.8	20.47	58.2	22.04	67.6	23.61	72.5	25.19	78.8	26.76	89.6	28.34	96.1	29.91	
50	48.8	23.18	58.2	24.75	67.6	26.33	72.5	27.90	78.8	29.48	89.6	31.05	96.1	32.62	
52	48.8	25.90	58.2	27.47	67.6	29.04	72.5	30.62	78.8	32.19	89.6	33.77	96.1	35.34	
54	48.8	28.61	58.2	30.19	67.6	31.76	72.5	33.33	78.8	34.91	89.6	36.48	96.1	38.06	

Обозначения:

CR: Индекс установленной мощности;

ТС: Полная производительность (кВт);

PI: Потребляемая мощность (компрессор + двигатель вентилятора наружного блока) (кВт)

Примечание: 1. В серых ячейках указаны расчётные значения.

Продолжение таблицы на следующей странице...

MVS FDC II-S

Таблица 2-8.8: Таблица холодопроизводительности для блоков производительностью 32 л.с. (продолжение)

CR	Температура наружного воздуха (°C DB)	Температура в помещении (°C DB/WD)													
		20.8/14		23.3/16		25.8/18		27/19		28.2/20		30.7/22		32/24	
		ТС	PI	ТС	PI	ТС	PI	ТС	PI	ТС	PI	ТС	PI	ТС	PI
		кВт	кВт	кВт	кВт	кВт	кВт	кВт	кВт	кВт	кВт	кВт	кВт	кВт	кВт
70%	-5	42.8	5.71	51.2	5.90	59.3	6.86	63.5	7.92	69.0	8.52	78.4	9.80	84.3	11.22
	-2	42.8	5.79	51.2	5.97	59.3	6.96	63.5	7.96	69.0	8.62	78.4	9.89	84.3	11.33
	0	42.8	5.86	51.2	6.05	59.3	7.07	63.5	8.00	69.0	8.73	78.4	10.00	84.3	11.42
	2	42.8	5.94	51.2	6.13	59.3	7.15	63.5	8.22	69.0	8.87	78.4	10.21	84.3	11.58
	4	42.8	6.00	51.2	6.22	59.3	7.28	63.5	8.35	69.0	8.98	78.4	10.37	84.3	11.75
	6	42.8	6.13	51.2	6.35	59.3	7.42	63.5	8.51	69.0	9.14	78.4	10.53	84.3	11.95
	8	42.8	6.22	51.2	6.48	59.3	7.58	63.5	8.65	69.0	9.30	78.4	10.73	84.3	12.06
	10	42.8	6.35	51.2	6.63	59.3	7.73	63.5	8.80	69.0	9.51	78.4	10.86	84.3	12.25
	12	42.8	6.48	51.2	6.75	59.3	7.88	63.5	8.96	69.0	9.69	78.4	11.07	84.3	12.48
	14	42.8	6.61	51.2	6.88	59.3	8.03	63.5	9.26	69.0	9.86	78.4	11.27	84.3	12.71
	16	42.8	6.73	51.2	7.00	59.3	8.20	63.5	9.29	69.0	10.07	78.4	11.50	84.3	12.93
	18	42.8	6.86	51.2	7.16	59.3	8.35	63.5	9.31	69.0	10.27	78.4	11.73	84.3	13.34
	20	42.8	7.01	51.2	7.33	59.3	8.53	63.5	9.92	69.0	10.64	78.4	12.61	84.3	13.97
	21	42.8	7.08	51.2	7.38	59.3	8.68	63.5	10.62	69.0	11.02	78.4	13.06	84.3	14.29
	23	42.8	7.57	51.2	7.68	59.3	9.33	63.5	11.20	69.0	11.83	78.4	14.02	84.3	14.95
	25	42.8	8.11	51.2	8.24	59.3	10.01	63.5	12.03	69.0	12.63	78.4	15.00	84.3	15.60
	27	42.8	8.67	51.2	8.79	59.3	10.72	63.5	12.89	69.0	13.51	78.4	16.05	84.3	16.26
	29	42.8	9.27	51.2	9.39	59.3	11.47	63.5	13.49	69.0	14.45	78.4	16.79	84.3	16.91
	31	42.8	9.92	51.2	10.02	59.3	12.25	63.5	14.38	69.0	15.40	78.4	17.44	84.3	17.59
	33	42.8	10.58	51.2	10.68	59.3	13.11	63.5	15.25	69.0	16.43	78.4	18.12	84.3	18.24
	35	42.8	11.27	51.2	11.38	59.3	13.99	63.5	15.95	69.0	17.51	78.4	18.77	84.3	18.92
	37	42.8	12.02	51.2	12.11	59.3	14.92	63.5	16.68	69.0	18.67	78.4	19.43	84.3	19.58
	39	42.8	12.80	51.2	12.92	59.3	15.90	63.5	17.33	69.0	19.91	78.4	20.11	84.3	20.26
	41	42.8	13.28	51.2	13.52	59.3	16.50	63.5	17.95	69.0	20.00	78.4	20.62	84.3	20.74
43	42.8	13.75	51.2	14.11	59.3	17.10	63.5	18.80	69.0	20.43	78.4	20.89	84.3	21.06	
45	42.8	14.39	51.2	14.83	59.3	17.82	63.5	20.00	69.0	20.99	78.4	22.70	84.3	23.67	
48	42.8	16.59	51.2	18.19	59.3	19.78	63.5	21.38	69.0	22.98	78.4	24.57	84.3	26.17	
50	42.8	18.80	51.2	20.39	59.3	21.99	63.5	23.58	69.0	25.18	78.4	26.77	84.3	28.37	
52	42.8	21.00	51.2	22.59	59.3	24.19	63.5	25.78	69.0	27.38	78.4	28.97	84.3	30.57	
54	42.8	23.20	51.2	24.79	59.3	26.39	63.5	27.99	69.0	29.58	78.4	31.18	84.3	32.77	
60%	-5	36.5	4.60	43.6	5.02	50.7	5.53	54.3	7.07	58.9	7.72	67.1	8.58	72.0	9.84
	-2	36.5	4.67	43.6	5.08	50.7	5.61	54.3	7.18	58.9	7.85	67.1	8.71	72.0	9.90
	0	36.5	4.72	43.6	5.14	50.7	5.70	54.3	7.27	58.9	7.95	67.1	8.84	72.0	10.03
	2	36.5	4.79	43.6	5.21	50.7	5.76	54.3	7.41	58.9	8.07	67.1	9.02	72.0	10.16
	4	36.5	4.84	43.6	5.30	50.7	5.87	54.3	7.50	58.9	8.23	67.1	9.16	72.0	10.30
	6	36.5	4.94	43.6	5.38	50.7	5.98	54.3	7.67	58.9	8.40	67.1	9.34	72.0	10.55
	8	36.5	5.02	43.6	5.49	50.7	6.11	54.3	7.81	58.9	8.56	67.1	9.52	72.0	10.71
	10	36.5	5.12	43.6	5.59	50.7	6.23	54.3	8.03	58.9	8.71	67.1	9.70	72.0	10.70
	12	36.5	5.22	43.6	5.71	50.7	6.35	54.3	8.17	58.9	8.88	67.1	9.88	72.0	10.87
	14	36.5	5.33	43.6	5.83	50.7	6.47	54.3	8.31	58.9	9.03	67.1	10.06	72.0	11.05
	16	36.5	5.43	43.6	5.97	50.7	6.61	54.3	8.46	58.9	9.20	67.1	10.23	72.0	11.26
	18	36.5	5.53	43.6	6.09	50.7	6.73	54.3	8.60	58.9	9.38	67.1	10.41	72.0	11.48
	20	36.5	5.65	43.6	6.30	50.7	6.88	54.3	8.78	58.9	9.45	67.1	10.62	72.0	11.69
	21	36.5	5.71	43.6	6.56	50.7	7.00	54.3	9.41	58.9	9.63	67.1	10.73	72.0	11.94
	23	36.5	6.10	43.6	7.08	50.7	7.53	54.3	10.05	58.9	10.23	67.1	11.16	72.0	12.05
	25	36.5	6.54	43.6	7.64	50.7	8.07	54.3	10.60	58.9	10.91	67.1	11.90	72.0	12.83
	27	36.5	6.99	43.6	8.21	50.7	8.64	54.3	11.12	58.9	11.62	67.1	12.68	72.0	13.68
	29	36.5	7.47	43.6	8.81	50.7	9.25	54.3	11.60	58.9	12.36	67.1	13.54	72.0	14.60
	31	36.5	7.99	43.6	9.46	50.7	9.88	54.3	12.24	58.9	13.15	67.1	14.39	72.0	15.60
	33	36.5	8.53	43.6	10.13	50.7	10.57	54.3	12.76	58.9	13.96	67.1	15.31	72.0	16.59
	35	36.5	9.09	43.6	10.86	50.7	11.28	54.3	12.86	58.9	14.82	67.1	16.31	72.0	17.69
	37	36.5	9.69	43.6	11.62	50.7	12.03	54.3	13.45	58.9	15.74	67.1	17.34	72.0	18.83
	39	36.5	10.32	43.6	12.42	50.7	12.82	54.3	13.97	58.9	16.32	67.1	18.40	72.0	20.04
	41	36.5	10.70	43.6	12.90	50.7	13.30	54.3	14.47	58.9	16.89	67.1	19.27	72.0	21.32
43	36.5	11.09	43.6	13.16	50.7	13.79	54.3	15.16	58.9	17.73	67.1	20.09	72.0	22.28	
45	36.5	11.99	43.6	14.81	50.7	15.65	54.3	16.51	58.9	19.16	67.1	20.99	72.0	23.25	
48	36.5	13.76	43.6	15.44	50.7	17.11	54.3	18.78	58.9	20.45	67.1	22.12	72.0	23.80	
50	36.5	15.54	43.6	17.21	50.7	18.88	54.3	20.56	58.9	22.23	67.1	23.90	72.0	25.57	
52	36.5	17.31	43.6	18.99	50.7	20.66	54.3	22.33	58.9	24.00	67.1	25.67	72.0	27.35	
54	36.5	19.09	43.6	20.76	50.7	22.43	54.3	24.11	58.9	25.78	67.1	27.45	72.0	29.12	

Обозначения:

CR: Индекс установленной мощности;

ТС: Полная производительность (кВт);

PI: Потребляемая мощность (компрессор + двигатель вентилятора наружного блока) (кВт)

Примечание: 1. В серых ячейках указаны расчётные значения.

Продолжение таблицы на следующей странице...

Таблица 2-8.8: Таблица холодопроизводительности для блоков производительностью 32 л.с. (продолжение)

CR	Температура наружного воздуха (°C DB)	Температура в помещении (°CDB/WD)													
		20.8/14		23.3/16		25.8/18		27/19		28.2/20		30.7/22		32/24	
		ТС	PI	ТС	PI	ТС	PI	ТС	PI	ТС	PI	ТС	PI	ТС	PI
		кВт	кВт	кВт	кВт	кВт	кВт	кВт	кВт	кВт	кВт	кВт	кВт	кВт	кВт
50%	-5	30.7	3.81	36.7	4.15	42.5	4.58	45.5	6.28	49.3	6.52	56.0	7.41	60.4	7.99
	-2	30.7	3.87	36.7	4.21	42.5	4.64	45.5	6.44	49.3	6.64	56.0	7.51	60.4	8.09
	0	30.7	3.91	36.7	4.26	42.5	4.72	45.5	6.46	49.3	6.71	56.0	7.64	60.4	8.23
	2	30.7	3.97	36.7	4.31	42.5	4.77	45.5	6.48	49.3	6.83	56.0	7.67	60.4	8.39
	4	30.7	4.00	36.7	4.39	42.5	4.86	45.5	6.50	49.3	6.97	56.0	7.86	60.4	8.61
	6	30.7	4.09	36.7	4.45	42.5	4.95	45.5	6.55	49.3	7.09	56.0	7.98	60.4	8.86
	8	30.7	4.15	36.7	4.55	42.5	5.06	45.5	6.58	49.3	7.19	56.0	8.11	60.4	9.15
	10	30.7	4.24	36.7	4.63	42.5	5.16	45.5	6.52	49.3	7.40	56.0	8.32	60.4	9.28
	12	30.7	4.32	36.7	4.73	42.5	5.26	45.5	6.56	49.3	7.54	56.0	8.47	60.4	9.43
	14	30.7	4.41	36.7	4.83	42.5	5.36	45.5	6.59	49.3	7.66	56.0	8.62	60.4	9.62
	16	30.7	4.49	36.7	4.95	42.5	5.48	45.5	6.60	49.3	7.77	56.0	8.76	60.4	9.76
	18	30.7	4.58	36.7	5.05	42.5	5.58	45.5	6.64	49.3	7.91	56.0	8.91	60.4	9.95
	20	30.7	4.68	36.7	5.22	42.5	5.70	45.5	6.95	49.3	8.06	56.0	9.06	60.4	10.13
	21	30.7	4.72	36.7	5.43	42.5	5.80	45.5	7.30	49.3	8.14	56.0	9.17	60.4	10.24
	23	30.7	5.06	36.7	5.86	42.5	6.23	45.5	7.79	49.3	8.28	56.0	9.32	60.4	10.47
	25	30.7	5.41	36.7	6.32	42.5	6.69	45.5	8.29	49.3	8.54	56.0	9.80	60.4	11.17
	27	30.7	5.79	36.7	6.80	42.5	7.16	45.5	8.94	49.3	9.06	56.0	10.43	60.4	11.91
	29	30.7	6.19	36.7	7.30	42.5	7.66	45.5	9.21	49.3	9.65	56.0	11.10	60.4	12.69
	31	30.7	6.62	36.7	7.83	42.5	8.18	45.5	9.82	49.3	10.24	56.0	11.80	60.4	13.50
	33	30.7	7.06	36.7	8.39	42.5	8.75	45.5	10.35	49.3	10.87	56.0	12.54	60.4	14.35
35	30.7	7.52	36.7	8.99	42.5	9.34	45.5	10.65	49.3	11.50	56.0	13.31	60.4	15.24	
37	30.7	8.03	36.7	9.62	42.5	9.96	45.5	11.14	49.3	12.20	56.0	14.13	60.4	16.20	
39	30.7	8.54	36.7	10.28	42.5	10.62	45.5	11.57	49.3	12.94	56.0	14.98	60.4	17.20	
41	30.7	8.86	36.7	10.68	42.5	11.02	45.5	11.98	49.3	13.50	56.0	15.78	60.4	18.00	
43	30.7	9.18	36.7	10.89	42.5	11.42	45.5	12.77	49.3	13.85	56.0	16.58	60.4	18.80	
45	30.7	9.61	36.7	12.26	42.5	13.07	45.5	14.09	49.3	15.48	56.0	18.17	60.4	19.59	
48	30.7	11.29	36.7	12.89	42.5	14.49	45.5	16.08	49.3	17.68	56.0	19.28	60.4	20.88	
50	30.7	12.97	36.7	14.57	42.5	16.17	45.5	17.77	49.3	19.36	56.0	20.96	60.4	22.56	
52	30.7	14.66	36.7	16.25	42.5	17.85	45.5	19.45	49.3	21.05	56.0	22.65	60.4	24.24	
54	30.7	16.34	36.7	17.94	42.5	19.54	45.5	21.13	49.3	22.73	56.0	24.33	60.4	25.93	

Обозначения:

CR: Индекс установленной мощности;

ТС: Полная производительность (кВт);

PI: Потребляемая мощность (компрессор + двигатель вентилятора наружного блока) (кВт)

Примечание: 1. В серых ячейках указаны расчётные значения.

8.2 Таблицы теплопроизводительности

Таблица 2-8.9: Таблица теплопроизводительности для блоков производительностью 18 л.с.

CR	Температура наружного воздуха (°C DB)		Температура в помещении °C DB											
			16.0		18.0		20.0		21.0		22.0		24.0	
			ТС	PI	ТС	PI	ТС	PI	ТС	PI	ТС	PI	ТС	PI
130%	°C DB	°C WB	кВт	кВт	кВт	кВт	кВт	кВт	кВт	кВт	кВт	кВт	кВт	кВт
	-25	-25.4	40.92	13.31	40.76	13.43	40.60	13.58	40.47	13.66	40.44	13.74	40.22	13.92
	-19.8	-20	41.63	13.33	41.47	13.47	41.31	13.60	41.15	13.69	41.15	13.77	40.99	13.96
	-18.8	-19	41.95	13.35	41.79	13.47	41.63	13.62	41.63	13.70	41.47	13.79	41.31	13.96
	-16.7	-17	42.59	13.36	42.43	13.50	42.27	13.63	42.27	13.72	42.11	13.80	41.95	13.99
	-13.7	-15	43.24	13.38	43.08	13.52	42.92	13.67	42.92	13.75	42.75	13.84	42.59	14.01
	-11.8	-13	43.88	13.42	43.72	13.55	43.56	13.69	43.56	13.77	43.40	13.85	43.40	14.04
	-9.8	-11	44.52	13.43	44.36	13.57	44.20	13.72	44.20	13.79	44.20	13.87	44.04	14.06
	-9.5	-10	44.84	13.45	44.68	13.57	44.68	13.72	44.52	13.80	44.52	13.89	44.36	14.07
	-8.5	-9.1	45.17	13.45	45.00	13.58	44.84	13.74	44.84	13.82	44.84	13.91	44.68	14.09
	-7	-7.6	45.65	13.47	45.49	13.60	45.49	13.75	45.33	13.84	45.33	13.92	45.17	14.11
	-5	-5.6	49.18	14.45	49.02	14.60	48.86	14.75	48.86	14.85	48.70	14.94	48.54	15.12
	-3	-3.7	49.83	15.21	49.67	15.38	49.51	15.54	49.51	15.63	49.34	15.73	49.18	15.93
	0	-0.7	50.79	16.42	50.63	16.61	50.47	16.79	50.47	16.88	50.31	16.98	50.31	17.20
	3	2.2	55.45	16.12	55.45	16.29	55.29	16.47	55.13	16.56	55.13	16.66	54.97	16.47
	5	4.1	69.76	19.94	69.60	19.82	65.90	18.13	63.33	17.30	60.76	16.49	55.77	14.90
	7	6	76.03	18.21	70.88	16.83	65.90	15.48	63.33	14.82	60.76	14.16	55.77	12.89
	9	7.9	76.03	16.63	70.88	15.44	65.90	14.28	63.33	13.72	60.76	13.16	55.77	12.05
11	9.8	76.03	15.24	70.88	14.21	65.90	13.23	63.33	12.76	60.76	12.27	55.77	11.30	
13	11.8	76.03	14.04	70.88	13.16	65.90	12.32	63.33	11.89	60.76	11.47	55.77	10.64	
15	13.7	76.03	13.13	70.88	12.37	65.90	11.62	63.33	11.25	60.76	10.88	55.77	10.15	
120%	-25	-25.4	40.70	13.57	40.54	13.70	40.38	13.85	40.38	13.93	40.21	14.02	40.10	14.21
	-19.8	-20	41.24	13.58	41.08	13.72	40.92	13.87	40.92	13.96	40.76	14.04	40.60	14.23
	-18.8	-19	41.56	13.60	41.40	13.74	41.24	13.89	41.24	13.96	41.08	14.06	40.92	14.23
	-16.7	-17	42.20	13.62	42.04	13.75	41.88	13.91	41.88	13.99	41.72	14.08	41.72	14.26
	-13.7	-15	42.84	13.63	42.68	13.79	42.52	13.94	42.52	14.01	42.52	14.11	42.36	14.28
	-11.8	-13	43.47	13.67	43.31	13.80	43.15	13.96	43.16	14.04	43.16	14.13	43.00	14.31
	-9.8	-11	44.11	13.68	43.95	13.82	43.95	13.97	43.79	14.06	43.79	14.14	43.63	14.33
	-9.5	-10	44.43	13.70	44.27	13.84	44.27	13.99	44.11	14.08	44.11	14.16	43.95	14.35
	-8.5	-9.1	44.75	13.70	44.59	13.85	44.59	14.01	44.43	14.09	44.43	14.18	44.27	14.35
	-7	-7.6	45.23	13.72	45.07	13.87	45.07	14.02	44.91	14.11	44.91	14.19	44.75	14.36
	-5	-5.6	48.75	14.72	48.59	14.88	48.43	15.05	48.43	15.13	48.43	15.22	48.27	15.40
	-3	-3.7	49.39	15.51	49.23	15.68	49.07	15.85	49.07	15.93	48.91	16.03	48.91	16.22
	0	-0.7	50.35	16.75	50.19	16.92	50.03	17.11	50.03	17.21	50.03	17.31	49.87	17.41
	3	2.2	54.98	16.44	54.98	16.59	54.82	16.78	54.66	16.87	54.66	16.75	51.15	15.08
	5	4.1	69.21	19.71	65.05	18.13	60.42	16.61	58.02	15.86	55.78	15.13	51.15	13.70
	7	6	69.69	16.75	65.05	15.49	60.42	14.26	58.02	13.67	55.78	13.09	51.15	11.93
	9	7.9	69.69	15.37	65.05	14.30	60.42	13.26	58.02	12.73	55.78	12.22	51.15	11.22
	11	9.8	69.69	14.18	65.05	13.26	60.42	12.36	58.02	11.91	55.78	11.47	51.15	10.59
13	11.8	69.69	13.12	65.05	12.34	60.42	11.56	58.02	11.17	55.78	10.79	51.15	10.02	
15	13.7	69.69	12.34	65.05	11.66	60.42	10.96	58.02	10.62	55.78	10.30	51.15	9.63	
110%	-25	-25.4	40.20	14.26	40.02	14.42	39.83	14.57	39.89	14.66	39.74	14.75	39.73	14.94
	-19.8	-20	40.79	14.29	40.63	14.45	40.48	14.60	40.48	14.68	40.32	14.78	40.32	14.96
	-18.8	-19	41.11	14.30	40.95	14.45	40.79	14.60	40.79	14.69	40.63	14.78	40.63	14.98
	-16.7	-17	41.75	14.32	41.59	14.48	41.43	14.64	41.43	14.73	41.43	14.82	41.27	14.99
	-13.7	-15	42.38	14.36	42.22	14.50	42.06	14.66	42.06	14.75	42.06	14.83	41.90	15.03
	-11.8	-13	43.02	14.37	42.86	14.53	42.86	14.69	42.70	14.78	42.70	14.87	42.54	15.05
	-9.8	-11	43.65	14.41	43.49	14.55	43.49	14.71	43.33	14.80	43.33	14.89	43.17	15.08
	-9.5	-10	43.97	14.41	43.97	14.57	43.81	14.73	43.65	14.82	43.65	14.91	43.49	15.08
	-8.5	-9.1	44.29	14.43	44.13	14.57	44.13	14.75	43.97	14.82	43.97	14.91	43.81	15.10
	-7	-7.6	44.76	14.45	44.60	14.59	44.60	14.76	44.44	14.83	44.44	14.92	44.29	15.12
	-5	-5.6	48.25	15.51	48.10	15.67	47.94	15.82	47.94	15.91	47.94	16.00	46.51	14.99
	-3	-3.7	48.89	16.32	48.73	16.50	48.57	16.67	48.57	16.76	48.57	16.85	46.51	15.51
	0	-0.7	49.84	17.63	49.68	17.80	49.68	18.00	49.52	18.11	49.52	18.09	46.51	16.28
	3	2.2	54.44	17.29	54.44	17.47	54.29	17.24	52.86	16.44	50.79	15.67	46.51	14.13
	5	4.1	63.49	18.44	59.21	16.99	55.08	15.59	52.86	16.67	50.79	14.23	46.51	12.92
	7	6	63.49	15.77	59.21	14.62	55.08	13.49	52.86	12.94	50.79	12.39	46.51	11.33
	9	7.9	63.49	14.59	59.21	13.58	55.08	12.61	52.86	12.13	50.79	11.65	46.51	10.73
	11	9.8	63.49	13.54	59.21	12.68	55.08	11.83	52.86	11.42	50.79	11.00	46.51	10.18
13	11.8	63.49	12.61	59.21	11.86	55.08	11.14	52.86	10.79	50.79	10.41	46.51	9.71	
15	13.7	63.49	11.93	59.21	11.28	55.08	10.63	52.86	10.31	50.79	10.01	46.51	9.37	

Обозначения:

CR: Индекс установленной мощности; ТС: Полная производительность (кВт); PI: Потребляемая мощность (компрессор + двигатель вентилятора наружного блока) (кВт)

Примечание: 1. В серых ячейках указаны расчётные значения.

Продолжение таблицы на следующей странице...

Таблица 2-8.9: Таблица теплопроизводительности для блоков производительностью 18 л.с. (продолжение)

CR	Температура наружного воздуха (°C DB)		Температура в помещении °C DB											
			16.0		18.0		20.0		21.0		22.0		24.0	
	°C DB	°C WB	ТС	PI	ТС	PI	ТС	PI	ТС	PI	ТС	PI	ТС	PI
100%	-25	-25.4	40.63	14.50	40.48	14.64	40.32	14.80	40.32	14.89	40.32	14.98	40.16	15.17
	-19.8	-20	40.95	14.50	40.79	14.66	40.63	14.82	40.63	14.91	40.63	14.99	40.48	15.17
	-18.8	-19	41.59	14.53	41.43	14.69	41.27	14.85	41.27	14.92	41.27	15.01	41.11	15.19
	-16.7	-17	42.22	14.55	42.06	14.71	42.06	14.87	41.90	14.96	41.90	15.05	41.75	14.87
	-13.7	-15	42.86	14.59	42.70	14.73	42.70	14.91	42.54	14.98	42.54	15.06	42.38	14.57
	-11.8	-13	43.49	14.60	43.33	14.76	43.33	14.92	43.17	15.01	43.17	15.08	42.38	14.29
	-9.8	-11	43.81	14.62	43.81	14.78	43.65	14.94	43.65	15.01	43.49	15.10	42.38	14.14
	-9.5	-10	44.13	14.64	43.97	14.78	43.97	14.94	43.81	15.03	43.81	15.12	42.38	14.02
	-8.5	-9.1	44.60	14.66	44.60	14.80	44.44	14.96	44.29	15.05	44.29	15.14	42.38	13.83
	-7	-7.6	48.10	14.68	47.94	14.81	47.94	14.96	47.78	15.59	46.19	14.83	42.38	13.38
	-5	-5.6	48.73	14.69	48.57	14.81	48.57	14.97	48.10	16.13	46.19	15.35	42.38	13.84
	-3	-3.7	49.68	14.71	49.52	14.82	49.52	14.48	48.10	15.17	46.19	16.13	42.38	14.55
	0	-0.7	50.95	14.73	53.81	14.83	50.00	14.08	48.10	15.95	46.19	15.21	42.38	13.67
	3	2.2	54.29	15.65	53.81	14.46	50.00	13.67	48.10	14.68	46.19	14.00	42.38	12.66
	5	4.1	57.62	14.84	53.81	13.76	50.00	13.03	48.10	13.40	46.19	12.80	42.38	11.65
	7	6	57.62	14.03	53.81	13.05	50.00	12.20	48.10	11.72	46.19	11.23	42.38	10.29
	9	7.9	57.62	13.23	53.81	12.36	50.00	11.49	48.10	11.07	46.19	10.64	42.38	9.81
	11	9.8	57.62	12.38	53.81	11.60	50.00	10.86	48.10	10.48	46.19	10.11	42.38	9.39
13	11.8	57.62	11.60	53.81	10.94	50.00	10.29	48.10	9.97	46.19	9.65	42.38	9.02	
15	13.7	57.62	11.03	53.81	10.47	50.00	9.88	48.10	9.60	46.19	9.32	42.38	8.75	
90%	-25	-25.4	39.74	14.70	39.52	14.84	39.40	15.00	39.37	15.30	39.99	15.58	38.10	14.09
	-19.8	-20	40.48	14.73	40.32	14.87	40.16	15.03	40.16	15.12	40.16	15.21	38.10	13.79
	-18.8	-19	40.79	14.75	40.63	14.89	40.48	15.05	40.48	15.14	40.48	15.15	38.10	13.65
	-16.7	-17	41.43	14.76	41.27	14.91	41.27	15.06	41.11	15.15	41.11	14.85	38.10	13.37
	-13.7	-15	42.06	14.78	41.90	14.94	41.90	15.10	41.75	15.17	41.59	14.55	38.10	13.10
	-11.8	-13	42.70	14.82	42.54	14.96	42.54	15.12	42.38	14.98	41.59	14.25	38.10	12.85
	-9.8	-11	43.33	14.83	43.33	14.99	43.17	15.14	43.17	14.68	41.59	13.99	38.10	12.61
	-9.5	-10	43.65	14.85	43.65	14.99	43.49	15.15	43.33	14.53	41.59	13.84	38.10	12.48
	-8.5	-9.1	43.97	14.87	43.81	15.01	43.81	15.12	43.33	14.41	41.59	13.72	38.10	12.38
	-7	-7.6	44.44	14.89	44.44	15.03	44.29	14.91	43.33	14.22	41.59	13.53	38.10	12.20
	-5	-5.6	47.94	14.91	47.78	15.04	45.08	14.39	43.33	13.74	41.59	13.10	38.10	11.85
	-3	-3.7	48.57	14.93	48.41	15.06	45.08	14.89	43.33	14.22	41.59	13.56	38.10	12.25
	0	-0.7	49.52	14.95	48.41	15.08	45.08	15.65	43.33	14.94	41.59	14.25	38.10	12.89
	3	2.2	51.90	14.98	48.41	14.82	45.08	13.60	43.33	13.00	41.59	12.39	38.10	11.25
	5	4.1	51.90	14.60	48.41	13.53	45.08	12.47	43.33	11.93	41.59	11.42	38.10	10.43
	7	6	51.90	12.70	48.41	11.81	45.08	10.94	43.33	10.52	41.59	10.11	38.10	9.28
	9	7.9	51.90	11.92	48.41	11.16	45.08	10.40	43.33	10.03	41.59	9.65	38.10	8.93
	11	9.8	51.90	11.23	48.41	10.56	45.08	9.90	43.33	9.57	41.59	9.25	38.10	8.61
13	11.8	51.90	10.61	48.41	10.03	45.08	9.46	43.33	9.18	41.59	8.89	38.10	8.33	
15	13.7	51.90	10.17	48.41	9.65	45.08	9.14	43.33	8.89	41.59	8.65	38.10	8.13	
80%	-25	-25.4	39.58	14.76	39.42	15.16	40.00	14.76	38.41	14.07	36.98	13.41	33.81	12.10
	-19.8	-20	40.32	14.79	40.16	14.95	40.00	14.44	38.41	13.78	36.98	13.13	33.81	11.86
	-18.8	-19	40.63	14.81	40.48	14.95	40.00	14.30	38.41	13.64	36.98	12.99	33.81	11.73
	-16.7	-17	41.27	14.82	41.11	14.98	40.00	14.00	38.41	13.36	36.98	12.73	33.81	11.49
	-13.7	-15	41.90	14.86	41.75	15.00	40.00	13.72	38.41	13.09	36.98	12.48	33.81	11.28
	-11.8	-13	42.54	14.88	42.38	14.72	40.00	13.44	38.41	12.83	36.98	12.24	33.81	11.07
	-9.8	-11	43.17	14.89	43.02	14.42	40.00	13.20	38.41	12.59	36.98	12.01	33.81	10.86
	-9.5	-10	43.49	14.91	43.02	14.28	40.00	13.06	38.41	12.47	36.98	11.89	33.81	10.76
	-8.5	-9.1	43.81	14.93	43.02	14.16	40.00	12.96	38.41	12.36	36.98	11.79	33.81	10.67
	-7	-7.6	44.29	14.95	43.02	13.95	40.00	12.78	38.41	12.20	36.98	11.63	33.81	10.53
	-5	-5.6	46.19	14.65	43.02	13.50	40.00	12.38	38.41	11.82	36.98	11.30	33.81	10.23
	-3	-3.7	46.19	15.16	43.02	13.97	40.00	12.82	38.41	12.24	36.98	11.68	33.81	10.60
	0	-0.7	46.19	15.92	43.02	14.68	40.00	13.46	38.41	12.87	36.98	12.29	33.81	11.16
	3	2.2	46.19	13.83	43.02	12.76	40.00	11.73	38.41	11.23	36.98	10.74	33.81	9.76
	5	4.1	46.19	12.64	43.02	11.73	40.00	10.84	38.41	10.41	36.98	9.97	33.81	9.13
	7	6	46.19	11.09	43.02	10.35	40.00	9.62	38.41	9.25	36.98	8.90	33.81	8.21
	9	7.9	46.19	10.51	43.02	9.86	40.00	9.22	38.41	8.90	36.98	8.57	33.81	7.96
	11	9.8	46.19	9.99	43.02	9.41	40.00	8.85	38.41	8.57	36.98	8.29	33.81	7.75
13	11.8	46.19	9.53	43.02	9.03	40.00	8.54	38.41	8.29	36.98	8.05	33.81	7.56	
15	13.7	46.19	9.20	43.02	8.75	40.00	8.31	38.41	8.10	36.98	7.87	33.81	7.44	

Обозначения:

CR: Индекс установленной мощности;
 ТС: Полная производительность (кВт);
 PI: Потребляемая мощность (компрессор + двигатель вентилятора наружного блока) (кВт)

Примечание: 1. В серых ячейках указаны расчётные значения.

Продолжение таблицы на следующей странице...

Dantex MVS FDC II-S серия. Техническая инструкция

MVS FDC II-S

Таблица 2-8.9: Таблица теплопроизводительности для блоков производительностью 18 л.с. (продолжение)

CR	Температура наружного воздуха (°C DB)		Температура в помещении °C DB											
			16.0		18.0		20.0		21.0		22.0		24.0	
			ТС	PI	ТС	PI	ТС	PI	ТС	PI	ТС	PI	ТС	PI
°C DB	°C WB	кВт	кВт	кВт	кВт	кВт	кВт	кВт	кВт	кВт	кВт	кВт	кВт	
70%	-25	-25.4	40.06	15.11	37.62	13.90	35.08	12.73	33.65	12.16	32.38	11.60	29.68	10.50
	-19.8	-20	40.00	14.80	37.62	13.61	35.08	12.48	33.65	11.92	32.38	11.37	29.68	10.29
	-18.8	-19	40.32	14.64	37.62	13.47	35.08	12.34	33.65	11.79	32.38	11.26	29.68	10.20
	-16.7	-17	40.32	14.34	37.62	13.21	35.08	12.11	33.65	11.56	32.38	11.03	29.68	10.01
	-13.7	-15	40.32	14.06	37.62	12.94	35.08	11.86	33.65	11.35	32.38	10.82	29.68	9.81
	-11.8	-13	40.32	13.77	37.62	12.70	35.08	11.65	33.65	11.12	32.38	10.63	29.68	9.64
	-9.8	-11	40.32	13.51	37.62	12.45	35.08	11.42	33.65	10.93	32.38	10.43	29.68	9.46
	-9.5	-10	40.32	13.38	37.62	12.34	35.08	11.32	33.65	10.82	32.38	10.33	29.68	9.39
	-8.5	-9.1	40.32	13.26	37.62	12.24	35.08	11.23	33.65	10.73	32.38	10.26	29.68	9.30
	-7	-7.6	40.32	13.08	37.62	12.06	35.08	11.07	33.65	10.59	32.38	10.11	29.68	9.18
	-5	-5.6	40.32	12.68	37.62	11.70	35.08	10.77	33.65	10.31	32.38	9.85	29.68	8.96
	-3	-3.7	40.32	13.12	37.62	12.11	35.08	11.14	33.65	10.66	32.38	10.20	29.68	9.28
	0	-0.7	40.32	13.79	37.62	12.75	35.08	11.72	33.65	11.23	32.38	10.73	29.68	9.78
	3	2.2	40.32	12.01	37.62	11.12	35.08	10.26	33.65	9.83	32.38	9.41	29.68	8.59
	5	4.1	40.32	11.09	37.62	10.33	35.08	9.57	33.65	9.19	32.38	8.82	29.68	8.10
	7	6	40.32	9.83	37.62	9.19	35.08	8.58	33.65	8.26	32.38	7.96	29.68	7.36
	9	7.9	40.32	9.41	37.62	8.84	35.08	8.29	33.65	8.00	32.38	7.74	29.68	7.21
11	9.8	40.32	9.04	37.62	8.54	35.08	8.04	33.65	7.82	32.38	7.57	29.68	7.09	
13	11.8	40.32	8.70	37.62	8.27	35.08	7.83	33.65	7.62	32.38	7.41	29.68	6.98	
15	13.7	40.32	8.47	37.62	8.08	35.08	7.71	33.65	7.51	32.38	7.32	29.68	6.95	
60%	-25	-25.4	34.60	12.59	32.38	11.60	30.00	10.66	28.89	10.19	27.62	9.74	25.40	8.86
	-19.8	-20	34.60	12.32	32.38	11.37	30.00	10.45	28.89	9.99	27.62	9.55	25.40	8.68
	-18.8	-19	34.60	12.20	32.38	11.26	30.00	10.34	28.89	9.90	27.62	9.46	25.40	8.61
	-16.7	-17	34.60	11.95	32.38	11.03	30.00	10.15	28.89	9.71	27.62	9.28	25.40	8.45
	-13.7	-15	34.60	11.72	32.38	10.82	30.00	9.95	28.89	9.53	27.62	9.12	25.40	8.29
	-11.8	-13	34.60	11.49	32.38	10.63	30.00	9.78	28.89	9.35	27.62	8.95	25.40	8.15
	-9.8	-11	34.60	11.28	32.38	10.43	30.00	9.60	28.89	9.19	27.62	8.79	25.40	8.01
	-9.5	-10	34.60	11.17	32.38	10.33	30.00	9.51	28.89	9.11	27.62	8.72	25.40	7.94
	-8.5	-9.1	34.60	11.10	32.38	10.26	30.00	9.44	28.89	9.04	27.62	8.65	25.40	7.89
	-7	-7.6	34.60	10.93	32.38	10.11	30.00	9.32	28.89	8.93	27.62	8.54	25.40	7.78
	-5	-5.6	34.60	10.63	32.38	9.85	30.00	9.09	28.89	8.72	27.62	8.35	25.40	7.62
	-3	-3.7	34.60	11.02	32.38	10.20	30.00	9.41	28.89	9.04	27.62	8.65	25.40	7.90
	0	-0.7	34.60	11.58	32.38	10.73	30.00	9.92	28.89	9.51	27.62	9.11	25.40	8.33
	3	2.2	34.60	10.13	32.38	9.41	30.00	8.70	28.89	8.36	27.62	8.01	25.40	7.34
	5	4.1	34.60	9.46	32.38	8.82	30.00	8.20	28.89	7.90	27.62	7.60	25.40	7.00
	7	6	34.60	8.49	32.38	7.96	30.00	7.44	28.89	7.18	27.62	6.93	25.40	6.44
	9	7.9	34.60	8.22	32.38	7.74	30.00	7.28	28.89	7.05	27.62	6.84	25.40	6.38
11	9.8	34.60	7.97	32.38	7.57	30.00	7.16	28.89	6.95	27.62	6.75	25.40	6.35	
13	11.8	34.60	7.78	32.38	7.41	30.00	7.05	28.89	6.86	27.62	6.68	25.40	6.33	
15	13.7	34.60	7.66	32.38	7.32	30.00	7.00	28.89	6.84	27.62	6.68	25.40	6.35	
50%	-25	-25.4	28.89	10.17	26.98	9.43	25.08	8.69	23.97	9.10	23.02	7.98	21.11	7.30
	-19.8	-20	28.89	9.99	26.98	9.26	25.08	8.54	23.97	8.20	23.02	7.85	21.11	7.18
	-18.8	-19	28.89	9.90	26.98	9.18	25.08	8.47	23.97	9.88	23.02	7.78	21.11	7.11
	-16.7	-17	28.89	9.71	26.98	9.00	25.08	8.31	23.97	7.97	23.02	7.64	21.11	6.98
	-13.7	-15	28.89	9.53	26.98	8.84	25.08	8.17	23.97	7.83	23.02	7.51	21.11	6.86
	-11.8	-13	28.89	9.35	26.98	8.68	25.08	8.03	23.97	7.69	23.02	7.37	21.11	6.75
	-9.8	-11	28.89	9.19	26.98	8.54	25.08	7.89	23.97	7.57	23.02	7.25	21.11	6.63
	-9.5	-10	28.89	9.11	26.98	8.45	25.08	7.82	23.97	7.50	23.02	7.20	21.11	6.58
	-8.5	-9.1	28.89	9.04	26.98	8.40	25.08	7.76	23.97	7.44	23.02	7.14	21.11	6.54
	-7	-7.6	28.89	8.93	26.98	8.29	25.08	7.66	23.97	7.36	23.02	7.05	21.11	6.45
	-5	-5.6	28.89	8.72	26.98	8.10	25.08	7.50	23.97	7.21	23.02	6.91	21.11	6.35
	-3	-3.7	28.89	9.04	26.98	8.40	25.08	7.78	23.97	7.48	23.02	7.18	21.11	6.58
	0	-0.7	28.89	9.51	26.98	8.84	25.08	8.20	23.97	7.89	23.02	7.57	21.11	6.95
	3	2.2	28.89	8.36	26.98	7.80	25.08	7.23	23.97	6.97	23.02	6.68	21.11	6.15
	5	4.1	28.89	7.90	26.98	7.39	25.08	6.91	23.97	6.67	23.02	6.42	21.11	5.94
	7	6	28.89	7.18	26.98	6.77	25.08	6.35	23.97	6.15	23.02	5.94	21.11	5.53
	9	7.9	28.89	7.05	26.98	6.68	25.08	6.31	23.97	6.14	23.02	5.94	21.11	5.59
11	9.8	28.89	6.95	26.98	6.61	25.08	6.28	23.97	6.12	23.02	5.96	21.11	5.62	
13	11.8	28.89	6.86	26.98	6.56	25.08	6.28	23.97	6.12	23.02	5.96	21.11	5.69	
15	13.7	28.89	6.84	26.98	6.56	25.08	6.29	23.97	6.17	23.02	6.05	21.11	5.78	

Обозначения:

ТС: Полная производительность (кВт);
 PI: Потребляемая мощность (компрессор + двигатель вентилятора наружного блока) (кВт)

Примечание: 1. В серых ячейках указаны расчётные значения.

Таблица 2-8.10: Таблица теплопроизводительности для блоков производительностью 20 л.с.

CR	Температура наружного воздуха(°C DB)		Температура в помещении °C DB											
			16.0		18.0		20.0		21.0		22.0		24.0	
			ТС	PI	ТС	PI	ТС	PI	ТС	PI	ТС	PI	ТС	PI
°C DB	°C WB	кВт	кВт	кВт	кВт	кВт	кВт	кВт	кВт	кВт	кВт	кВт	кВт	
130%	-25	-25.4	45.14	15.07	44.96	15.22	44.78	15.38	44.64	15.47	44.61	15.57	44.36	15.77
	-19.8	-20	45.92	15.10	45.74	15.25	45.56	15.41	45.39	15.50	45.39	15.60	45.21	15.81
	-18.8	-19	46.27	15.12	46.09	15.25	45.92	15.43	45.92	15.52	45.74	15.62	45.56	15.81
	-16.7	-17	46.98	15.14	46.80	15.29	46.63	15.45	46.63	15.54	46.45	15.64	46.27	15.85
	-13.7	-15	47.69	15.16	47.51	15.31	47.34	15.48	47.34	15.58	47.16	15.68	46.98	15.87
	-11.8	-13	48.40	15.20	48.22	15.35	48.04	15.50	48.04	15.60	47.87	15.69	47.87	15.90
	-9.8	-11	49.11	15.22	48.93	15.37	48.75	15.54	48.75	15.62	48.75	15.71	48.58	15.92
	-9.5	-10	49.46	15.23	49.29	15.37	49.29	15.54	49.11	15.64	49.11	15.73	48.93	15.94
	-8.5	-9.1	49.82	15.23	49.64	15.39	49.46	15.56	49.46	15.66	49.46	15.75	49.29	15.96
	-7	-7.6	50.35	15.25	50.17	15.41	50.17	15.58	50.00	15.68	50.00	15.77	49.82	15.98
	-5	-5.6	54.25	16.36	54.07	16.54	53.90	16.71	53.90	16.82	53.72	16.92	53.54	17.13
	-3	-3.7	54.96	17.23	54.78	17.42	54.60	17.61	54.60	17.70	54.43	17.82	54.25	18.05
	0	-0.7	56.02	18.60	55.85	18.81	55.67	19.02	55.67	19.12	55.49	19.23	55.49	19.48
	3	2.2	61.16	18.26	61.16	18.45	60.99	18.66	60.81	18.76	60.81	18.87	60.63	18.66
	5	4.1	76.94	22.58	76.77	22.45	72.69	20.54	69.85	19.60	67.01	18.68	61.52	16.88
	7	6	83.86	20.63	78.18	19.06	72.69	17.53	69.85	16.79	67.01	16.04	61.52	14.60
9	7.9	83.86	18.83	78.18	17.49	72.69	16.17	69.85	15.54	67.01	14.91	61.52	13.65	
11	9.8	83.86	17.26	78.18	16.10	72.69	14.99	69.85	14.45	67.01	13.90	61.52	12.80	
13	11.8	83.86	15.90	78.18	14.91	72.69	13.95	69.85	13.47	67.01	13.00	61.52	12.06	
15	13.7	83.86	14.87	78.18	14.01	72.69	13.17	69.85	12.75	67.01	12.33	61.52	11.50	
120%	-25	-25.4	45.27	15.75	45.10	15.90	44.43	16.08	44.92	16.17	44.73	16.28	44.60	16.49
	-19.8	-20	45.87	15.77	45.69	15.93	45.51	16.10	45.51	16.20	45.33	16.30	45.16	16.52
	-18.8	-19	46.22	15.79	46.04	15.94	45.87	16.12	45.87	16.20	45.69	16.32	45.51	16.52
	-16.7	-17	46.93	15.81	46.76	15.96	46.58	16.14	46.58	16.24	46.40	16.34	46.40	16.56
	-13.7	-15	47.64	15.83	47.47	16.00	47.29	16.18	47.29	16.26	47.29	16.38	47.11	16.58
	-11.8	-13	48.36	15.87	48.18	16.02	49.42	16.20	48.00	16.30	48.00	16.40	47.82	16.62
	-9.8	-11	49.07	15.89	48.89	16.04	48.89	16.22	48.71	16.32	48.71	16.42	48.53	16.64
	-9.5	-10	49.42	15.91	49.24	16.06	49.24	16.24	49.07	16.34	49.07	16.44	48.89	16.66
	-8.5	-9.1	49.78	15.91	49.60	16.08	49.60	16.26	49.42	16.36	49.42	16.46	49.24	16.66
	-7	-7.6	50.31	15.93	50.13	16.10	50.13	16.28	49.96	16.38	49.96	16.48	49.78	16.68
	-5	-5.6	54.22	17.09	54.04	17.27	53.87	17.47	53.87	17.57	53.87	17.66	53.69	17.88
	-3	-3.7	54.93	18.00	54.76	18.20	54.58	18.40	54.58	18.49	54.40	18.61	54.40	18.83
	0	-0.7	56.00	19.44	55.82	19.64	55.64	19.86	55.64	19.98	55.64	20.09	55.47	20.21
	3	2.2	61.16	19.09	61.16	19.26	60.98	19.48	60.80	19.58	60.80	19.44	56.89	17.51
	5	4.1	76.98	22.88	72.36	21.04	67.20	19.28	64.53	18.41	62.04	17.57	56.89	15.91
	7	6	77.51	19.44	72.36	17.98	67.20	16.56	64.53	15.87	62.04	15.19	56.89	13.85
9	7.9	77.51	17.84	72.36	16.60	67.20	15.39	64.53	14.78	62.04	14.19	56.89	13.02	
11	9.8	77.51	16.46	72.36	15.39	67.20	14.34	64.53	13.83	62.04	13.32	56.89	12.29	
13	11.8	77.51	15.23	72.36	14.32	67.20	13.42	64.53	12.96	62.04	12.53	56.89	11.64	
15	13.7	77.51	14.32	72.36	13.53	67.20	12.72	64.53	12.33	62.04	11.95	56.89	11.18	
110%	-25	-25.4	45.03	16.16	44.83	16.33	44.61	16.51	44.67	16.60	44.51	16.71	44.50	16.92
	-19.8	-20	45.69	16.18	45.51	16.36	45.33	16.54	45.33	16.62	45.16	16.74	45.16	16.94
	-18.8	-19	46.04	16.20	45.87	16.36	45.69	16.54	45.69	16.64	45.51	16.74	45.51	16.96
	-16.7	-17	46.76	16.22	46.58	16.40	46.40	16.58	46.40	16.68	46.40	16.78	46.22	16.98
	-13.7	-15	47.47	16.26	47.29	16.42	47.11	16.60	47.11	16.70	47.11	16.80	46.93	17.02
	-11.8	-13	48.18	16.28	48.00	16.46	48.00	16.64	47.82	16.74	47.82	16.84	47.64	17.04
	-9.8	-11	48.89	16.32	48.71	16.48	48.71	16.66	48.53	16.76	48.53	16.86	48.36	17.08
	-9.5	-10	49.24	16.32	49.24	16.50	49.07	16.68	48.89	16.78	48.89	16.88	48.71	17.08
	-8.5	-9.1	49.60	16.34	49.42	16.50	49.42	16.70	49.24	16.78	49.24	16.88	49.07	17.10
	-7	-7.6	50.13	16.36	49.96	16.52	49.96	16.72	49.78	16.80	49.78	16.90	49.60	17.12
	-5	-5.6	54.04	17.57	53.87	17.75	53.69	17.93	53.69	18.03	53.69	18.13	52.09	16.98
	-3	-3.7	54.76	18.49	54.58	18.69	54.40	18.89	54.40	18.99	54.40	19.09	52.09	17.57
	0	-0.7	55.82	19.97	55.64	20.17	55.64	20.39	55.47	20.51	55.47	20.49	52.09	18.45
	3	2.2	60.98	19.59	60.98	19.79	60.80	19.53	59.20	18.63	56.89	17.75	52.09	16.00
	5	4.1	71.11	20.89	66.31	19.25	61.69	17.67	59.20	18.89	56.89	16.12	52.09	14.64
	7	6	71.11	17.87	66.31	16.56	61.69	15.28	59.20	14.66	56.89	14.04	52.09	12.84
9	7.9	71.11	16.52	66.31	15.38	61.69	14.28	59.20	13.74	56.89	13.20	52.09	12.16	
11	9.8	71.11	15.34	66.31	14.36	61.69	13.40	59.20	12.94	56.89	12.46	52.09	11.54	
13	11.8	71.11	14.28	66.31	13.44	61.69	12.62	59.20	12.22	56.89	11.80	52.09	11.00	
15	13.7	71.11	13.52	66.31	12.78	61.69	12.04	59.20	11.68	56.89	11.34	52.09	10.62	

Обозначения:

- CR: Индекс установленной мощности;
- ТС: Полная производительность (кВт);
- PI: Потребляемая мощность (компрессор + двигатель вентилятора наружного блока) (кВт)

Примечание: 1. В серых ячейках указаны расчётные значения.

Продолжение таблицы на следующей странице...

MVS FDC II-S

Таблица 2-8.10: Таблица теплопроизводительности для блоков производительностью 20 л.с. (продолжение)

CR	Температура наружного воздуха (°C DB)		Температура в помещении °C DB											
			16.0		18.0		20.0		21.0		22.0		24.0	
			ТС	PI	ТС	PI	ТС	PI	ТС	PI	ТС	PI	ТС	PI
°C DB	°C WB	кВт	кВт	кВт	кВт	кВт	кВт	кВт	кВт	кВт	кВт	кВт	кВт	
100%	-25	-25.4	45.51	16.42	45.33	16.58	45.16	16.76	45.16	16.86	45.16	16.96	44.98	17.18
	-19.8	-20	45.87	16.42	45.69	16.60	45.51	16.78	45.51	16.88	45.51	16.98	45.33	17.18
	-18.8	-19	46.58	16.46	46.40	16.64	46.22	16.82	46.22	16.90	46.22	17.00	46.04	17.20
	-16.7	-17	47.29	16.48	47.11	16.66	47.11	16.84	46.93	16.94	46.93	17.04	46.76	16.84
	-13.7	-15	48.00	16.52	47.82	16.68	47.82	16.88	47.64	16.96	47.64	17.06	47.47	16.50
	-11.8	-13	48.71	16.54	48.53	16.72	48.53	16.90	48.36	17.00	48.36	17.08	47.47	16.18
	-9.8	-11	49.07	16.56	49.07	16.74	48.89	16.92	48.89	17.00	48.71	17.10	47.47	16.02
	-9.5	-10	49.42	16.58	49.24	16.74	49.24	16.92	49.07	17.02	49.07	17.12	47.47	15.88
	-8.5	-9.1	49.96	16.60	49.96	16.76	49.78	16.94	49.60	17.04	49.60	17.14	47.47	15.66
	-7	-7.6	53.87	16.62	53.69	16.77	53.69	16.95	53.51	17.67	51.73	16.80	47.47	15.16
	-5	-5.6	54.58	16.64	54.40	16.78	54.40	16.96	53.87	18.27	51.73	17.39	47.47	15.68
	-3	-3.7	55.64	16.66	55.47	16.79	55.47	16.40	53.87	17.18	51.73	18.27	47.47	16.48
	0	-0.7	57.07	16.68	60.27	16.80	56.00	15.95	53.87	18.07	51.73	17.22	47.47	15.48
	3	2.2	60.80	17.73	60.27	16.38	56.00	15.49	53.87	16.62	51.73	15.86	47.47	14.34
	5	4.1	64.53	16.81	60.27	15.58	56.00	14.76	53.87	15.18	51.73	14.50	47.47	13.20
	7	6	64.53	15.89	60.27	14.78	56.00	13.82	53.87	13.28	51.73	12.72	47.47	11.66
	9	7.9	64.53	14.98	60.27	14.00	56.00	13.02	53.87	12.54	51.73	12.06	47.47	11.12
11	9.8	64.53	14.02	60.27	13.14	56.00	12.30	53.87	11.88	51.73	11.46	47.47	10.64	
13	11.8	64.53	13.14	60.27	12.40	56.00	11.66	53.87	11.30	51.73	10.94	47.47	10.21	
15	13.7	64.53	12.50	60.27	11.86	56.00	11.20	53.87	10.88	51.73	10.56	47.47	9.91	
90%	-25	-25.4	44.50	16.65	44.27	16.81	44.12	17.00	44.09	17.34	44.79	17.65	42.67	15.96
	-19.8	-20	45.33	16.68	45.16	16.84	44.98	17.02	44.98	17.12	44.98	17.22	42.67	15.62
	-18.8	-19	45.69	16.70	45.51	16.86	45.33	17.04	45.33	17.14	45.33	17.16	42.67	15.46
	-16.7	-17	46.40	16.72	46.22	16.88	46.22	17.06	46.04	17.16	46.04	16.82	42.67	15.14
	-13.7	-15	47.11	16.74	46.93	16.92	46.93	17.10	46.76	17.18	46.58	16.48	42.67	14.84
	-11.8	-13	47.82	16.78	47.64	16.94	47.64	17.12	47.47	16.96	46.58	16.14	42.67	14.56
	-9.8	-11	48.53	16.80	48.53	16.98	48.36	17.14	48.36	16.62	46.58	15.84	42.67	14.28
	-9.5	-10	48.89	16.82	48.89	16.98	48.71	17.16	48.53	16.46	46.58	15.68	42.67	14.14
	-8.5	-9.1	49.24	16.84	49.07	17.00	49.07	17.12	48.53	16.32	46.58	15.54	42.67	14.02
	-7	-7.6	49.78	16.86	49.78	17.02	49.60	16.88	48.53	16.10	46.58	15.32	42.67	13.82
	-5	-5.6	53.69	16.89	53.51	17.04	50.49	16.30	48.53	15.56	46.58	14.84	42.67	13.42
	-3	-3.7	54.40	16.92	54.22	17.06	50.49	16.86	48.53	16.10	46.58	15.36	42.67	13.88
	0	-0.7	55.47	16.94	54.22	17.08	50.49	17.73	48.53	16.92	46.58	16.14	42.67	14.60
	3	2.2	58.13	16.96	54.22	16.78	50.49	15.40	48.53	14.72	46.58	14.04	42.67	12.74
	5	4.1	58.13	16.54	54.22	15.32	50.49	14.12	48.53	13.52	46.58	12.94	42.67	11.82
	7	6	58.13	14.38	54.22	13.38	50.49	12.40	48.53	11.92	46.58	11.46	42.67	10.52
	9	7.9	58.13	13.50	54.22	12.64	50.49	11.78	48.53	11.36	46.58	10.94	42.67	10.11
11	9.8	58.13	12.72	54.22	11.96	50.49	11.22	48.53	10.84	46.58	10.48	42.67	9.75	
13	11.8	58.13	12.02	54.22	11.36	50.49	10.72	48.53	10.40	46.58	10.07	42.67	9.43	
15	13.7	58.13	11.52	54.22	10.94	50.49	10.35	48.53	10.07	46.58	9.79	42.67	9.21	
80%	-25	-25.4	44.33	16.72	44.15	17.18	44.80	16.72	43.02	15.94	41.42	15.19	37.87	13.70
	-19.8	-20	45.16	16.75	44.98	16.93	44.80	16.36	43.02	15.60	41.42	14.87	37.87	13.43
	-18.8	-19	45.51	16.77	45.33	16.93	44.80	16.20	43.02	15.45	41.42	14.71	37.87	13.29
	-16.7	-17	46.22	16.79	46.04	16.97	44.80	15.86	43.02	15.13	41.42	14.42	37.87	13.01
	-13.7	-15	46.93	16.83	46.76	16.99	44.80	15.55	43.02	14.83	41.42	14.14	37.87	12.78
	-11.8	-13	47.64	16.85	47.47	16.67	44.80	15.23	43.02	14.54	41.42	13.86	37.87	12.54
	-9.8	-11	48.36	16.87	48.18	16.34	44.80	14.95	43.02	14.26	41.42	13.61	37.87	12.30
	-9.5	-10	48.71	16.89	48.18	16.18	44.80	14.79	43.02	14.12	41.42	13.47	37.87	12.18
	-8.5	-9.1	49.07	16.91	48.18	16.04	44.80	14.68	43.02	14.00	41.42	13.35	37.87	12.08
	-7	-7.6	49.60	16.93	48.18	15.80	44.80	14.48	43.02	13.82	41.42	13.17	37.87	11.93
	-5	-5.6	51.73	16.59	48.18	15.29	44.80	14.02	43.02	13.39	41.42	12.80	37.87	11.59
	-3	-3.7	51.73	17.17	48.18	15.82	44.80	14.52	43.02	13.86	41.42	13.23	37.87	12.01
	0	-0.7	51.73	18.04	48.18	16.63	44.80	15.25	43.02	14.58	41.42	13.92	37.87	12.64
	3	2.2	51.73	15.66	48.18	14.46	44.80	13.29	43.02	12.72	41.42	12.16	37.87	11.06
	5	4.1	51.73	14.32	48.18	13.29	44.80	12.28	43.02	11.79	41.42	11.29	37.87	10.34
	7	6	51.73	12.56	48.18	11.73	44.80	10.90	43.02	10.48	41.42	10.09	37.87	9.30
	9	7.9	51.73	11.91	48.18	11.17	44.80	10.44	43.02	10.09	41.42	9.71	37.87	9.02
11	9.8	51.73	11.31	48.18	10.66	44.80	10.03	43.02	9.71	41.42	9.39	37.87	8.78	
13	11.8	51.73	10.80	48.18	10.23	44.80	9.67	43.02	9.39	41.42	9.12	37.87	8.56	
15	13.7	51.73	10.42	48.18	9.91	44.80	9.41	43.02	9.18	41.42	8.92	37.87	8.43	

Обозначения:

CR: Индекс установленной мощности;
 ТС: Полная производительность (кВт);
 PI: Потребляемая мощность (компрессор + двигатель вентилятора наружного блока) (кВт)

Примечание: 1. В серых ячейках указаны расчётные значения.

Продолжение таблицы на следующей странице...

Таблица 2-8.11: Таблица теплопроизводительности для блоков производительностью 20 л.с. (продолжение)

CR	Температура наружного воздуха (°C DB)		Температура в помещении °C DB											
			16.0		18.0		20.0		21.0		22.0		24.0	
			ТС	PI	ТС	PI	ТС	PI	ТС	PI	ТС	PI	ТС	PI
°C DB	°C WB	кВт	кВт	кВт	кВт	кВт	кВт	кВт	кВт	кВт	кВт	кВт	кВт	
70%	-25	-25.4	44.87	17.12	42.13	15.74	39.29	14.42	37.69	13.77	36.27	13.14	33.24	11.89
	-19.8	-20	44.80	16.76	42.13	15.42	39.29	14.14	37.69	13.50	36.27	12.88	33.24	11.66
	-18.8	-19	45.16	16.58	42.13	15.26	39.29	13.98	37.69	13.36	36.27	12.76	33.24	11.56
	-16.7	-17	45.16	16.24	42.13	14.96	39.29	13.72	37.69	13.10	36.27	12.50	33.24	11.34
	-13.7	-15	45.16	15.92	42.13	14.66	39.29	13.44	37.69	12.86	36.27	12.26	33.24	11.12
	-11.8	-13	45.16	15.60	42.13	14.38	39.29	13.20	37.69	12.60	36.27	12.04	33.24	10.92
	-9.8	-11	45.16	15.30	42.13	14.10	39.29	12.94	37.69	12.38	36.27	11.82	33.24	10.72
	-9.5	-10	45.16	15.16	42.13	13.98	39.29	12.82	37.69	12.26	36.27	11.70	33.24	10.64
	-8.5	-9.1	45.16	15.02	42.13	13.86	39.29	12.72	37.69	12.16	36.27	11.62	33.24	10.54
	-7	-7.6	45.16	14.82	42.13	13.66	39.29	12.54	37.69	12.00	36.27	11.46	33.24	10.40
	-5	-5.6	45.16	14.36	42.13	13.26	39.29	12.20	37.69	11.68	36.27	11.16	33.24	10.15
	-3	-3.7	45.16	14.86	42.13	13.72	39.29	12.62	37.69	12.08	36.27	11.56	33.24	10.52
	0	-0.7	45.16	15.62	42.13	14.44	39.29	13.28	37.69	12.72	36.27	12.16	33.24	11.08
	3	2.2	45.16	13.60	42.13	12.60	39.29	11.62	37.69	11.14	36.27	10.66	33.24	9.73
	5	4.1	45.16	12.56	42.13	11.70	39.29	10.84	37.69	10.42	36.27	9.99	33.24	9.17
	7	6	45.16	11.14	42.13	10.42	39.29	9.71	37.69	9.35	36.27	9.01	33.24	8.33
9	7.9	45.16	10.66	42.13	10.01	39.29	9.39	37.69	11.10	36.27	8.77	33.24	8.17	
11	9.8	45.16	10.23	42.13	9.67	39.29	9.11	37.69	8.85	36.27	8.57	33.24	8.03	
13	11.8	45.16	9.85	42.13	9.37	39.29	8.87	37.69	8.63	36.27	8.39	33.24	7.91	
15	13.7	45.16	9.59	42.13	9.15	39.29	8.73	37.69	8.51	36.27	8.29	33.24	7.87	
60%	-25	-25.4	38.76	14.26	36.27	13.15	33.60	12.07	32.36	11.55	30.93	11.03	28.44	10.03
	-19.8	-20	38.76	13.96	36.27	12.88	33.60	11.84	32.36	11.32	30.93	10.82	28.44	9.83
	-18.8	-19	38.76	13.82	36.27	12.76	33.60	11.72	32.36	11.22	30.93	10.72	28.44	9.75
	-16.7	-17	38.76	13.54	36.27	12.50	33.60	11.50	32.36	11.00	30.93	10.52	28.44	9.57
	-13.7	-15	38.76	13.28	36.27	12.26	33.60	11.28	32.36	10.80	30.93	10.33	28.44	9.39
	-11.8	-13	38.76	13.02	36.27	12.04	33.60	11.08	32.36	10.60	30.93	10.13	28.44	9.23
	-9.8	-11	38.76	12.78	36.27	11.82	33.60	10.88	32.36	10.42	30.93	9.95	28.44	9.07
	-9.5	-10	38.76	12.66	36.27	11.70	33.60	10.78	32.36	10.31	30.93	9.87	28.44	8.99
	-8.5	-9.1	38.76	12.57	36.27	11.62	33.60	10.70	32.36	10.23	30.93	9.79	28.44	8.93
	-7	-7.6	38.76	12.38	36.27	11.46	33.60	10.56	32.36	10.11	30.93	9.67	28.44	8.81
	-5	-5.6	38.76	12.04	36.27	11.16	33.60	10.29	32.36	9.87	30.93	9.45	28.44	8.63
	-3	-3.7	38.76	12.48	36.27	11.56	33.60	10.66	32.36	10.23	30.93	9.79	28.44	8.95
	0	-0.7	38.76	13.12	36.27	12.16	33.60	11.24	32.36	10.78	30.93	10.31	28.44	9.43
	3	2.2	38.76	11.48	36.27	10.66	33.60	9.85	32.36	9.47	30.93	9.07	28.44	8.31
	5	4.1	38.76	10.72	36.27	9.99	33.60	9.29	32.36	8.95	30.93	8.61	28.44	7.93
	7	6	38.76	9.61	36.27	9.01	33.60	8.43	32.36	8.13	30.93	7.85	28.44	7.29
9	7.9	38.76	9.31	36.27	8.77	33.60	8.25	32.36	7.99	30.93	7.75	28.44	7.23	
11	9.8	38.76	9.03	36.27	8.57	33.60	8.11	32.36	7.87	30.93	7.65	28.44	7.19	
13	11.8	38.76	8.81	36.27	8.39	33.60	7.99	32.36	7.77	30.93	7.57	28.44	7.17	
15	13.7	38.76	8.67	36.27	8.29	33.60	7.93	32.36	7.75	30.93	7.57	28.44	7.19	
50%	-25	-25.4	32.36	11.52	30.22	10.68	28.09	9.85	26.84	10.31	25.78	9.04	23.64	8.27
	-19.8	-20	32.36	11.32	30.22	10.50	28.09	9.67	26.84	9.29	25.78	8.89	23.64	8.13
	-18.8	-19	32.36	11.22	30.22	10.40	28.09	9.59	26.84	11.20	25.78	8.81	23.64	8.05
	-16.7	-17	32.36	11.00	30.22	10.19	28.09	9.41	26.84	9.03	25.78	8.65	23.64	7.91
	-13.7	-15	32.36	10.80	30.22	10.01	28.09	9.25	26.84	8.87	25.78	8.51	23.64	7.77
	-11.8	-13	32.36	10.60	30.22	9.83	28.09	9.09	26.84	8.71	25.78	8.35	23.64	7.65
	-9.8	-11	32.36	10.42	30.22	9.67	28.09	8.93	26.84	8.57	25.78	8.21	23.64	7.51
	-9.5	-10	32.36	10.31	30.22	9.57	28.09	8.85	26.84	8.49	25.78	8.15	23.64	7.45
	-8.5	-9.1	32.36	10.23	30.22	9.51	28.09	8.79	26.84	8.43	25.78	8.09	23.64	7.41
	-7	-7.6	32.36	10.11	30.22	9.39	28.09	8.67	26.84	8.33	25.78	7.99	23.64	7.31
	-5	-5.6	32.36	9.87	30.22	9.17	28.09	8.49	26.84	8.17	25.78	7.83	23.64	7.19
	-3	-3.7	32.36	10.23	30.22	9.51	28.09	8.81	26.84	8.47	25.78	8.13	23.64	7.45
	0	-0.7	32.36	10.78	30.22	10.01	28.09	9.29	26.84	8.93	25.78	8.57	23.64	7.87
	3	2.2	32.36	9.47	30.22	8.83	28.09	8.19	26.84	7.89	25.78	7.57	23.64	6.97
	5	4.1	32.36	8.95	30.22	8.37	28.09	7.83	26.84	7.55	25.78	7.27	23.64	6.73
	7	6	32.36	8.13	30.22	7.67	28.09	7.19	26.84	6.97	25.78	6.73	23.64	6.27
9	7.9	32.36	7.99	30.22	7.57	28.09	7.15	26.84	6.95	25.78	6.73	23.64	6.33	
11	9.8	32.36	7.87	30.22	7.49	28.09	7.11	26.84	6.93	25.78	6.75	23.64	6.37	
13	11.8	32.36	7.77	30.22	7.43	28.09	7.11	26.84	6.93	25.78	6.75	23.64	6.45	
15	13.7	32.36	7.75	30.22	7.43	28.09	7.13	26.84	6.99	25.78	6.85	23.64	6.55	

Обозначения:

- CR: Индекс установленной мощности;
- ТС: Полная производительность (кВт);
- PI: Потребляемая мощность (компрессор + двигатель вентилятора наружного блока) (кВт)

Примечание: 1. В серых ячейках указаны расчётные значения.

MVS FDC II-S

Таблица 2-8.12: Таблица теплопроизводительности для блоков производительностью 22 л.с.

CR	Температура наружного воздуха (°C DB)		Температура в помещении °C DB											
			16.0		18.0		20.0		21.0		22.0		24.0	
			ТС	PI	ТС	PI	ТС	PI	ТС	PI	ТС	PI	ТС	PI
°C DB	°C WB	кВт	кВт	кВт	кВт	кВт	кВт	кВт	кВт	кВт	кВт	кВт	кВт	
130%	-25	-25.4	49.57	19.16	49.38	19.35	49.18	19.55	49.03	19.67	48.99	19.79	48.71	20.05
	-19.8	-20	50.43	19.20	50.23	19.39	50.04	19.59	49.84	19.71	49.84	19.83	49.65	20.10
	-18.8	-19	50.82	19.22	50.62	19.39	50.43	19.61	50.43	19.73	50.23	19.86	50.04	20.10
	-16.7	-17	51.60	19.25	51.40	19.44	51.21	19.64	51.21	19.76	51.01	19.88	50.82	20.15
	-13.7	-15	52.37	19.27	52.18	19.47	51.98	19.69	51.98	19.81	51.79	19.93	51.60	20.17
	-11.8	-13	53.15	19.32	52.96	19.51	52.76	19.71	52.76	19.83	52.57	19.95	52.57	20.22
	-9.8	-11	53.93	19.34	53.74	19.54	53.54	19.76	53.54	19.86	53.54	19.98	53.35	20.24
	-9.5	-10	54.32	19.37	54.13	19.54	54.13	19.76	53.93	19.88	53.93	20.00	53.74	20.27
	-8.5	-9.1	54.71	19.37	54.52	19.56	54.32	19.78	54.32	19.90	54.32	20.03	54.13	20.29
	-7	-7.6	55.29	19.39	55.10	19.59	55.10	19.81	54.91	19.93	54.91	20.05	54.71	20.32
	-5	-5.6	59.58	20.80	59.38	21.02	59.19	21.24	59.19	21.39	58.99	21.51	58.80	21.78
	-3	-3.7	60.36	21.90	60.16	22.14	59.97	22.39	59.97	22.51	59.77	22.65	59.58	22.95
	0	-0.7	61.53	23.65	61.33	23.92	61.14	24.19	61.14	24.31	60.94	24.45	60.94	24.77
	3	2.2	67.17	23.21	67.17	23.46	66.98	23.72	66.78	23.85	66.78	23.99	66.59	23.72
	5	4.1	84.50	28.71	84.31	28.54	79.83	26.11	76.71	24.92	73.60	23.75	67.56	21.46
7	6	92.09	26.23	85.86	24.24	79.83	22.29	76.71	21.34	73.60	20.39	67.56	18.57	
9	7.9	92.09	23.94	85.86	22.24	79.83	20.56	76.71	19.76	73.60	18.96	67.56	17.35	
11	9.8	92.09	21.95	85.86	20.46	79.83	19.05	76.71	18.37	73.60	17.67	67.56	16.28	
13	11.8	92.09	20.22	85.86	18.96	79.83	17.74	76.71	17.13	73.60	16.52	67.56	15.33	
15	13.7	92.09	18.91	85.86	17.81	79.83	16.74	76.71	16.21	73.60	15.67	67.56	14.62	
120%	-25	-25.4	49.72	20.02	49.53	20.22	103.70	20.45	49.33	20.56	49.12	20.70	48.98	20.97
	-19.8	-20	50.37	20.05	50.18	20.25	49.98	20.47	49.98	20.60	49.79	20.72	49.59	21.00
	-18.8	-19	50.76	20.07	50.57	20.27	50.37	20.50	50.37	20.60	50.18	20.75	49.98	21.00
	-16.7	-17	51.54	20.10	51.35	20.30	51.15	20.52	51.15	20.65	50.96	20.77	50.96	21.05
	-13.7	-15	52.32	20.12	52.13	20.35	51.93	20.57	51.93	20.67	51.93	20.82	51.74	21.08
	-11.8	-13	53.10	20.17	52.91	20.37	54.28	20.60	52.71	20.72	52.71	20.85	52.52	21.13
	-9.8	-11	53.89	20.20	53.69	20.40	53.69	20.62	53.50	20.75	53.50	20.87	53.30	21.15
	-9.5	-10	54.28	20.22	54.08	20.42	54.08	20.65	53.89	20.77	53.89	20.90	53.69	21.18
	-8.5	-9.1	54.67	20.22	54.47	20.45	54.47	20.67	54.28	20.80	54.28	20.92	54.08	21.18
	-7	-7.6	55.25	20.25	55.06	20.47	55.06	20.70	54.86	20.82	54.86	20.95	54.67	21.20
	-5	-5.6	59.55	21.73	59.35	21.95	59.16	22.21	59.16	22.33	59.16	22.46	58.96	22.73
	-3	-3.7	60.33	22.88	60.13	23.14	59.94	23.39	59.94	23.51	59.74	23.66	59.74	23.94
	0	-0.7	61.50	24.72	61.30	24.97	61.11	25.25	61.11	25.40	61.11	25.55	60.91	25.70
	3	2.2	67.16	24.27	67.16	24.49	66.97	24.77	66.77	24.89	66.77	24.72	62.48	22.26
	5	4.1	84.54	29.09	79.46	26.75	73.80	24.52	70.87	23.41	68.14	22.33	62.48	20.22
7	6	85.12	24.72	79.46	22.86	73.80	21.05	70.87	20.17	68.14	19.32	62.48	17.61	
9	7.9	85.12	22.68	79.46	21.10	73.80	19.57	70.87	18.79	68.14	18.04	62.48	16.55	
11	9.8	85.12	20.92	79.46	19.57	73.80	18.24	70.87	17.58	68.14	16.93	62.48	15.62	
13	11.8	85.12	19.37	79.46	18.21	73.80	17.06	70.87	16.48	68.14	15.93	62.48	14.80	
15	13.7	85.12	18.21	79.46	17.21	73.80	16.18	70.87	15.67	68.14	15.20	62.48	14.22	
110%	-25	-25.4	49.45	20.54	49.23	20.77	48.99	20.99	49.06	21.11	48.89	21.25	48.87	21.51
	-19.8	-20	50.18	20.57	49.98	20.80	49.79	21.03	49.79	21.13	49.59	21.29	49.59	21.54
	-18.8	-19	50.57	20.60	50.37	20.80	50.18	21.03	50.18	21.16	49.98	21.29	49.98	21.57
	-16.7	-17	51.35	20.63	51.15	20.85	50.96	21.08	50.96	21.21	50.96	21.34	50.76	21.59
	-13.7	-15	52.13	20.68	51.93	20.88	51.74	21.11	51.74	21.24	51.74	21.36	51.54	21.64
	-11.8	-13	52.91	20.70	52.71	20.93	52.71	21.16	52.52	21.29	52.52	21.42	52.32	21.67
	-9.8	-11	53.69	20.75	53.50	20.96	53.50	21.19	53.30	21.31	53.30	21.44	53.10	21.72
	-9.5	-10	54.08	20.75	54.08	20.98	53.89	21.21	53.69	21.34	53.69	21.47	53.50	21.72
	-8.5	-9.1	54.47	20.78	54.28	20.98	54.28	21.24	54.08	21.34	54.08	21.47	53.89	21.75
	-7	-7.6	55.06	20.80	54.86	21.01	54.86	21.26	54.67	21.36	54.67	21.49	54.47	21.77
	-5	-5.6	59.35	22.33	59.16	22.56	58.96	22.79	58.96	22.92	58.96	23.04	57.20	21.59
	-3	-3.7	60.13	23.50	59.94	23.76	59.74	24.01	59.74	24.14	59.74	24.27	57.20	22.33
	0	-0.7	61.30	25.39	61.11	25.64	61.11	25.92	60.91	26.07	60.91	26.05	57.20	23.45
	3	2.2	66.97	24.90	66.97	25.16	66.77	24.83	65.01	23.68	62.48	22.56	57.20	20.35
	5	4.1	78.10	26.56	72.82	24.47	67.75	22.46	65.01	24.01	62.48	20.50	57.20	18.61
7	6	78.10	22.71	72.82	21.06	67.75	19.43	65.01	18.64	62.48	17.85	57.20	16.32	
9	7.9	78.10	21.01	72.82	19.56	67.75	18.16	65.01	17.47	62.48	16.78	57.20	15.46	
11	9.8	78.10	19.51	72.82	18.26	67.75	17.04	65.01	16.45	62.48	15.84	57.20	14.67	
13	11.8	78.10	18.16	72.82	17.09	67.75	16.04	65.01	15.53	62.48	15.00	57.20	13.98	
15	13.7	78.10	17.19	72.82	16.25	67.75	15.30	65.01	14.85	62.48	14.41	57.20	13.50	

Обозначения:

CR: Индекс установленной мощности;
 ТС: Полная производительность (кВт);
 PI: Потребляемая мощность (компрессор + двигатель вентилятора наружного блока) (кВт)

Примечание: 1. В серых ячейках указаны расчётные значения.

Продолжение таблицы на следующей странице...

Таблица 2-8.12: Таблица теплопроизводительности для блоков производительностью 22 л.с. (продолжение)

CR	Температура наружного воздуха (°C DB)		Температура в помещении °C DB											
			16.0		18.0		20.0		21.0		22.0		24.0	
			ТС	PI	ТС	PI	ТС	PI	ТС	PI	ТС	PI	ТС	PI
100%	-25	-25.4	49.98	20.88	49.79	21.08	49.59	21.31	49.59	21.44	49.59	21.57	49.40	21.85
	-19.8	-20	50.37	20.88	50.18	21.11	49.98	21.34	49.98	21.47	49.98	21.59	49.79	21.85
	-18.8	-19	51.15	20.93	50.96	21.16	50.76	21.39	50.76	21.49	50.76	21.62	50.57	21.87
	-16.7	-17	51.93	20.96	51.74	21.19	51.74	21.42	51.54	21.54	51.54	21.67	51.35	21.42
	-13.7	-15	52.71	21.01	52.52	21.21	52.52	21.47	52.32	21.57	52.32	21.70	52.13	20.98
	-11.8	-13	53.50	21.03	53.30	21.26	53.30	21.49	53.10	21.62	53.10	21.72	52.13	20.57
	-9.8	-11	53.89	21.06	53.89	21.29	53.69	21.52	53.69	21.62	53.50	21.75	52.13	20.37
	-9.5	-10	54.28	21.08	54.08	21.29	54.08	21.52	53.89	21.64	53.89	21.77	52.13	20.19
	-8.5	-9.1	54.86	21.11	54.86	21.31	54.67	21.54	54.47	21.67	54.47	21.80	52.13	19.91
	-7	-7.6	59.16	21.13	58.96	21.32	58.96	21.55	58.77	22.46	56.81	21.36	52.13	19.28
	-5	-5.6	59.94	21.16	59.74	21.33	59.74	21.56	59.16	23.22	56.81	22.10	52.13	19.94
	-3	-3.7	61.11	21.19	60.91	21.35	60.91	20.85	59.16	21.85	56.81	23.22	52.13	20.96
	0	-0.7	62.67	21.21	66.19	21.36	61.50	20.27	59.16	22.97	56.81	21.90	52.13	19.68
	3	2.2	66.77	22.54	66.19	20.83	61.50	19.69	59.16	21.13	56.81	20.17	52.13	18.23
	5	4.1	70.87	21.37	66.19	19.81	61.50	18.76	59.16	19.30	56.81	18.44	52.13	16.78
	7	6	70.87	20.20	66.19	18.79	61.50	17.57	59.16	16.88	56.81	16.17	52.13	14.82
	9	7.9	70.87	19.05	66.19	17.80	61.50	16.55	59.16	15.94	56.81	15.33	52.13	14.13
	11	9.8	70.87	17.82	66.19	16.70	61.50	15.63	59.16	15.10	56.81	14.57	52.13	13.52
13	11.8	70.87	16.70	66.19	15.76	61.50	14.82	59.16	14.36	56.81	13.90	52.13	12.99	
15	13.7	70.87	15.89	66.19	15.07	61.50	14.23	59.16	13.83	56.81	13.42	52.13	12.60	
90%	-25	-25.4	48.87	21.17	48.61	21.37	48.46	21.61	48.42	22.04	49.19	22.43	46.86	20.29
	-19.8	-20	49.79	21.21	49.59	21.42	49.40	21.64	49.40	21.77	49.40	21.90	46.86	19.86
	-18.8	-19	50.18	21.24	49.98	21.44	49.79	21.67	49.79	21.80	49.79	21.82	46.86	19.66
	-16.7	-17	50.96	21.26	50.76	21.47	50.76	21.70	50.57	21.82	50.57	21.39	46.86	19.25
	-13.7	-15	51.74	21.29	51.54	21.52	51.54	21.75	51.35	21.85	51.15	20.96	46.86	18.87
	-11.8	-13	52.52	21.34	52.32	21.54	52.32	21.77	52.13	21.57	51.15	20.52	46.86	18.51
	-9.8	-11	53.30	21.36	53.30	21.59	53.10	21.80	53.10	21.13	51.15	20.14	46.86	18.16
	-9.5	-10	53.69	21.39	53.69	21.59	53.50	21.82	53.30	20.93	51.15	19.94	46.86	17.98
	-8.5	-9.1	54.08	21.42	53.89	21.62	53.89	21.77	53.30	20.75	51.15	19.76	46.86	17.82
	-7	-7.6	54.67	21.44	54.67	21.64	54.47	21.47	53.30	20.47	51.15	19.48	46.86	17.57
	-5	-5.6	58.96	21.48	58.77	21.67	55.45	20.73	53.30	19.79	51.15	18.87	46.86	17.06
	-3	-3.7	59.74	21.51	59.55	21.69	55.45	21.44	53.30	20.47	51.15	19.53	46.86	17.65
	0	-0.7	60.91	21.54	59.55	21.71	55.45	22.54	53.30	21.52	51.15	20.52	46.86	18.56
	3	2.2	63.84	21.57	59.55	21.34	55.45	19.58	53.30	18.72	51.15	17.85	46.86	16.19
	5	4.1	63.84	21.03	59.55	19.48	55.45	17.95	53.30	17.19	51.15	16.45	46.86	15.02
	7	6	63.84	18.28	59.55	17.01	55.45	15.76	53.30	15.15	51.15	14.57	46.86	13.37
	9	7.9	63.84	17.16	59.55	16.07	55.45	14.97	53.30	14.44	51.15	13.90	46.86	12.86
	11	9.8	63.84	16.17	59.55	15.20	55.45	14.26	53.30	13.78	51.15	13.32	46.86	12.40
13	11.8	63.84	15.28	59.55	14.44	55.45	13.62	53.30	13.22	51.15	12.81	46.86	11.99	
15	13.7	63.84	14.64	59.55	13.90	55.45	13.16	53.30	12.81	51.15	12.45	46.86	11.71	
80%	-25	-25.4	48.68	21.26	48.48	21.84	49.20	21.25	47.25	20.27	45.49	19.31	41.59	17.42
	-19.8	-20	49.59	21.30	49.40	21.52	49.20	20.79	47.25	19.84	45.49	18.91	41.59	17.07
	-18.8	-19	49.98	21.32	49.79	21.52	49.20	20.59	47.25	19.64	45.49	18.71	41.59	16.90
	-16.7	-17	50.76	21.35	50.57	21.57	49.20	20.17	47.25	19.24	45.49	18.33	41.59	16.55
	-13.7	-15	51.54	21.40	51.35	21.60	49.20	19.76	47.25	18.86	45.49	17.98	41.59	16.24
	-11.8	-13	52.32	21.42	52.13	21.20	49.20	19.36	47.25	18.48	45.49	17.63	41.59	15.94
	-9.8	-11	53.10	21.45	52.91	20.77	49.20	19.01	47.25	18.13	45.49	17.30	41.59	15.64
	-9.5	-10	53.50	21.47	52.91	20.57	49.20	18.81	47.25	17.95	45.49	17.12	41.59	15.49
	-8.5	-9.1	53.89	21.50	52.91	20.39	49.20	18.66	47.25	17.80	45.49	16.97	41.59	15.36
	-7	-7.6	54.47	21.52	52.91	20.09	49.20	18.41	47.25	17.58	45.49	16.75	41.59	15.16
	-5	-5.6	56.81	21.10	52.91	19.44	49.20	17.83	47.25	17.02	45.49	16.27	41.59	14.73
	-3	-3.7	56.81	21.83	52.91	20.12	49.20	18.46	47.25	17.63	45.49	16.82	41.59	15.26
	0	-0.7	56.81	22.93	52.91	21.15	49.20	19.39	47.25	18.53	45.49	17.70	41.59	16.07
	3	2.2	56.81	19.91	52.91	18.38	49.20	16.90	47.25	16.17	45.49	15.46	41.59	14.06
	5	4.1	56.81	18.20	52.91	16.90	49.20	15.61	47.25	14.99	45.49	14.36	41.59	13.15
	7	6	56.81	15.97	52.91	14.91	49.20	13.85	47.25	13.33	45.49	12.82	41.59	11.82
	9	7.9	56.81	15.14	52.91	14.21	49.20	13.28	47.25	12.82	45.49	12.35	41.59	11.47
	11	9.8	56.81	14.38	52.91	13.55	49.20	12.75	47.25	12.35	45.49	11.94	41.59	11.16
13	11.8	56.81	13.73	52.91	13.00	49.20	12.30	47.25	11.94	45.49	11.59	41.59	10.89	
15	13.7	56.81	13.25	52.91	12.60	49.20	11.97	47.25	11.67	45.49	11.34	41.59	10.71	

Обозначения:

CR: Индекс установленной мощности;

ТС: Полная производительность (кВт);

PI: Потребляемая мощность (компрессор + двигатель вентилятора наружного блока) (кВт)

Примечание: 1. В серых ячейках указаны расчётные значения.

Продолжение таблицы на следующей странице...

MVS FDC II-S

Таблица 2-8.12: Таблица теплопроизводительности для блоков производительностью 22 л.с. (продолжение)

CR	Температура наружного воздуха(°C DB)		Температура в помещении °C DB											
			16.0		18.0		20.0		21.0		22.0		24.0	
			ТС	PI	ТС	PI	ТС	PI	ТС	PI	ТС	PI	ТС	PI
°C DB	°C WB	кВт	кВт	кВт	кВт	кВт	кВт	кВт	кВт	кВт	кВт	кВт	кВт	
70%	-25	-25.4	49.28	21.76	46.27	20.01	43.15	18.34	41.39	17.51	39.83	16.71	36.51	15.12
	-19.8	-20	49.20	21.31	46.27	19.61	43.15	17.98	41.39	17.16	39.83	16.37	36.51	14.82
	-18.8	-19	49.59	21.08	46.27	19.40	43.15	17.77	41.39	16.98	39.83	16.22	36.51	14.69
	-16.7	-17	49.59	20.65	46.27	19.02	43.15	17.44	41.39	16.65	39.83	15.89	36.51	14.41
	-13.7	-15	49.59	20.24	46.27	18.64	43.15	17.09	41.39	16.35	39.83	15.58	36.51	14.13
	-11.8	-13	49.59	19.84	46.27	18.28	43.15	16.78	41.39	16.02	39.83	15.30	36.51	13.88
	-9.8	-11	49.59	19.45	46.27	17.93	43.15	16.45	41.39	15.74	39.83	15.02	36.51	13.62
	-9.5	-10	49.59	19.28	46.27	17.77	43.15	16.30	41.39	15.58	39.83	14.87	36.51	13.52
	-8.5	-9.1	49.59	19.10	46.27	17.62	43.15	16.17	41.39	15.46	39.83	14.77	36.51	13.39
	-7	-7.6	49.59	18.84	46.27	17.37	43.15	15.94	41.39	15.25	39.83	14.57	36.51	13.22
	-5	-5.6	49.59	18.26	46.27	16.86	43.15	15.51	41.39	14.85	39.83	14.18	36.51	12.91
	-3	-3.7	49.59	18.89	46.27	17.44	43.15	16.04	41.39	15.35	39.83	14.69	36.51	13.37
	0	-0.7	49.59	19.86	46.27	18.36	43.15	16.88	41.39	16.17	39.83	15.46	36.51	14.08
	3	2.2	49.59	17.29	46.27	16.02	43.15	14.77	41.39	14.16	39.83	13.55	36.51	12.38
	5	4.1	49.59	15.97	46.27	14.87	43.15	13.78	41.39	13.24	39.83	12.71	36.51	11.66
	7	6	49.59	14.16	46.27	13.24	43.15	12.35	41.39	11.89	39.83	11.46	36.51	10.59
9	7.9	49.59	13.55	46.27	12.73	43.15	11.94	41.39	14.11	39.83	11.15	36.51	10.39	
11	9.8	49.59	13.01	46.27	12.30	43.15	11.59	41.39	11.25	39.83	10.90	36.51	10.21	
13	11.8	49.59	12.53	46.27	11.92	43.15	11.28	41.39	10.97	39.83	10.67	36.51	10.06	
15	13.7	49.59	12.20	46.27	11.64	43.15	11.10	41.39	10.82	39.83	10.54	36.51	10.01	
60%	-25	-25.4	42.56	18.13	39.83	16.71	36.90	15.35	35.53	14.68	33.97	14.03	31.24	12.75
	-19.8	-20	42.56	17.75	39.83	16.37	36.90	15.05	35.53	14.39	33.97	13.75	31.24	12.50
	-18.8	-19	42.56	17.57	39.83	16.22	36.90	14.90	35.53	14.26	33.97	13.62	31.24	12.40
	-16.7	-17	42.56	17.21	39.83	15.89	36.90	14.62	35.53	13.98	33.97	13.37	31.24	12.17
	-13.7	-15	42.56	16.88	39.83	15.58	36.90	14.34	35.53	13.72	33.97	13.14	31.24	11.94
	-11.8	-13	42.56	16.55	39.83	15.30	36.90	14.08	35.53	13.47	33.97	12.88	31.24	11.74
	-9.8	-11	42.56	16.25	39.83	15.02	36.90	13.83	35.53	13.24	33.97	12.66	31.24	11.54
	-9.5	-10	42.56	16.09	39.83	14.87	36.90	13.70	35.53	13.11	33.97	12.55	31.24	11.43
	-8.5	-9.1	42.56	15.99	39.83	14.77	36.90	13.60	35.53	13.01	33.97	12.45	31.24	11.36
	-7	-7.6	42.56	15.74	39.83	14.57	36.90	13.42	35.53	12.86	33.97	12.30	31.24	11.20
	-5	-5.6	42.56	15.30	39.83	14.18	36.90	13.09	35.53	12.55	33.97	12.02	31.24	10.97
	-3	-3.7	42.56	15.86	39.83	14.69	36.90	13.55	35.53	13.01	33.97	12.45	31.24	11.38
	0	-0.7	42.56	16.68	39.83	15.46	36.90	14.29	35.53	13.70	33.97	13.11	31.24	11.99
	3	2.2	42.56	14.59	39.83	13.55	36.90	12.53	35.53	12.04	33.97	11.54	31.24	10.57
	5	4.1	42.56	13.62	39.83	12.71	36.90	11.82	35.53	11.38	33.97	10.95	31.24	10.08
	7	6	42.56	12.22	39.83	11.46	36.90	10.72	35.53	10.34	33.97	9.98	31.24	9.27
9	7.9	42.56	11.84	39.83	11.15	36.90	10.49	35.53	10.16	33.97	9.85	31.24	9.19	
11	9.8	42.56	11.48	39.83	10.90	36.90	10.31	35.53	10.01	33.97	9.73	31.24	9.14	
13	11.8	42.56	11.20	39.83	10.67	36.90	10.16	35.53	9.88	33.97	9.63	31.24	9.12	
15	13.7	42.56	11.03	39.83	10.54	36.90	10.08	35.53	9.85	33.97	9.63	31.24	9.14	
50%	-25	-25.4	35.53	14.65	33.19	13.58	30.85	12.52	29.48	13.10	28.31	11.50	25.97	10.51
	-19.8	-20	35.53	14.39	33.19	13.34	30.85	12.30	29.48	11.82	28.31	11.31	25.97	10.34
	-18.8	-19	35.53	14.26	33.19	13.22	30.85	12.20	29.48	14.23	28.31	11.20	25.97	10.24
	-16.7	-17	35.53	13.98	33.19	12.96	30.85	11.97	29.48	11.48	28.31	11.00	25.97	10.06
	-13.7	-15	35.53	13.72	33.19	12.73	30.85	11.76	29.48	11.28	28.31	10.82	25.97	9.88
	-11.8	-13	35.53	13.47	33.19	12.50	30.85	11.56	29.48	11.08	28.31	10.62	25.97	9.73
	-9.8	-11	35.53	13.24	33.19	12.30	30.85	11.36	29.48	10.90	28.31	10.44	25.97	9.55
	-9.5	-10	35.53	13.11	33.19	12.17	30.85	11.25	29.48	10.80	28.31	10.36	25.97	9.47
	-8.5	-9.1	35.53	13.01	33.19	12.10	30.85	11.18	29.48	10.72	28.31	10.29	25.97	9.42
	-7	-7.6	35.53	12.86	33.19	11.94	30.85	11.03	29.48	10.59	28.31	10.16	25.97	9.29
	-5	-5.6	35.53	12.55	33.19	11.66	30.85	10.80	29.48	10.39	28.31	9.96	25.97	9.14
	-3	-3.7	35.53	13.01	33.19	12.10	30.85	11.20	29.48	10.77	28.31	10.34	25.97	9.47
	0	-0.7	35.53	13.70	33.19	12.73	30.85	11.82	29.48	11.36	28.31	10.90	25.97	10.01
	3	2.2	35.53	12.04	33.19	11.23	30.85	10.41	29.48	10.03	28.31	9.63	25.97	8.86
	5	4.1	35.53	11.38	33.19	10.64	30.85	9.96	29.48	9.60	28.31	9.24	25.97	8.56
	7	6	35.53	10.34	33.19	9.75	30.85	9.14	29.48	8.86	28.31	8.56	25.97	7.97
9	7.9	35.53	10.16	33.19	9.63	30.85	9.09	29.48	8.84	28.31	8.56	25.97	8.05	
11	9.8	35.53	10.01	33.19	9.52	30.85	9.04	29.48	8.81	28.31	8.58	25.97	8.10	
13	11.8	35.53	9.88	33.19	9.45	30.85	9.04	29.48	8.81	28.31	8.58	25.97	8.20	
15	13.7	35.53	9.85	33.19	9.45	30.85	9.07	29.48	8.89	28.31	8.71	25.97	8.33	

Обозначения:

CR: Индекс установленной мощности;
 ТС: Полная производительность (кВт);
 PI: Потребляемая мощность (компрессор + двигатель вентилятора наружного блока) (кВт)

Примечание: 1. В серых ячейках указаны расчётные значения.

Таблица 2-8.13: Таблица теплопроизводительности для блоков производительностью 24 л.с.

CR	Температура наружного воздуха (°C DB)		Температура в помещении °C DB											
			16.0		18.0		20.0		21.0		22.0		24.0	
			ТС	PI	ТС	PI	ТС	PI	ТС	PI	ТС	PI	ТС	PI
°C DB	°C WB	кВт	кВт	кВт	кВт	кВт	кВт	кВт	кВт	кВт	кВт	кВт	кВт	
130%	-25	-25.4	54.00	18.27	53.79	18.44	53.58	18.64	53.41	18.75	53.37	18.87	53.07	19.12
	-19.8	-20	54.94	18.30	54.72	18.49	54.51	18.67	54.30	18.79	54.30	18.91	54.09	19.16
	-18.8	-19	55.36	18.33	55.15	18.49	54.94	18.70	54.94	18.81	54.72	18.93	54.51	19.16
	-16.7	-17	56.21	18.35	56.00	18.53	55.79	18.72	55.79	18.84	55.57	18.95	55.36	19.21
	-13.7	-15	57.06	18.37	56.85	18.56	56.63	18.77	56.63	18.88	56.42	19.00	56.21	19.23
	-11.8	-13	57.91	18.42	57.69	18.60	57.48	18.79	57.48	18.91	57.27	19.02	57.27	19.28
	-9.8	-11	58.76	18.44	58.54	18.63	58.33	18.84	58.33	18.93	58.33	19.04	58.12	19.30
	-9.5	-10	59.18	18.46	58.97	18.63	58.97	18.84	58.76	18.95	58.76	19.07	58.54	19.32
	-8.5	-9.1	59.60	18.46	59.39	18.65	59.18	18.86	59.18	18.98	59.18	19.09	58.97	19.35
	-7	-7.6	60.24	18.49	60.03	18.67	60.03	18.88	59.82	19.00	59.82	19.11	59.60	19.37
	-5	-5.6	64.91	19.83	64.69	20.04	64.48	20.25	64.48	20.39	64.27	20.51	64.06	20.76
	-3	-3.7	65.75	20.88	65.54	21.11	65.33	21.34	65.33	21.46	65.12	21.60	64.91	21.87
	0	-0.7	67.03	22.55	66.82	22.80	66.60	23.06	66.60	23.17	66.39	23.31	66.39	23.61
	3	2.2	73.18	22.13	73.18	22.36	72.97	22.62	72.75	22.73	72.75	22.87	72.54	22.62
	5	4.1	92.06	27.37	91.84	27.21	86.97	24.89	83.57	23.75	80.18	22.64	73.60	20.46
	7	6	100.33	25.01	93.54	23.10	86.97	21.25	83.57	20.34	80.18	19.44	73.60	17.70
	9	7.9	100.33	22.83	93.54	21.20	86.97	19.60	83.57	18.84	80.18	18.07	73.60	16.54
11	9.8	100.33	20.92	93.54	19.51	86.97	18.16	83.57	17.51	80.18	16.84	73.60	15.52	
13	11.8	100.33	19.28	93.54	18.07	86.97	16.91	83.57	16.33	80.18	15.75	73.60	14.61	
15	13.7	100.33	18.02	93.54	16.98	86.97	15.96	83.57	15.45	80.18	14.94	73.60	13.94	
120%	-25	-25.4	54.17	19.09	53.95	19.28	112.98	19.49	53.74	19.60	53.51	19.73	53.36	19.99
	-19.8	-20	54.88	19.11	54.66	19.30	54.45	19.52	54.45	19.64	54.24	19.76	54.03	20.02
	-18.8	-19	55.30	19.13	55.09	19.33	54.88	19.54	54.88	19.64	54.66	19.78	54.45	20.02
	-16.7	-17	56.15	19.16	55.94	19.35	55.73	19.56	55.73	19.68	55.51	19.80	55.51	20.07
	-13.7	-15	57.00	19.18	56.79	19.40	56.58	19.61	56.58	19.71	56.58	19.85	56.37	20.09
	-11.8	-13	57.85	19.23	57.64	19.42	59.13	19.64	57.43	19.76	57.43	19.88	57.22	20.14
	-9.8	-11	58.70	19.25	58.49	19.45	58.49	19.66	58.28	19.78	58.28	19.90	58.07	20.16
	-9.5	-10	59.13	19.28	58.92	19.47	58.92	19.68	58.70	19.80	58.70	19.92	58.49	20.19
	-8.5	-9.1	59.56	19.28	59.34	19.49	59.34	19.71	59.13	19.83	59.13	19.95	58.92	20.19
	-7	-7.6	60.19	19.30	59.98	19.52	59.98	19.73	59.77	19.85	59.77	19.97	59.56	20.21
	-5	-5.6	64.87	20.71	64.66	20.93	64.45	21.17	64.45	21.29	64.45	21.41	64.23	21.67
	-3	-3.7	65.72	21.82	65.51	22.06	65.30	22.29	65.30	22.41	65.09	22.56	65.09	22.82
	0	-0.7	67.00	23.56	66.79	23.80	66.57	24.07	66.57	24.21	66.57	24.35	66.36	24.50
	3	2.2	73.17	23.13	73.17	23.35	72.96	23.61	72.74	23.73	72.74	23.56	68.06	21.22
	5	4.1	92.10	27.73	86.57	25.50	80.40	23.37	77.21	22.32	74.23	21.29	68.06	19.28
	7	6	92.74	23.56	86.57	21.79	80.40	20.07	77.21	19.23	74.23	18.42	68.06	16.79
	9	7.9	92.74	21.62	86.57	20.12	80.40	18.65	77.21	17.91	74.23	17.19	68.06	15.78
11	9.8	92.74	19.95	86.57	18.65	80.40	17.39	77.21	16.76	74.23	16.14	68.06	14.90	
13	11.8	92.74	18.46	86.57	17.36	80.40	16.26	77.21	15.71	74.23	15.18	68.06	14.10	
15	13.7	92.74	17.36	86.57	16.40	80.40	15.42	77.21	14.94	74.23	14.49	68.06	13.55	
110%	-25	-25.4	53.87	19.59	53.63	19.80	53.37	20.01	53.45	20.12	53.26	20.26	53.24	20.51
	-19.8	-20	54.66	19.61	54.45	19.83	54.24	20.05	54.24	20.15	54.03	20.29	54.03	20.54
	-18.8	-19	55.09	19.64	54.88	19.83	54.66	20.05	54.66	20.17	54.45	20.29	54.45	20.56
	-16.7	-17	55.94	19.66	55.73	19.88	55.51	20.10	55.51	20.22	55.51	20.34	55.30	20.59
	-13.7	-15	56.79	19.71	56.58	19.91	56.37	20.12	56.37	20.25	56.37	20.37	56.15	20.63
	-11.8	-13	57.64	19.74	57.43	19.95	57.43	20.17	57.22	20.29	57.22	20.42	57.00	20.66
	-9.8	-11	58.49	19.78	58.28	19.98	58.28	20.20	58.07	20.32	58.07	20.44	57.85	20.71
	-9.5	-10	58.92	19.78	58.92	20.00	58.70	20.22	58.49	20.34	58.49	20.46	58.28	20.71
	-8.5	-9.1	59.34	19.81	59.13	20.00	59.13	20.25	58.92	20.34	58.92	20.46	58.70	20.73
	-7	-7.6	59.98	19.83	59.77	20.03	59.77	20.27	59.56	20.37	59.56	20.49	59.34	20.76
	-5	-5.6	64.66	21.29	64.45	21.51	64.23	21.73	64.23	21.85	64.23	21.97	62.32	20.59
	-3	-3.7	65.51	22.41	65.30	22.65	65.09	22.89	65.09	23.01	65.09	23.13	62.32	21.29
	0	-0.7	66.79	24.20	66.57	24.45	66.57	24.71	66.36	24.86	66.36	24.83	62.32	22.36
	3	2.2	72.96	23.74	72.96	23.98	72.74	23.67	70.83	22.58	68.06	21.51	62.32	19.40
	5	4.1	85.08	25.32	79.34	23.33	73.81	21.41	70.83	22.89	68.06	19.54	62.32	17.75
	7	6	85.08	21.65	79.34	20.08	73.81	18.52	70.83	17.77	68.06	17.02	62.32	15.56
	9	7.9	85.08	20.03	79.34	18.64	73.81	17.31	70.83	16.65	68.06	16.00	62.32	14.74
11	9.8	85.08	18.59	79.34	17.41	73.81	16.24	70.83	15.68	68.06	15.10	62.32	13.98	
13	11.8	85.08	17.31	79.34	16.29	73.81	15.29	70.83	14.81	68.06	14.30	62.32	13.33	
15	13.7	85.08	16.39	79.34	15.49	73.81	14.59	70.83	14.15	68.06	13.74	62.32	12.87	

Обозначения:

CR: Индекс установленной мощности;

ТС: Полная производительность (кВт);

PI: Потребляемая мощность (компрессор + двигатель вентилятора наружного блока) (кВт)

Примечание: 1. В серых ячейках указаны расчётные значения.

Продолжение таблицы на следующей странице...

MVS FDC II-S

Таблица 2-8.13: Таблица теплопроизводительности для блоков производительностью 24 л.с. (продолжение)

CR	Температура наружного воздуха (°C DB)		Температура в помещении °C DB											
			16.0		18.0		20.0		21.0		22.0		24.0	
			ТС	PI	ТС	PI	ТС	PI	ТС	PI	ТС	PI	ТС	PI
°C DB	°C WB	кВт	кВт	кВт	кВт	кВт	кВт	кВт	кВт	кВт	кВт	кВт	кВт	
100%	-25	-25.4	54.45	19.91	54.24	20.10	54.03	20.32	54.03	20.44	54.03	20.56	53.81	20.83
	-19.8	-20	54.88	19.91	54.66	20.12	54.45	20.34	54.45	20.46	54.45	20.59	54.24	20.83
	-18.8	-19	55.73	19.95	55.51	20.17	55.30	20.39	55.30	20.49	55.30	20.61	55.09	20.85
	-16.7	-17	56.58	19.98	56.37	20.20	56.37	20.42	56.15	20.54	56.15	20.66	55.94	20.42
	-13.7	-15	57.43	20.03	57.22	20.22	57.22	20.46	57.00	20.56	57.00	20.68	56.79	20.00
	-11.8	-13	58.28	20.05	58.07	20.27	58.07	20.49	57.85	20.61	57.85	20.71	56.79	19.61
	-9.8	-11	58.70	20.08	58.70	20.29	58.49	20.51	58.49	20.61	58.28	20.73	56.79	19.42
	-9.5	-10	59.13	20.10	58.92	20.29	58.92	20.51	58.70	20.63	58.70	20.76	56.79	19.25
	-8.5	-9.1	59.77	20.12	59.77	20.32	59.56	20.54	59.34	20.66	59.34	20.78	56.79	18.98
	-7	-7.6	64.45	20.15	64.23	20.33	64.23	20.55	64.02	21.41	61.90	20.37	56.79	18.38
	-5	-5.6	65.30	20.17	65.09	20.34	65.09	20.56	64.45	22.14	61.90	21.07	56.79	19.01
	-3	-3.7	66.57	20.20	66.36	20.35	66.36	19.88	64.45	20.83	61.90	22.14	56.79	19.98
	0	-0.7	68.28	20.22	72.10	20.36	67.00	19.33	64.45	21.90	61.90	20.88	56.79	18.76
	3	2.2	72.74	21.49	72.10	19.86	67.00	18.77	64.45	20.15	61.90	19.23	56.79	17.38
	5	4.1	77.21	20.38	72.10	18.89	67.00	17.89	64.45	18.40	61.90	17.58	56.79	16.00
	7	6	77.21	19.26	72.10	17.92	67.00	16.75	64.45	16.09	61.90	15.41	56.79	14.13
9	7.9	77.21	18.16	72.10	16.97	67.00	15.78	64.45	15.20	61.90	14.61	56.79	13.47	
11	9.8	77.21	16.99	72.10	15.92	67.00	14.91	64.45	14.40	61.90	13.89	56.79	12.89	
13	11.8	77.21	15.92	72.10	15.03	67.00	14.13	64.45	13.69	61.90	13.25	56.79	12.38	
15	13.7	77.21	15.15	72.10	14.37	67.00	13.57	64.45	13.18	61.90	12.79	56.79	12.02	
90%	-25	-25.4	53.25	20.19	52.96	20.37	52.79	20.60	52.75	21.01	53.59	21.39	51.05	19.34
	-19.8	-20	54.24	20.22	54.03	20.42	53.81	20.63	53.81	20.76	53.81	20.88	51.05	18.93
	-18.8	-19	54.66	20.25	54.45	20.44	54.24	20.66	54.24	20.78	54.24	20.80	51.05	18.74
	-16.7	-17	55.51	20.27	55.30	20.46	55.30	20.68	55.09	20.80	55.09	20.39	51.05	18.35
	-13.7	-15	56.37	20.29	56.15	20.51	56.15	20.73	55.94	20.83	55.73	19.98	51.05	17.99
	-11.8	-13	57.22	20.34	57.00	20.54	57.00	20.76	56.79	20.56	55.73	19.57	51.05	17.65
	-9.8	-11	58.07	20.37	58.07	20.59	57.85	20.78	57.85	20.15	55.73	19.20	51.05	17.31
	-9.5	-10	58.49	20.39	58.49	20.59	58.28	20.80	58.07	19.95	55.73	19.01	51.05	17.14
	-8.5	-9.1	58.92	20.42	58.70	20.61	58.70	20.76	58.07	19.78	55.73	18.84	51.05	16.99
	-7	-7.6	59.56	20.44	59.56	20.63	59.34	20.46	58.07	19.52	55.73	18.57	51.05	16.75
	-5	-5.6	64.23	20.47	64.02	20.66	60.41	19.76	58.07	18.86	55.73	17.99	51.05	16.26
	-3	-3.7	65.09	20.50	64.87	20.68	60.41	20.44	58.07	19.52	55.73	18.62	51.05	16.82
	0	-0.7	66.36	20.53	64.87	20.70	60.41	21.48	58.07	20.51	55.73	19.57	51.05	17.70
	3	2.2	69.55	20.56	64.87	20.34	60.41	18.67	58.07	17.84	55.73	17.02	51.05	15.44
	5	4.1	69.55	20.05	64.87	18.57	60.41	17.11	58.07	16.39	55.73	15.68	51.05	14.32
	7	6	69.55	17.43	64.87	16.22	60.41	15.03	58.07	14.44	55.73	13.89	51.05	12.74
9	7.9	69.55	16.36	64.87	15.32	60.41	14.27	58.07	13.76	55.73	13.25	51.05	12.26	
11	9.8	69.55	15.41	64.87	14.49	60.41	13.59	58.07	13.13	55.73	12.70	51.05	11.82	
13	11.8	69.55	14.57	64.87	13.76	60.41	12.99	58.07	12.60	55.73	12.21	51.05	11.43	
15	13.7	69.55	13.96	64.87	13.25	60.41	12.55	58.07	12.21	55.73	11.87	51.05	11.17	
80%	-25	-25.4	53.03	20.27	52.82	20.82	53.60	20.26	51.47	19.32	49.56	18.41	45.30	16.61
	-19.8	-20	54.03	20.30	53.81	20.52	53.60	19.82	51.47	18.91	49.56	18.03	45.30	16.28
	-18.8	-19	54.45	20.33	54.24	20.52	53.60	19.63	51.47	18.72	49.56	17.83	45.30	16.11
	-16.7	-17	55.30	20.35	55.09	20.57	53.60	19.23	51.47	18.34	49.56	17.48	45.30	15.77
	-13.7	-15	56.15	20.40	55.94	20.59	53.60	18.84	51.47	17.98	49.56	17.14	45.30	15.49
	-11.8	-13	57.00	20.42	56.79	20.21	53.60	18.46	51.47	17.62	49.56	16.80	45.30	15.20
	-9.8	-11	57.85	20.45	57.64	19.80	53.60	18.12	51.47	17.28	49.56	16.49	45.30	14.91
	-9.5	-10	58.28	20.47	57.64	19.61	53.60	17.93	51.47	17.12	49.56	16.32	45.30	14.77
	-8.5	-9.1	58.70	20.50	57.64	19.44	53.60	17.79	51.47	16.97	49.56	16.18	45.30	14.65
	-7	-7.6	59.34	20.52	57.64	19.15	53.60	17.55	51.47	16.76	49.56	15.96	45.30	14.45
	-5	-5.6	61.90	20.11	57.64	18.53	53.60	17.00	51.47	16.23	49.56	15.51	45.30	14.05
	-3	-3.7	61.90	20.81	57.64	19.18	53.60	17.59	51.47	16.80	49.56	16.04	45.30	14.55
	0	-0.7	61.90	21.86	57.64	20.16	53.60	18.48	51.47	17.67	49.56	16.88	45.30	15.32
	3	2.2	61.90	18.99	57.64	17.52	53.60	16.11	51.47	15.41	49.56	14.74	45.30	13.40
	5	4.1	61.90	17.36	57.64	16.11	53.60	14.89	51.47	14.29	49.56	13.69	45.30	12.54
	7	6	61.90	15.22	57.64	14.22	53.60	13.21	51.47	12.70	49.56	12.23	45.30	11.27
9	7.9	61.90	14.43	57.64	13.54	53.60	12.66	51.47	12.23	49.56	11.77	45.30	10.93	
11	9.8	61.90	13.71	57.64	12.92	53.60	12.15	51.47	11.77	49.56	11.39	45.30	10.64	
13	11.8	61.90	13.09	57.64	12.39	53.60	11.72	51.47	11.39	49.56	11.05	45.30	10.38	
15	13.7	61.90	12.63	57.64	12.01	53.60	11.41	51.47	11.12	49.56	10.81	45.30	10.21	

Обозначения:

CR: Индекс установленной мощности;
 ТС: Полная производительность (кВт);
 PI: Потребляемая мощность (компрессор + двигатель вентилятора наружного блока) (кВт)

Примечание: 1. В серых ячейках указаны расчётные значения.

Продолжение таблицы на следующей странице...

Таблица 2-8.13: Таблица теплопроизводительности для блоков производительностью 24 л.с. (продолжение)

CR	Температура наружного воздуха (°C DB)		Температура в помещении °C DB											
			16.0		18.0		20.0		21.0		22.0		24.0	
			ТС	PI	ТС	PI	ТС	PI	ТС	PI	ТС	PI	ТС	PI
°C DB	°C WB	кВт	кВт	кВт	кВт	кВт	кВт	кВт	кВт	кВт	кВт	кВт	кВт	
70%	-25	-25.4	53.69	20.75	50.41	19.08	47.01	17.48	45.09	16.69	43.39	15.93	39.77	14.41
	-19.8	-20	53.60	20.32	50.41	18.69	47.01	17.14	45.09	16.36	43.39	15.61	39.77	14.13
	-18.8	-19	54.03	20.10	50.41	18.50	47.01	16.94	45.09	16.19	43.39	15.46	39.77	14.01
	-16.7	-17	54.03	19.69	50.41	18.13	47.01	16.63	45.09	15.88	43.39	15.15	39.77	13.74
	-13.7	-15	54.03	19.30	50.41	17.77	47.01	16.29	45.09	15.58	43.39	14.86	39.77	13.47
	-11.8	-13	54.03	18.91	50.41	17.43	47.01	16.00	45.09	15.27	43.39	14.59	39.77	13.23
	-9.8	-11	54.03	18.55	50.41	17.09	47.01	15.68	45.09	15.00	43.39	14.32	39.77	12.99
	-9.5	-10	54.03	18.38	50.41	16.94	47.01	15.54	45.09	14.86	43.39	14.18	39.77	12.89
	-8.5	-9.1	54.03	18.21	50.41	16.80	47.01	15.41	45.09	14.74	43.39	14.08	39.77	12.77
	-7	-7.6	54.03	17.96	50.41	16.56	47.01	15.20	45.09	14.54	43.39	13.89	39.77	12.60
	-5	-5.6	54.03	17.41	50.41	16.07	47.01	14.78	45.09	14.15	43.39	13.52	39.77	12.31
	-3	-3.7	54.03	18.01	50.41	16.63	47.01	15.29	45.09	14.64	43.39	14.01	39.77	12.74
	0	-0.7	54.03	18.93	50.41	17.50	47.01	16.09	45.09	15.41	43.39	14.74	39.77	13.42
	3	2.2	54.03	16.48	50.41	15.27	47.01	14.08	45.09	13.50	43.39	12.91	39.77	11.80
	5	4.1	54.03	15.22	50.41	14.18	47.01	13.13	45.09	12.62	43.39	12.11	39.77	11.12
	7	6	54.03	13.50	50.41	12.62	47.01	11.77	45.09	11.34	43.39	10.92	39.77	10.10
	9	7.9	54.03	12.91	50.41	12.14	47.01	11.39	45.09	13.45	43.39	10.63	39.77	9.90
11	9.8	54.03	12.40	50.41	11.73	47.01	11.05	45.09	10.73	43.39	10.39	39.77	9.73	
13	11.8	54.03	11.94	50.41	11.36	47.01	10.75	45.09	10.46	43.39	10.17	39.77	9.59	
15	13.7	54.03	11.63	50.41	11.09	47.01	10.58	45.09	10.32	43.39	10.05	39.77	9.54	
60%	-25	-25.4	46.37	17.28	43.39	15.93	40.20	14.63	38.71	13.99	37.01	13.37	34.03	12.16
	-19.8	-20	46.37	16.92	43.39	15.61	40.20	14.35	38.71	13.72	37.01	13.11	34.03	11.92
	-18.8	-19	46.37	16.75	43.39	15.46	40.20	14.20	38.71	13.59	37.01	12.99	34.03	11.82
	-16.7	-17	46.37	16.41	43.39	15.15	40.20	13.93	38.71	13.33	37.01	12.74	34.03	11.60
	-13.7	-15	46.37	16.09	43.39	14.86	40.20	13.67	38.71	13.08	37.01	12.53	34.03	11.39
	-11.8	-13	46.37	15.78	43.39	14.59	40.20	13.42	38.71	12.84	37.01	12.28	34.03	11.19
	-9.8	-11	46.37	15.49	43.39	14.32	40.20	13.18	38.71	12.62	37.01	12.06	34.03	11.00
	-9.5	-10	46.37	15.34	43.39	14.18	40.20	13.06	38.71	12.50	37.01	11.97	34.03	10.90
	-8.5	-9.1	46.37	15.24	43.39	14.08	40.20	12.96	38.71	12.40	37.01	11.87	34.03	10.83
	-7	-7.6	46.37	15.00	43.39	13.89	40.20	12.79	38.71	12.26	37.01	11.73	34.03	10.68
	-5	-5.6	46.37	14.59	43.39	13.52	40.20	12.48	38.71	11.97	37.01	11.46	34.03	10.46
	-3	-3.7	46.37	15.12	43.39	14.01	40.20	12.91	38.71	12.40	37.01	11.87	34.03	10.85
	0	-0.7	46.37	15.90	43.39	14.74	40.20	13.62	38.71	13.06	37.01	12.50	34.03	11.43
	3	2.2	46.37	13.91	43.39	12.91	40.20	11.94	38.71	11.48	37.01	11.00	34.03	10.07
	5	4.1	46.37	12.99	43.39	12.11	40.20	11.26	38.71	10.85	37.01	10.44	34.03	9.61
	7	6	46.37	11.65	43.39	10.92	40.20	10.22	38.71	9.86	37.01	9.52	34.03	8.84
	9	7.9	46.37	11.29	43.39	10.63	40.20	10.00	38.71	9.69	37.01	9.39	34.03	8.76
11	9.8	46.37	10.95	43.39	10.39	40.20	9.83	38.71	9.54	37.01	9.27	34.03	8.71	
13	11.8	46.37	10.68	43.39	10.17	40.20	9.69	38.71	9.42	37.01	9.18	34.03	8.69	
15	13.7	46.37	10.51	43.39	10.05	40.20	9.61	38.71	9.39	37.01	9.18	34.03	8.71	
50%	-25	-25.4	38.71	13.97	36.16	12.94	33.61	11.93	32.12	12.49	30.84	10.96	28.29	10.02
	-19.8	-20	38.71	13.72	36.16	12.72	33.61	11.73	32.12	11.26	30.84	10.78	28.29	9.86
	-18.8	-19	38.71	13.59	36.16	12.60	33.61	11.63	32.12	13.57	30.84	10.68	28.29	9.76
	-16.7	-17	38.71	13.33	36.16	12.36	33.61	11.41	32.12	10.95	30.84	10.49	28.29	9.59
	-13.7	-15	38.71	13.08	36.16	12.14	33.61	11.22	32.12	10.75	30.84	10.32	28.29	9.42
	-11.8	-13	38.71	12.84	36.16	11.92	33.61	11.02	32.12	10.56	30.84	10.12	28.29	9.27
	-9.8	-11	38.71	12.62	36.16	11.73	33.61	10.83	32.12	10.39	30.84	9.95	28.29	9.10
	-9.5	-10	38.71	12.50	36.16	11.60	33.61	10.73	32.12	10.29	30.84	9.88	28.29	9.03
	-8.5	-9.1	38.71	12.40	36.16	11.53	33.61	10.66	32.12	10.22	30.84	9.81	28.29	8.98
	-7	-7.6	38.71	12.26	36.16	11.39	33.61	10.51	32.12	10.10	30.84	9.69	28.29	8.86
	-5	-5.6	38.71	11.97	36.16	11.12	33.61	10.29	32.12	9.90	30.84	9.49	28.29	8.71
	-3	-3.7	38.71	12.40	36.16	11.53	33.61	10.68	32.12	10.27	30.84	9.86	28.29	9.03
	0	-0.7	38.71	13.06	36.16	12.14	33.61	11.26	32.12	10.83	30.84	10.39	28.29	9.54
	3	2.2	38.71	11.48	36.16	10.71	33.61	9.93	32.12	9.56	30.84	9.18	28.29	8.45
	5	4.1	38.71	10.85	36.16	10.15	33.61	9.49	32.12	9.15	30.84	8.81	28.29	8.16
	7	6	38.71	9.86	36.16	9.30	33.61	8.71	32.12	8.45	30.84	8.16	28.29	7.60
	9	7.9	38.71	9.69	36.16	9.18	33.61	8.67	32.12	8.42	30.84	8.16	28.29	7.67
11	9.8	38.71	9.54	36.16	9.08	33.61	8.62	32.12	8.40	30.84	8.18	28.29	7.72	
13	11.8	38.71	9.42	36.16	9.01	33.61	8.62	32.12	8.40	30.84	8.18	28.29	7.82	
15	13.7	38.71	9.39	36.16	9.01	33.61	8.64	32.12	8.47	30.84	8.30	28.29	7.94	

Обозначения:

CR: Индекс установленной мощности;
 ТС: Полная производительность (кВт);
 PI: Потребляемая мощность (компрессор + двигатель вентилятора наружного блока) (кВт)

Примечание: 1. В серых ячейках указаны расчётные значения.

MVS FDC II-S

Таблица 2-8.14: Таблица теплопроизводительности для блоков производительностью 26 л.с.

CR	Температура наружного воздуха (°C DB)		Температура в помещении °C DB											
			16.0		18.0		20.0		21.0		22.0		24.0	
	°C DB	°C WB	ТС	PI	ТС	PI	ТС	PI	ТС	PI	ТС	PI	ТС	PI
130%	-25	-25.4	58.84	19.66	58.61	19.84	58.38	20.05	58.19	20.18	58.15	20.30	57.82	20.57
	-19.8	-20	59.86	19.69	59.63	19.89	59.39	20.09	59.16	20.21	59.16	20.34	58.93	20.61
	-18.8	-19	60.32	19.72	60.09	19.89	59.86	20.11	59.86	20.24	59.63	20.36	59.39	20.61
	-16.7	-17	61.24	19.74	61.01	19.94	60.78	20.14	60.78	20.26	60.55	20.39	60.32	20.66
	-13.7	-15	62.17	19.77	61.94	19.96	61.71	20.19	61.71	20.31	61.47	20.44	61.24	20.69
	-11.8	-13	63.09	19.81	62.86	20.01	62.63	20.21	62.63	20.34	62.40	20.46	62.40	20.74
	-9.8	-11	64.02	19.84	63.79	20.04	63.55	20.26	63.55	20.36	63.55	20.49	63.32	20.76
	-9.5	-10	64.48	19.86	64.25	20.04	64.25	20.26	64.02	20.39	64.02	20.51	63.79	20.79
	-8.5	-9.1	64.94	19.86	64.71	20.06	64.48	20.29	64.48	20.41	64.48	20.54	64.25	20.81
	-7	-7.6	65.63	19.89	65.40	20.09	65.40	20.31	65.17	20.44	65.17	20.56	64.94	20.84
	-5	-5.6	70.72	21.34	70.49	21.56	70.26	21.79	70.26	21.94	70.03	22.06	69.79	22.34
	-3	-3.7	71.64	22.46	71.41	22.71	71.18	22.96	71.18	23.08	70.95	23.23	70.72	23.53
	0	-0.7	73.03	24.26	72.80	24.53	72.57	24.81	72.57	24.93	72.34	25.08	72.34	25.41
	3	2.2	79.73	23.81	79.73	24.06	79.50	24.33	79.27	24.46	79.27	24.61	79.04	24.33
	5	4.1	100.30	29.45	100.07	29.27	94.75	26.78	91.06	25.55	87.36	24.36	80.19	22.01
7	6	109.31	26.90	101.92	24.86	94.75	22.86	91.06	21.89	87.36	20.91	80.19	19.04	
9	7.9	109.31	24.56	101.92	22.81	94.75	21.09	91.06	20.26	87.36	19.44	80.19	17.79	
11	9.8	109.31	22.51	101.92	20.99	94.75	19.54	91.06	18.84	87.36	18.12	80.19	16.70	
13	11.8	109.31	20.74	101.92	19.44	94.75	18.19	91.06	17.57	87.36	16.95	80.19	15.72	
15	13.7	109.31	19.39	101.92	18.27	94.75	17.17	91.06	16.62	87.36	16.07	80.19	15.00	
120%	-25	-25.4	59.02	20.54	58.79	20.74	123.10	20.97	58.55	21.08	58.30	21.23	58.14	21.50
	-19.8	-20	59.79	20.56	59.56	20.76	59.33	21.00	59.33	21.13	59.10	21.25	58.86	21.54
	-18.8	-19	60.25	20.58	60.02	20.79	59.79	21.02	59.79	21.13	59.56	21.28	59.33	21.54
	-16.7	-17	61.18	20.61	60.95	20.82	60.72	21.05	60.72	21.18	60.49	21.31	60.49	21.59
	-13.7	-15	62.11	20.64	61.88	20.87	61.64	21.10	61.64	21.20	61.64	21.36	61.41	21.62
	-11.8	-13	63.03	20.69	62.80	20.89	64.43	21.13	62.57	21.25	62.57	21.38	62.34	21.67
	-9.8	-11	63.96	20.71	63.73	20.92	63.73	21.15	63.50	21.28	63.50	21.41	63.27	21.69
	-9.5	-10	64.43	20.74	64.19	20.95	64.19	21.18	63.96	21.31	63.96	21.43	63.73	21.72
	-8.5	-9.1	64.89	20.74	64.66	20.97	64.66	21.20	64.43	21.33	64.43	21.46	64.19	21.72
	-7	-7.6	65.58	20.76	65.35	21.00	65.35	21.23	65.12	21.36	65.12	21.49	64.89	21.74
	-5	-5.6	70.68	22.29	70.45	22.52	70.22	22.77	70.22	22.90	70.22	23.03	69.99	23.32
	-3	-3.7	71.61	23.47	71.38	23.73	71.15	23.99	71.15	24.11	70.91	24.27	70.91	24.55
	0	-0.7	73.00	25.35	72.77	25.61	72.54	25.89	72.54	26.05	72.54	26.20	72.30	26.36
	3	2.2	79.72	24.89	79.72	25.12	79.49	25.40	79.26	25.53	79.26	25.35	74.16	22.83
	5	4.1	100.35	29.83	94.32	27.44	87.60	25.14	84.12	24.01	80.88	22.90	74.16	20.74
7	6	101.04	25.35	94.32	23.44	87.60	21.59	84.12	20.69	80.88	19.81	74.16	18.06	
9	7.9	101.04	23.26	94.32	21.64	87.60	20.07	84.12	19.27	80.88	18.50	74.16	16.98	
11	9.8	101.04	21.46	94.32	20.07	87.60	18.70	84.12	18.03	80.88	17.36	74.16	16.02	
13	11.8	101.04	19.86	94.32	18.68	87.60	17.49	84.12	16.90	80.88	16.33	74.16	15.17	
15	13.7	101.04	18.68	94.32	17.65	87.60	16.59	84.12	16.08	80.88	15.59	74.16	14.58	
110%	-25	-25.4	58.70	21.07	58.43	21.30	58.15	21.53	58.23	21.65	58.03	21.79	58.00	22.06
	-19.8	-20	59.56	21.10	59.33	21.34	59.10	21.57	59.10	21.68	58.86	21.83	58.86	22.09
	-18.8	-19	60.02	21.13	59.79	21.34	59.56	21.57	59.56	21.70	59.33	21.83	59.33	22.12
	-16.7	-17	60.95	21.15	60.72	21.39	60.49	21.62	60.49	21.75	60.49	21.89	60.25	22.15
	-13.7	-15	61.88	21.21	61.64	21.42	61.41	21.65	61.41	21.78	61.41	21.91	61.18	22.20
	-11.8	-13	62.80	21.23	62.57	21.47	62.57	21.70	62.34	21.83	62.34	21.96	62.11	22.22
	-9.8	-11	63.73	21.28	63.50	21.49	63.50	21.73	63.27	21.86	63.27	21.99	63.03	22.28
	-9.5	-10	64.19	21.28	64.19	21.52	63.96	21.75	63.73	21.89	63.73	22.02	63.50	22.28
	-8.5	-9.1	64.66	21.31	64.43	21.52	64.43	21.78	64.19	21.89	64.19	22.02	63.96	22.30
	-7	-7.6	65.35	21.34	65.12	21.55	65.12	21.81	64.89	21.91	64.89	22.04	64.66	22.33
	-5	-5.6	70.45	22.90	70.22	23.14	69.99	23.37	69.99	23.50	69.99	23.63	67.90	22.15
	-3	-3.7	71.38	24.11	71.15	24.37	70.91	24.63	70.91	24.76	70.91	24.89	67.90	22.90
	0	-0.7	72.77	26.04	72.54	26.30	72.54	26.59	72.30	26.74	72.30	26.72	67.90	24.05
	3	2.2	79.49	25.54	79.49	25.80	79.26	25.46	77.17	24.29	74.16	23.14	67.90	20.87
	5	4.1	92.70	27.24	86.44	25.10	80.42	23.03	77.17	24.63	74.16	21.02	67.90	19.09
7	6	92.70	23.30	86.44	21.60	80.42	19.93	77.17	19.12	74.16	18.31	67.90	16.74	
9	7.9	92.70	21.55	86.44	20.06	80.42	18.62	77.17	17.92	74.16	17.21	67.90	15.85	
11	9.8	92.70	20.00	86.44	18.73	80.42	17.47	77.17	16.87	74.16	16.24	67.90	15.04	
13	11.8	92.70	18.62	86.44	17.52	80.42	16.45	77.17	15.93	74.16	15.38	67.90	14.34	
15	13.7	92.70	17.63	86.44	16.66	80.42	15.70	77.17	15.23	74.16	14.78	67.90	13.84	

Часть 2 Технические характеристики наружных блоков

Обозначения:

CR: Индекс установленной мощности;
 ТС: Полная производительность (кВт);
 PI: Потребляемая мощность (компрессор + двигатель вентилятора наружного блока) (кВт)

Примечание: 1. В серых ячейках указаны расчётные значения.

Продолжение таблицы на следующей странице...

Таблица 2-8.14: Таблица теплопроизводительности для блоков производительностью 26 л.с. (продолжение)

CR	Температура наружного воздуха (°C DB)		Температура в помещении °C DB											
			16.0		18.0		20.0		21.0		22.0		24.0	
	°C DB	°C WB	ТС	PI	ТС	PI	ТС	PI	ТС	PI	ТС	PI	ТС	PI
100%	-25	-25.4	59.33	21.42	59.10	21.62	58.86	21.86	58.86	21.99	58.86	22.12	58.63	22.41
	-19.8	-20	59.79	21.42	59.56	21.65	59.33	21.89	59.33	22.02	59.33	22.15	59.10	22.41
	-18.8	-19	60.72	21.47	60.49	21.70	60.25	21.94	60.25	22.04	60.25	22.17	60.02	22.43
	-16.7	-17	61.64	21.49	61.41	21.73	61.41	21.96	61.18	22.09	61.18	22.22	60.95	21.96
	-13.7	-15	62.57	21.55	62.34	21.75	62.34	22.02	62.11	22.12	62.11	22.25	61.88	21.52
	-11.8	-13	63.50	21.57	63.27	21.81	63.27	22.04	63.03	22.17	63.03	22.28	61.88	21.10
	-9.8	-11	63.96	21.60	63.96	21.83	63.73	22.07	63.73	22.17	63.50	22.30	61.88	20.89
	-9.5	-10	64.43	21.62	64.19	21.83	64.19	22.07	63.96	22.20	63.96	22.33	61.88	20.71
	-8.5	-9.1	65.12	21.65	65.12	21.86	64.89	22.09	64.66	22.22	64.66	22.36	61.88	20.42
	-7	-7.6	70.22	21.68	69.99	21.87	69.99	22.10	69.76	23.03	67.44	21.91	61.88	19.77
	-5	-5.6	71.15	21.70	70.91	21.88	70.91	22.12	70.22	23.82	67.44	22.67	61.88	20.45
	-3	-3.7	72.54	21.73	72.30	21.89	72.30	21.39	70.22	22.41	67.44	23.82	61.88	21.49
	0	-0.7	74.39	21.75	78.56	21.91	73.00	20.79	70.22	23.56	67.44	22.46	61.88	20.19
	3	2.2	79.26	23.12	78.56	21.36	73.00	20.20	70.22	21.68	67.44	20.68	61.88	18.70
	5	4.1	84.12	21.92	78.56	20.32	73.00	19.24	70.22	19.80	67.44	18.91	61.88	17.21
	7	6	84.12	20.72	78.56	19.27	73.00	18.02	70.22	17.31	67.44	16.58	61.88	15.20
	9	7.9	84.12	19.53	78.56	18.26	73.00	16.98	70.22	16.35	67.44	15.72	61.88	14.49
11	9.8	84.12	18.28	78.56	17.13	73.00	16.04	70.22	15.49	67.44	14.94	61.88	13.87	
13	11.8	84.12	17.13	78.56	16.17	73.00	15.20	70.22	14.73	67.44	14.26	61.88	13.32	
15	13.7	84.12	16.30	78.56	15.46	73.00	14.60	70.22	14.18	67.44	13.76	61.88	12.93	
90%	-25	-25.4	58.01	21.72	57.70	21.92	57.52	22.16	57.47	22.61	58.38	23.01	55.62	20.81
	-19.8	-20	59.10	21.75	58.86	21.96	58.63	22.20	58.63	22.33	58.63	22.46	55.62	20.37
	-18.8	-19	59.56	21.78	59.33	21.99	59.10	22.22	59.10	22.36	59.10	22.38	55.62	20.16
	-16.7	-17	60.49	21.81	60.25	22.02	60.25	22.25	60.02	22.38	60.02	21.94	55.62	19.74
	-13.7	-15	61.41	21.83	61.18	22.07	61.18	22.30	60.95	22.41	60.72	21.49	55.62	19.35
	-11.8	-13	62.34	21.89	62.11	22.09	62.11	22.33	61.88	22.12	60.72	21.05	55.62	18.99
	-9.8	-11	63.27	21.91	63.27	22.15	63.03	22.36	63.03	21.68	60.72	20.66	55.62	18.62
	-9.5	-10	63.73	21.94	63.73	22.15	63.50	22.38	63.27	21.47	60.72	20.45	55.62	18.44
	-8.5	-9.1	64.19	21.96	63.96	22.17	63.96	22.33	63.27	21.28	60.72	20.27	55.62	18.28
	-7	-7.6	64.89	21.99	64.89	22.20	64.66	22.02	63.27	21.00	60.72	19.98	55.62	18.02
	-5	-5.6	69.99	22.03	69.76	22.22	65.82	21.26	63.27	20.29	60.72	19.35	55.62	17.50
	-3	-3.7	70.91	22.06	70.68	22.25	65.82	21.99	63.27	21.00	60.72	20.03	55.62	18.10
	0	-0.7	72.30	22.09	70.68	22.27	65.82	23.11	63.27	22.07	60.72	21.05	55.62	19.04
	3	2.2	75.78	22.12	70.68	21.89	65.82	20.08	63.27	19.20	60.72	18.31	55.62	16.61
	5	4.1	75.78	21.57	70.68	19.98	65.82	18.41	63.27	17.63	60.72	16.87	55.62	15.41
	7	6	75.78	18.75	70.68	17.45	65.82	16.17	63.27	15.54	60.72	14.94	55.62	13.71
	9	7.9	75.78	17.60	70.68	16.48	65.82	15.36	63.27	14.81	60.72	14.26	55.62	13.19
11	9.8	75.78	16.58	70.68	15.59	65.82	14.62	63.27	14.13	60.72	13.66	55.62	12.72	
13	11.8	75.78	15.67	70.68	14.81	65.82	13.97	63.27	13.55	60.72	13.14	55.62	12.30	
15	13.7	75.78	15.02	70.68	14.26	65.82	13.50	63.27	13.14	60.72	12.77	55.62	12.01	
80%	-25	-25.4	57.78	21.81	57.55	22.40	58.40	21.80	56.08	20.79	54.00	19.80	49.36	17.87
	-19.8	-20	58.86	21.84	58.63	22.08	58.40	21.33	56.08	20.35	54.00	19.39	49.36	17.51
	-18.8	-19	59.33	21.87	59.10	22.08	58.40	21.12	56.08	20.14	54.00	19.19	49.36	17.33
	-16.7	-17	60.25	21.89	60.02	22.13	58.40	20.68	56.08	19.73	54.00	18.80	49.36	16.97
	-13.7	-15	61.18	21.95	60.95	22.15	58.40	20.27	56.08	19.34	54.00	18.44	49.36	16.66
	-11.8	-13	62.11	21.97	61.88	21.74	58.40	19.86	56.08	18.95	54.00	18.08	49.36	16.35
	-9.8	-11	63.03	22.00	62.80	21.30	58.40	19.50	56.08	18.59	54.00	17.74	49.36	16.04
	-9.5	-10	63.50	22.02	62.80	21.10	58.40	19.29	56.08	18.41	54.00	17.56	49.36	15.89
	-8.5	-9.1	63.96	22.05	62.80	20.91	58.40	19.14	56.08	18.26	54.00	17.41	49.36	15.76
	-7	-7.6	64.66	22.08	62.80	20.61	58.40	18.88	56.08	18.03	54.00	17.18	49.36	15.55
	-5	-5.6	67.44	21.64	62.80	19.93	58.40	18.28	56.08	17.46	54.00	16.69	49.36	15.11
	-3	-3.7	67.44	22.38	62.80	20.63	58.40	18.93	56.08	18.08	54.00	17.25	49.36	15.65
	0	-0.7	67.44	23.52	62.80	21.69	58.40	19.88	56.08	19.01	54.00	18.16	49.36	16.48
	3	2.2	67.44	20.42	62.80	18.85	58.40	17.33	56.08	16.58	54.00	15.86	49.36	14.42
	5	4.1	67.44	18.67	62.80	17.33	58.40	16.01	56.08	15.37	54.00	14.73	49.36	13.49
	7	6	67.44	16.38	62.80	15.29	58.40	14.21	56.08	13.67	54.00	13.15	49.36	12.12
	9	7.9	67.44	15.52	62.80	14.57	58.40	13.62	56.08	13.15	54.00	12.66	49.36	11.76
11	9.8	67.44	14.75	62.80	13.90	58.40	13.07	56.08	12.66	54.00	12.25	49.36	11.45	
13	11.8	67.44	14.08	62.80	13.33	58.40	12.61	56.08	12.25	54.00	11.89	49.36	11.17	
15	13.7	67.44	13.59	62.80	12.92	58.40	12.28	56.08	11.97	54.00	11.63	49.36	10.99	

Обозначения:

CR: Индекс установленной мощности;

ТС: Полная производительность (кВт);

PI: Потребляемая мощность (компрессор + двигатель вентилятора наружного блока) (кВт)

Примечание: 1. В серых ячейках указаны расчётные значения.

Продолжение таблицы на следующей странице...

MVS FDC II-S

Таблица 2-8.14: Таблица теплопроизводительности для блоков производительностью 26 л.с. (продолжение)

CR	Температура наружного воздуха (°C DB)		Температура в помещении °C DB											
			16.0		18.0		20.0		21.0		22.0		24.0	
			ТС	PI	ТС	PI	ТС	PI	ТС	PI	ТС	PI	ТС	PI
°C DB	°C WB	кВт	кВт	кВт	кВт	кВт	кВт	кВт	кВт	кВт	кВт	кВт	кВт	
70%	-25	-25.4	58.49	22.32	54.92	20.53	51.22	18.81	49.13	17.96	47.28	17.13	43.34	15.51
	-19.8	-20	58.40	21.86	54.92	20.11	51.22	18.44	49.13	17.60	47.28	16.79	43.34	15.20
	-18.8	-19	58.86	21.62	54.92	19.90	51.22	18.23	49.13	17.42	47.28	16.64	43.34	15.07
	-16.7	-17	58.86	21.18	54.92	19.51	51.22	17.89	49.13	17.08	47.28	16.30	43.34	14.78
	-13.7	-15	58.86	20.76	54.92	19.12	51.22	17.52	49.13	16.77	47.28	15.98	43.34	14.49
	-11.8	-13	58.86	20.34	54.92	18.75	51.22	17.21	49.13	16.43	47.28	15.70	43.34	14.23
	-9.8	-11	58.86	19.95	54.92	18.39	51.22	16.87	49.13	16.14	47.28	15.41	43.34	13.97
	-9.5	-10	58.86	19.77	54.92	18.23	51.22	16.71	49.13	15.98	47.28	15.25	43.34	13.87
	-8.5	-9.1	58.86	19.59	54.92	18.07	51.22	16.58	49.13	15.85	47.28	15.15	43.34	13.74
	-7	-7.6	58.86	19.33	54.92	17.81	51.22	16.35	49.13	15.64	47.28	14.94	43.34	13.55
	-5	-5.6	58.86	18.73	54.92	17.29	51.22	15.90	49.13	15.23	47.28	14.55	43.34	13.24
	-3	-3.7	58.86	19.38	54.92	17.89	51.22	16.45	49.13	15.75	47.28	15.07	43.34	13.71
	0	-0.7	58.86	20.37	54.92	18.83	51.22	17.31	49.13	16.58	47.28	15.85	43.34	14.44
	3	2.2	58.86	17.73	54.92	16.43	51.22	15.15	49.13	14.52	47.28	13.89	43.34	12.69
	5	4.1	58.86	16.37	54.92	15.25	51.22	14.13	49.13	13.58	47.28	13.03	43.34	11.96
	7	6	58.86	14.52	54.92	13.58	51.22	12.67	49.13	12.20	47.28	11.75	43.34	10.86
9	7.9	58.86	13.89	54.92	13.06	51.22	12.25	49.13	11.47	47.28	11.44	43.34	10.66	
11	9.8	58.86	13.35	54.92	12.61	51.22	11.88	49.13	11.54	47.28	11.18	43.34	10.47	
13	11.8	58.86	12.85	54.92	12.22	51.22	11.57	49.13	11.26	47.28	10.94	43.34	10.32	
15	13.7	58.86	12.51	54.92	11.93	51.22	11.39	49.13	11.10	47.28	10.81	43.34	10.26	
60%	-25	-25.4	50.52	18.59	47.28	17.14	43.80	15.74	42.18	15.05	40.32	14.39	37.08	13.08
	-19.8	-20	50.52	18.20	47.28	16.79	43.80	15.43	42.18	14.76	40.32	14.10	37.08	12.82
	-18.8	-19	50.52	18.02	47.28	16.64	43.80	15.28	42.18	14.62	40.32	13.97	37.08	12.72
	-16.7	-17	50.52	17.65	47.28	16.30	43.80	14.99	42.18	14.34	40.32	13.71	37.08	12.48
	-13.7	-15	50.52	17.31	47.28	15.98	43.80	14.70	42.18	14.08	40.32	13.48	37.08	12.25
	-11.8	-13	50.52	16.98	47.28	15.70	43.80	14.44	42.18	13.82	40.32	13.21	37.08	12.04
	-9.8	-11	50.52	16.66	47.28	15.41	43.80	14.18	42.18	13.58	40.32	12.98	37.08	11.83
	-9.5	-10	50.52	16.51	47.28	15.25	43.80	14.05	42.18	13.45	40.32	12.88	37.08	11.73
	-8.5	-9.1	50.52	16.40	47.28	15.15	43.80	13.95	42.18	13.35	40.32	12.77	37.08	11.65
	-7	-7.6	50.52	16.14	47.28	14.94	43.80	13.76	42.18	13.19	40.32	12.61	37.08	11.49
	-5	-5.6	50.52	15.70	47.28	14.55	43.80	13.42	42.18	12.88	40.32	12.33	37.08	11.26
	-3	-3.7	50.52	16.27	47.28	15.07	43.80	13.89	42.18	13.35	40.32	12.77	37.08	11.67
	0	-0.7	50.52	17.11	47.28	15.85	43.80	14.65	42.18	14.05	40.32	13.45	37.08	12.30
	3	2.2	50.52	14.96	47.28	13.89	43.80	12.85	42.18	12.35	40.32	11.83	37.08	10.84
	5	4.1	50.52	13.97	47.28	13.03	43.80	12.12	42.18	11.67	40.32	11.23	37.08	10.34
	7	6	50.52	12.54	47.28	11.75	43.80	10.99	42.18	10.60	40.32	10.24	37.08	9.51
9	7.9	50.52	12.14	47.28	11.44	43.80	10.76	42.18	10.42	40.32	10.11	37.08	9.43	
11	9.8	50.52	11.78	47.28	11.18	43.80	10.58	42.18	10.26	40.32	9.98	37.08	9.38	
13	11.8	50.52	11.49	47.28	10.94	43.80	10.42	42.18	10.13	40.32	9.87	37.08	9.35	
15	13.7	50.52	11.31	47.28	10.81	43.80	10.34	42.18	10.11	40.32	9.87	37.08	9.38	
50%	-25	-25.4	42.18	15.02	39.40	13.92	36.62	12.84	34.99	13.44	33.60	11.79	30.82	10.78
	-19.8	-20	42.18	14.76	39.40	13.68	36.62	12.61	34.99	12.12	33.60	11.60	30.82	10.60
	-18.8	-19	42.18	14.62	39.40	13.55	36.62	12.51	34.99	11.60	33.60	11.49	30.82	10.50
	-16.7	-17	42.18	14.34	39.40	13.29	36.62	12.27	34.99	11.78	33.60	11.28	30.82	10.32
	-13.7	-15	42.18	14.08	39.40	13.06	36.62	12.07	34.99	11.57	33.60	11.10	30.82	10.13
	-11.8	-13	42.18	13.82	39.40	12.82	36.62	11.86	34.99	11.36	33.60	10.89	30.82	9.98
	-9.8	-11	42.18	13.58	39.40	12.61	36.62	11.65	34.99	11.18	33.60	10.71	30.82	9.79
	-9.5	-10	42.18	13.45	39.40	12.48	36.62	11.54	34.99	11.07	33.60	10.63	30.82	9.72
	-8.5	-9.1	42.18	13.35	39.40	12.41	36.62	11.46	34.99	10.99	33.60	10.55	30.82	9.66
	-7	-7.6	42.18	13.19	39.40	12.25	36.62	11.31	34.99	10.86	33.60	10.42	30.82	9.53
	-5	-5.6	42.18	12.88	39.40	11.96	36.62	11.07	34.99	10.66	33.60	10.21	30.82	9.38
	-3	-3.7	42.18	13.35	39.40	12.41	36.62	11.49	34.99	11.05	33.60	10.60	30.82	9.72
	0	-0.7	42.18	14.05	39.40	13.06	36.62	12.12	34.99	11.65	33.60	11.18	30.82	10.26
	3	2.2	42.18	12.35	39.40	11.52	36.62	10.68	34.99	10.29	33.60	9.87	30.82	9.09
	5	4.1	42.18	11.67	39.40	10.92	36.62	10.21	34.99	9.85	33.60	9.48	30.82	8.77
	7	6	42.18	10.60	39.40	10.00	36.62	9.38	34.99	9.09	33.60	8.77	30.82	8.17
9	7.9	42.18	10.42	39.40	9.87	36.62	9.32	34.99	9.06	33.60	8.77	30.82	8.25	
11	9.8	42.18	10.26	39.40	9.77	36.62	9.27	34.99	9.04	33.60	8.80	30.82	8.30	
13	11.8	42.18	10.13	39.40	9.69	36.62	9.27	34.99	9.04	33.60	8.80	30.82	8.41	
15	13.7	42.18	10.11	39.40	9.69	36.62	9.30	34.99	9.11	33.60	8.93	30.82	8.54	

Обозначения:

CR: Индекс установленной мощности;
 ТС: Полная производительность (кВт);
 PI: Потребляемая мощность (компрессор + двигатель вентилятора наружного блока) (кВт)

Примечание: 1. В серых ячейках указаны расчётные значения.

Таблица 2-8.15: Таблица теплопроизводительности для блоков производительностью 28 л.с.

CR	Температура наружного воздуха (°C DB)		Температура в помещении °C DB											
			16.0		18.0		20.0		21.0		22.0		24.0	
	°C DB	°C WB	ТС	PI	ТС	PI	ТС	PI	ТС	PI	ТС	PI	ТС	PI
130%	-25	-25.4	63.27	23.79	63.02	24.02	62.78	24.27	62.58	24.42	62.53	24.57	62.18	24.89
	-19.8	-20	64.37	23.83	64.12	24.07	63.87	24.31	63.62	24.47	63.62	24.62	63.37	24.95
	-18.8	-19	64.86	23.86	64.62	24.07	64.37	24.34	64.37	24.50	64.12	24.65	63.87	24.95
	-16.7	-17	65.86	23.89	65.61	24.13	65.36	24.38	65.36	24.53	65.11	24.68	64.86	25.01
	-13.7	-15	66.85	23.92	66.60	24.16	66.35	24.44	66.35	24.59	66.11	24.74	65.86	25.04
	-11.8	-13	67.85	23.98	67.60	24.22	67.35	24.47	67.35	24.62	67.10	24.77	67.10	25.10
	-9.8	-11	68.84	24.01	68.59	24.25	68.34	24.53	68.34	24.65	68.34	24.80	68.09	25.13
	-9.5	-10	69.34	24.04	69.09	24.25	69.09	24.53	68.84	24.68	68.84	24.83	68.59	25.16
	-8.5	-9.1	69.83	24.04	69.59	24.28	69.34	24.56	69.34	24.71	69.34	24.86	69.09	25.19
	-7	-7.6	70.58	24.07	70.33	24.31	70.33	24.59	70.08	24.74	70.08	24.89	69.83	25.22
	-5	-5.6	76.05	25.82	75.80	26.10	75.55	26.37	75.55	26.55	75.30	26.70	75.05	27.03
	-3	-3.7	77.04	27.18	76.79	27.49	76.54	27.79	76.54	27.94	76.30	28.12	76.05	28.48
	0	-0.7	78.53	29.36	78.28	29.69	78.04	30.02	78.04	30.17	77.79	30.36	77.79	30.75
	3	2.2	85.74	28.82	85.74	29.12	85.49	29.45	85.24	29.60	85.24	29.78	84.99	29.45
	5	4.1	107.86	35.64	107.61	35.43	101.89	32.41	97.92	30.93	93.94	29.48	86.24	26.64
	7	6	117.55	32.56	109.60	30.08	101.89	27.67	97.92	26.49	93.94	25.31	86.24	23.05
	9	7.9	117.55	29.72	109.60	27.61	101.89	25.52	97.92	24.53	93.94	23.53	86.24	21.54
11	9.8	117.55	27.24	109.60	25.40	101.89	23.65	97.92	22.80	93.94	21.93	86.24	20.21	
13	11.8	117.55	25.10	109.60	23.53	101.89	22.02	97.92	21.26	93.94	20.51	86.24	19.03	
15	13.7	117.55	23.47	109.60	22.11	101.89	20.78	97.92	20.12	93.94	19.45	86.24	18.15	
120%	-25	-25.4	63.46	24.85	63.22	25.10	132.37	25.38	62.97	25.52	62.70	25.69	62.52	26.03
	-19.8	-20	64.30	24.88	64.05	25.13	63.80	25.41	63.80	25.57	63.55	25.72	63.30	26.07
	-18.8	-19	64.79	24.91	64.54	25.16	64.30	25.44	64.30	25.57	64.05	25.76	63.80	26.07
	-16.7	-17	65.79	24.95	65.54	25.19	65.29	25.48	65.29	25.63	65.04	25.79	65.04	26.13
	-13.7	-15	66.79	24.98	66.54	25.26	66.29	25.54	66.29	25.66	66.29	25.85	66.04	26.16
	-11.8	-13	67.78	25.04	67.53	25.29	69.28	25.57	67.29	25.72	67.29	25.88	67.04	26.22
	-9.8	-11	68.78	25.07	68.53	25.32	68.53	25.60	68.28	25.76	68.28	25.91	68.03	26.25
	-9.5	-10	69.28	25.10	69.03	25.35	69.03	25.63	68.78	25.79	68.78	25.94	68.53	26.29
	-8.5	-9.1	69.78	25.10	69.53	25.38	69.53	25.66	69.28	25.82	69.28	25.97	69.03	26.29
	-7	-7.6	70.53	25.13	70.28	25.41	70.28	25.69	70.03	25.85	70.03	26.01	69.78	26.32
	-5	-5.6	76.01	26.97	75.76	27.25	75.51	27.56	75.51	27.72	75.51	27.88	75.26	28.22
	-3	-3.7	77.00	28.41	76.76	28.72	76.51	29.03	76.51	29.19	76.26	29.37	76.26	29.72
	0	-0.7	78.50	30.68	78.25	30.99	78.00	31.34	78.00	31.52	78.00	31.71	77.75	31.90
	3	2.2	85.73	30.12	85.73	30.40	85.48	30.75	85.23	30.90	85.23	30.68	79.75	27.63
	5	4.1	107.91	36.11	101.43	33.21	94.20	30.43	90.46	29.06	86.97	27.72	79.75	25.10
	7	6	108.65	30.68	101.43	28.38	94.20	26.13	90.46	25.04	86.97	23.98	79.75	21.86
	9	7.9	108.65	28.16	101.43	26.19	94.20	24.29	90.46	23.32	86.97	22.39	79.75	20.55
11	9.8	108.65	25.97	101.43	24.29	94.20	22.64	90.46	21.83	86.97	21.02	79.75	19.39	
13	11.8	108.65	24.04	101.43	22.61	94.20	21.17	90.46	20.46	86.97	19.77	79.75	18.37	
15	13.7	108.65	22.61	101.43	21.36	94.20	20.08	90.46	19.46	86.97	18.86	79.75	17.65	
110%	-25	-25.4	63.12	25.50	62.84	25.78	62.53	26.05	62.62	26.20	62.40	26.38	62.37	26.70
	-19.8	-20	64.05	25.54	63.80	25.82	63.55	26.11	63.55	26.24	63.30	26.42	63.30	26.74
	-18.8	-19	64.54	25.57	64.30	25.82	64.05	26.11	64.05	26.27	63.80	26.42	63.80	26.77
	-16.7	-17	65.54	25.60	65.29	25.89	65.04	26.17	65.04	26.33	65.04	26.49	64.79	26.80
	-13.7	-15	66.54	25.67	66.29	25.92	66.04	26.20	66.04	26.36	66.04	26.52	65.79	26.87
	-11.8	-13	67.53	25.70	67.29	25.98	67.29	26.27	67.04	26.42	67.04	26.58	66.79	26.90
	-9.8	-11	68.53	25.76	68.28	26.01	68.28	26.30	68.03	26.46	68.03	26.61	67.78	26.96
	-9.5	-10	69.03	25.76	69.03	26.05	68.78	26.33	68.53	26.49	68.53	26.65	68.28	26.96
	-8.5	-9.1	69.53	25.79	69.28	26.05	69.28	26.36	69.03	26.49	69.03	26.65	68.78	26.99
	-7	-7.6	70.28	25.82	70.03	26.08	70.03	26.39	69.78	26.52	69.78	26.68	69.53	27.03
	-5	-5.6	75.76	27.72	75.51	28.01	75.26	28.29	75.26	28.45	75.26	28.61	73.02	26.80
	-3	-3.7	76.76	29.17	76.51	29.49	76.26	29.81	76.26	29.97	76.26	30.12	73.02	27.72
	0	-0.7	78.25	31.51	78.00	31.83	78.00	32.18	77.75	32.37	77.75	32.34	73.02	29.11
	3	2.2	85.48	30.91	85.48	31.23	85.23	30.82	82.99	29.40	79.75	28.01	73.02	25.26
	5	4.1	99.68	32.97	92.95	30.38	86.47	27.88	82.99	29.81	79.75	25.45	73.02	23.11
	7	6	99.68	28.19	92.95	26.14	86.47	24.12	82.99	23.14	79.75	22.16	73.02	20.26
	9	7.9	99.68	26.08	92.95	24.28	86.47	22.54	82.99	21.68	79.75	20.83	73.02	19.19
11	9.8	99.68	24.21	92.95	22.66	86.47	21.15	82.99	20.42	79.75	19.66	73.02	18.21	
13	11.8	99.68	22.54	92.95	21.21	86.47	19.91	82.99	19.28	79.75	18.62	73.02	17.35	
15	13.7	99.68	21.34	92.95	20.17	86.47	19.00	82.99	18.43	79.75	17.89	73.02	16.75	

Обозначения:

CR: Индекс установленной мощности;

ТС: Полная производительность (кВт);

PI: Потребляемая мощность (компрессор + двигатель вентилятора наружного блока) (кВт)

Примечание: 1. В серых ячейках указаны расчётные значения.

Продолжение таблицы на следующей странице...

MVS FDC II-S

Таблица 2-8.15: Таблица теплопроизводительности для блоков производительностью 28 л.с. (продолжение)

CR	Температура наружного воздуха(°C DB)		Температура в помещении °C DB											
			16.0		18.0		20.0		21.0		22.0		24.0	
			ТС	PI	ТС	PI	ТС	PI	ТС	PI	ТС	PI	ТС	PI
°C DB	°C WB	кВт	кВт	кВт	кВт	кВт	кВт	кВт	кВт	кВт	кВт	кВт	кВт	
100%	-25	-25.4	63.80	25.92	63.55	26.17	63.30	26.46	63.30	26.61	63.30	26.77	63.05	27.12
	-19.8	-20	64.30	25.92	64.05	26.20	63.80	26.49	63.80	26.65	63.80	26.80	63.55	27.12
	-18.8	-19	65.29	25.98	65.04	26.27	64.79	26.55	64.79	26.68	64.79	26.84	64.54	27.15
	-16.7	-17	66.29	26.01	66.04	26.30	66.04	26.58	65.79	26.74	65.79	26.90	65.54	26.58
	-13.7	-15	67.29	26.08	67.04	26.33	67.04	26.65	66.79	26.77	66.79	26.93	66.54	26.05
	-11.8	-13	68.28	26.11	68.03	26.39	68.03	26.68	67.78	26.84	67.78	26.96	66.54	25.54
	-9.8	-11	68.78	26.14	68.78	26.42	68.53	26.71	68.53	26.84	68.28	26.99	66.54	25.29
	-9.5	-10	69.28	26.17	69.03	26.42	69.03	26.71	68.78	26.87	68.78	27.03	66.54	25.07
	-8.5	-9.1	70.03	26.20	70.03	26.46	69.78	26.74	69.53	26.90	69.53	27.06	66.54	24.72
	-7	-7.6	75.51	26.24	75.26	26.47	75.26	26.75	75.01	27.88	72.52	26.52	66.54	23.93
	-5	-5.6	76.51	26.27	76.26	26.48	76.26	26.77	75.51	28.83	72.52	27.44	66.54	24.75
	-3	-3.7	78.00	26.30	77.75	26.50	77.75	25.89	75.51	27.12	72.52	28.83	66.54	26.01
	0	-0.7	80.00	26.33	84.48	26.51	78.50	25.17	75.51	28.51	72.52	27.18	66.54	24.43
	3	2.2	85.23	27.98	84.48	25.86	78.50	24.45	75.51	26.24	72.52	25.03	66.54	22.63
	5	4.1	90.46	26.53	84.48	24.59	78.50	23.29	75.51	23.96	72.52	22.88	66.54	20.83
	7	6	90.46	25.08	84.48	23.33	78.50	21.81	75.51	20.96	72.52	20.07	66.54	18.40
	9	7.9	90.46	23.64	84.48	22.09	78.50	20.55	75.51	19.79	72.52	19.03	66.54	17.54
11	9.8	90.46	22.13	84.48	20.74	78.50	19.41	75.51	18.74	72.52	18.08	66.54	16.78	
13	11.8	90.46	20.74	84.48	19.57	78.50	18.40	75.51	17.83	72.52	17.26	66.54	16.12	
15	13.7	90.46	19.72	84.48	18.71	78.50	17.67	75.51	17.16	72.52	16.66	66.54	15.65	
90%	-25	-25.4	62.38	26.28	62.05	26.53	61.85	26.82	61.80	27.36	62.78	27.85	59.81	25.18
	-19.8	-20	63.55	26.33	63.30	26.58	63.05	26.87	63.05	27.03	63.05	27.18	59.81	24.65
	-18.8	-19	64.05	26.36	63.80	26.61	63.55	26.90	63.55	27.06	63.55	27.09	59.81	24.40
	-16.7	-17	65.04	26.39	64.79	26.65	64.79	26.93	64.54	27.09	64.54	26.55	59.81	23.90
	-13.7	-15	66.04	26.42	65.79	26.71	65.79	26.99	65.54	27.12	65.29	26.01	59.81	23.42
	-11.8	-13	67.04	26.49	66.79	26.74	66.79	27.03	66.54	26.77	65.29	25.48	59.81	22.98
	-9.8	-11	68.03	26.52	68.03	26.80	67.78	27.06	67.78	26.24	65.29	25.00	59.81	22.54
	-9.5	-10	68.53	26.55	68.53	26.80	68.28	27.09	68.03	25.98	65.29	24.75	59.81	22.32
	-8.5	-9.1	69.03	26.58	68.78	26.84	68.78	27.03	68.03	25.76	65.29	24.53	59.81	22.13
	-7	-7.6	69.78	26.61	69.78	26.87	69.53	26.65	68.03	25.41	65.29	24.18	59.81	21.81
	-5	-5.6	75.26	26.66	75.01	26.90	70.77	25.73	68.03	24.56	65.29	23.42	59.81	21.18
	-3	-3.7	76.26	26.70	76.01	26.92	70.77	26.61	68.03	25.41	65.29	24.24	59.81	21.90
	0	-0.7	77.75	26.73	76.01	26.95	70.77	27.97	68.03	26.71	65.29	25.48	59.81	23.04
	3	2.2	81.49	26.77	76.01	26.49	70.77	24.31	68.03	23.23	65.29	22.16	59.81	20.10
	5	4.1	81.49	26.11	76.01	24.18	70.77	22.28	68.03	21.34	65.29	20.42	59.81	18.65
	7	6	81.49	22.70	76.01	21.11	70.77	19.57	68.03	18.81	65.29	18.08	59.81	16.59
	9	7.9	81.49	21.30	76.01	19.95	70.77	18.59	68.03	17.92	65.29	17.26	59.81	15.96
11	9.8	81.49	20.07	76.01	18.87	70.77	17.70	68.03	17.10	65.29	16.53	59.81	15.39	
13	11.8	81.49	18.97	76.01	17.92	70.77	16.91	68.03	16.40	65.29	15.90	59.81	14.89	
15	13.7	81.49	18.18	76.01	17.26	70.77	16.34	68.03	15.90	65.29	15.46	59.81	14.54	
80%	-25	-25.4	62.14	26.39	61.89	27.11	62.80	26.38	60.31	25.16	58.07	23.97	53.08	21.63
	-19.8	-20	63.30	26.44	63.05	26.72	62.80	25.81	60.31	24.63	58.07	23.47	53.08	21.19
	-18.8	-19	63.80	26.47	63.55	26.72	62.80	25.56	60.31	24.38	58.07	23.22	53.08	20.98
	-16.7	-17	64.79	26.50	64.54	26.78	62.80	25.03	60.31	23.88	58.07	22.75	53.08	20.54
	-13.7	-15	65.79	26.56	65.54	26.81	62.80	24.53	60.31	23.41	58.07	22.32	53.08	20.16
	-11.8	-13	66.79	26.59	66.54	26.31	62.80	24.03	60.31	22.94	58.07	21.88	53.08	19.79
	-9.8	-11	67.78	26.62	67.53	25.78	62.80	23.60	60.31	22.50	58.07	21.47	53.08	19.41
	-9.5	-10	68.28	26.66	67.53	25.53	62.80	23.35	60.31	22.29	58.07	21.26	53.08	19.23
	-8.5	-9.1	68.78	26.69	67.53	25.31	62.80	23.16	60.31	22.10	58.07	21.07	53.08	19.07
	-7	-7.6	69.53	26.72	67.53	24.94	62.80	22.85	60.31	21.82	58.07	20.79	53.08	18.82
	-5	-5.6	72.52	26.19	67.53	24.13	62.80	22.13	60.31	21.13	58.07	20.19	53.08	18.29
	-3	-3.7	72.52	27.09	67.53	24.97	62.80	22.91	60.31	21.88	58.07	20.88	53.08	18.95
	0	-0.7	72.52	28.47	67.53	26.25	62.80	24.07	60.31	23.00	58.07	21.97	53.08	19.95
	3	2.2	72.52	24.72	67.53	22.82	62.80	20.98	60.31	20.07	58.07	19.20	53.08	17.45
	5	4.1	72.52	22.60	67.53	20.98	62.80	19.38	60.31	18.60	58.07	17.82	53.08	16.32
	7	6	72.52	19.82	67.53	18.51	62.80	17.20	60.31	16.54	58.07	15.92	53.08	14.67
	9	7.9	72.52	18.79	67.53	17.64	62.80	16.48	60.31	15.92	58.07	15.33	53.08	14.23
11	9.8	72.52	17.85	67.53	16.82	62.80	15.82	60.31	15.33	58.07	14.83	53.08	13.86	
13	11.8	72.52	17.04	67.53	16.14	62.80	15.26	60.31	14.83	58.07	14.39	53.08	13.52	
15	13.7	72.52	16.45	67.53	15.64	62.80	14.86	60.31	14.48	58.07	14.08	53.08	13.30	

Часть 2 Технические характеристики наружных блоков

Обозначения:

CR: Индекс установленной мощности;
 ТС: Полная производительность (кВт);
 PI: Потребляемая мощность (компрессор + двигатель вентилятора наружного блока) (кВт)

Примечание: 1. В серых ячейках указаны расчётные значения.

Продолжение таблицы на следующей странице...

Таблица 2-8.15: Таблица теплопроизводительности для блоков производительностью 28 л.с. (продолжение)

CR	Температура наружного воздуха (°C DB)		Температура в помещении °C DB											
			16.0		18.0		20.0		21.0		22.0		24.0	
	°C DB	°C WB	ТС	PI	ТС	PI	ТС	PI	ТС	PI	ТС	PI	ТС	PI
70%	-25	-25.4	62.90	27.02	59.06	24.84	55.07	22.76	52.83	21.74	50.84	20.74	46.60	18.77
	-19.8	-20	62.80	26.46	59.06	24.34	55.07	22.32	52.83	21.30	50.84	20.32	46.60	18.40
	-18.8	-19	63.30	26.17	59.06	24.09	55.07	22.06	52.83	21.08	50.84	20.13	46.60	18.24
	-16.7	-17	63.30	25.63	59.06	23.61	55.07	21.65	52.83	20.67	50.84	19.72	46.60	17.89
	-13.7	-15	63.30	25.13	59.06	23.14	55.07	21.21	52.83	20.29	50.84	19.34	46.60	17.54
	-11.8	-13	63.30	24.62	59.06	22.70	55.07	20.83	52.83	19.88	50.84	19.00	46.60	17.23
	-9.8	-11	63.30	24.15	59.06	22.25	55.07	20.42	52.83	19.53	50.84	18.65	46.60	16.91
	-9.5	-10	63.30	23.93	59.06	22.06	55.07	20.23	52.83	19.34	50.84	18.46	46.60	16.78
	-8.5	-9.1	63.30	23.71	59.06	21.87	55.07	20.07	52.83	19.19	50.84	18.33	46.60	16.63
	-7	-7.6	63.30	23.39	59.06	21.56	55.07	19.79	52.83	18.93	50.84	18.08	46.60	16.40
	-5	-5.6	63.30	22.66	59.06	20.92	55.07	19.25	52.83	18.43	50.84	17.61	46.60	16.03
	-3	-3.7	63.30	23.45	59.06	21.65	55.07	19.91	52.83	19.06	50.84	18.24	46.60	16.59
	0	-0.7	63.30	24.65	59.06	22.79	55.07	20.96	52.83	20.07	50.84	19.19	46.60	17.48
	3	2.2	63.30	21.46	59.06	19.88	55.07	18.33	52.83	17.57	50.84	16.82	46.60	15.36
	5	4.1	63.30	19.82	59.06	18.46	55.07	17.10	52.83	16.44	50.84	15.77	46.60	14.48
7	6	63.30	17.57	59.06	16.44	55.07	15.33	52.83	14.76	50.84	14.22	46.60	13.15	
9	7.9	63.30	16.82	59.06	15.80	55.07	14.82	52.83	17.51	50.84	13.84	46.60	12.90	
11	9.8	63.30	16.15	59.06	15.27	55.07	14.38	52.83	13.97	50.84	13.53	46.60	12.68	
13	11.8	63.30	15.55	59.06	14.79	55.07	14.00	52.83	13.62	50.84	13.24	46.60	12.49	
15	13.7	63.30	15.14	59.06	14.45	55.07	13.78	52.83	13.43	50.84	13.09	46.60	12.42	
60%	-25	-25.4	54.33	22.50	50.84	20.75	47.10	19.06	45.36	18.22	43.36	17.41	39.87	15.83
	-19.8	-20	54.33	22.03	50.84	20.32	47.10	18.68	45.36	17.86	43.36	17.07	39.87	15.52
	-18.8	-19	54.33	21.81	50.84	20.13	47.10	18.49	45.36	17.70	43.36	16.91	39.87	15.39
	-16.7	-17	54.33	21.37	50.84	19.72	47.10	18.14	45.36	17.35	43.36	16.59	39.87	15.11
	-13.7	-15	54.33	20.96	50.84	19.34	47.10	17.80	45.36	17.04	43.36	16.31	39.87	14.82
	-11.8	-13	54.33	20.55	50.84	19.00	47.10	17.48	45.36	16.72	43.36	15.99	39.87	14.57
	-9.8	-11	54.33	20.17	50.84	18.65	47.10	17.16	45.36	16.44	43.36	15.71	39.87	14.32
	-9.5	-10	54.33	19.98	50.84	18.46	47.10	17.01	45.36	16.28	43.36	15.58	39.87	14.19
	-8.5	-9.1	54.33	19.84	50.84	18.33	47.10	16.88	45.36	16.15	43.36	15.46	39.87	14.10
	-7	-7.6	54.33	19.53	50.84	18.08	47.10	16.66	45.36	15.96	43.36	15.27	39.87	13.91
	-5	-5.6	54.33	19.00	50.84	17.61	47.10	16.25	45.36	15.58	43.36	14.92	39.87	13.62
	-3	-3.7	54.33	19.69	50.84	18.24	47.10	16.82	45.36	16.15	43.36	15.46	39.87	14.13
	0	-0.7	54.33	20.70	50.84	19.19	47.10	17.73	45.36	17.01	43.36	16.28	39.87	14.89
	3	2.2	54.33	18.11	50.84	16.82	47.10	15.55	45.36	14.95	43.36	14.32	39.87	13.12
	5	4.1	54.33	16.91	50.84	15.77	47.10	14.67	45.36	14.13	43.36	13.59	39.87	12.52
7	6	54.33	15.17	50.84	14.22	47.10	13.31	45.36	12.83	43.36	12.39	39.87	11.51	
9	7.9	54.33	14.70	50.84	13.84	47.10	13.02	45.36	12.61	43.36	12.23	39.87	11.41	
11	9.8	54.33	14.26	50.84	13.53	47.10	12.80	45.36	12.42	43.36	12.07	39.87	11.35	
13	11.8	54.33	13.91	50.84	13.24	47.10	12.61	45.36	12.26	43.36	11.95	39.87	11.32	
15	13.7	54.33	13.69	50.84	13.09	47.10	12.52	45.36	12.23	43.36	11.95	39.87	11.35	
50%	-25	-25.4	45.36	18.18	42.37	16.85	39.37	15.54	37.63	16.26	36.13	14.27	33.14	13.05
	-19.8	-20	45.36	17.86	42.37	16.56	39.37	15.27	37.63	14.67	36.13	14.03	33.14	12.83
	-18.8	-19	45.36	17.70	42.37	16.40	39.37	15.14	37.63	17.67	36.13	13.91	33.14	12.71
	-16.7	-17	45.36	17.35	42.37	16.09	39.37	14.86	37.63	14.26	36.13	13.65	33.14	12.49
	-13.7	-15	45.36	17.04	42.37	15.80	39.37	14.60	37.63	14.00	36.13	13.43	33.14	12.26
	-11.8	-13	45.36	16.72	42.37	15.52	39.37	14.35	37.63	13.75	36.13	13.18	33.14	12.07
	-9.8	-11	45.36	16.44	42.37	15.27	39.37	14.10	37.63	13.53	36.13	12.96	33.14	11.85
	-9.5	-10	45.36	16.28	42.37	15.11	39.37	13.97	37.63	13.40	36.13	12.86	33.14	11.76
	-8.5	-9.1	45.36	16.15	42.37	15.01	39.37	13.88	37.63	13.31	36.13	12.77	33.14	11.70
	-7	-7.6	45.36	15.96	42.37	14.82	39.37	13.69	37.63	13.15	36.13	12.61	33.14	11.54
	-5	-5.6	45.36	15.58	42.37	14.48	39.37	13.40	37.63	12.90	36.13	12.36	33.14	11.35
	-3	-3.7	45.36	16.15	42.37	15.01	39.37	13.91	37.63	13.37	36.13	12.83	33.14	11.76
	0	-0.7	45.36	17.01	42.37	15.80	39.37	14.67	37.63	14.10	36.13	13.53	33.14	12.42
	3	2.2	45.36	14.95	42.37	13.94	39.37	12.93	37.63	12.45	36.13	11.95	33.14	11.00
	5	4.1	45.36	14.13	42.37	13.21	39.37	12.36	37.63	11.92	36.13	11.47	33.14	10.62
7	6	45.36	12.83	42.37	12.11	39.37	11.35	37.63	11.00	36.13	10.62	33.14	9.89	
9	7.9	45.36	12.61	42.37	11.95	39.37	11.28	37.63	10.97	36.13	10.62	33.14	9.99	
11	9.8	45.36	12.42	42.37	11.82	39.37	11.22	37.63	10.94	36.13	10.65	33.14	10.05	
13	11.8	45.36	12.26	42.37	11.73	39.37	11.22	37.63	10.94	36.13	10.65	33.14	10.18	
15	13.7	45.36	12.23	42.37	11.73	39.37	11.25	37.63	11.03	36.13	10.81	33.14	10.34	

Обозначения:

- CR: Индекс установленной мощности;
- ТС: Полная производительность (кВт);
- PI: Потребляемая мощность (компрессор + двигатель вентилятора наружного блока) (кВт)

Примечание: 1. В серых ячейках указаны расчётные значения.

MVS FDC II-S

Таблица 2-8.16: Таблица теплопроизводительности для блоков производительностью 30 л.с.

CR	Температура наружного воздуха (°C DB)		Температура в помещении °C DB											
			16.0		18.0		20.0		21.0		22.0		24.0	
	°C DB	°C WB	ТС	PI	ТС	PI	ТС	PI	ТС	PI	ТС	PI	ТС	PI
130%	-25	-25.4	68.51	26.48	68.24	26.74	67.97	27.02	67.76	27.19	67.70	27.35	67.33	27.71
	-19.8	-20	69.70	26.53	69.43	26.80	69.16	27.07	68.89	27.24	68.89	27.40	68.62	27.77
	-18.8	-19	70.23	26.56	69.97	26.80	69.70	27.10	69.70	27.27	69.43	27.44	69.16	27.77
	-16.7	-17	71.31	26.60	71.04	26.87	70.77	27.14	70.77	27.30	70.50	27.47	70.23	27.84
	-13.7	-15	72.39	26.63	72.12	26.90	71.85	27.20	71.85	27.37	71.58	27.54	71.31	27.88
	-11.8	-13	73.46	26.70	73.19	26.97	72.93	27.24	72.93	27.40	72.66	27.57	72.66	27.94
	-9.8	-11	74.54	26.73	74.27	27.00	74.00	27.30	74.00	27.44	74.00	27.61	73.73	27.98
	-9.5	-10	75.08	26.77	74.81	27.00	74.81	27.30	74.54	27.47	74.54	27.64	74.27	28.01
	-8.5	-9.1	75.62	26.77	75.35	27.03	75.08	27.34	75.08	27.51	75.08	27.67	74.81	28.04
	-7	-7.6	76.42	26.80	76.15	27.07	76.15	27.37	75.89	27.54	75.89	27.71	75.62	28.08
	-5	-5.6	82.34	28.75	82.07	29.05	81.81	29.35	81.81	29.56	81.54	29.72	81.27	30.09
	-3	-3.7	83.42	30.26	83.15	30.60	82.88	30.94	82.88	31.10	82.61	31.31	82.34	31.71
	0	-0.7	85.03	32.68	84.77	33.05	84.50	33.42	84.50	33.59	84.23	33.79	84.23	34.23
	3	2.2	92.84	32.08	92.84	32.41	92.57	32.78	92.30	32.95	92.30	33.15	92.03	32.78
	5	4.1	116.79	39.68	116.52	39.44	110.33	36.08	106.02	34.43	101.72	32.82	93.38	29.66
7	6	127.28	36.25	118.67	33.49	110.33	30.80	106.02	29.49	101.72	28.18	93.38	25.66	
9	7.9	127.28	33.09	118.67	30.73	110.33	28.41	106.02	27.30	101.72	26.19	93.38	23.97	
11	9.8	127.28	30.33	118.67	28.28	110.33	26.33	106.02	25.39	101.72	24.41	93.38	22.50	
13	11.8	127.28	27.94	118.67	26.19	110.33	24.51	106.02	23.67	101.72	22.83	93.38	21.18	
15	13.7	127.28	26.13	118.67	24.61	110.33	23.13	106.02	22.39	101.72	21.65	93.38	20.21	
120%	-25	-25.4	68.72	27.67	68.45	27.94	143.33	28.25	68.18	28.41	67.89	28.60	67.69	28.98
	-19.8	-20	69.62	27.70	69.35	27.98	69.08	28.29	69.08	28.46	68.81	28.64	68.54	29.02
	-18.8	-19	70.16	27.74	69.89	28.01	69.62	28.33	69.62	28.46	69.35	28.67	69.08	29.02
	-16.7	-17	71.24	27.77	70.97	28.05	70.70	28.36	70.70	28.53	70.43	28.71	70.43	29.09
	-13.7	-15	72.32	27.81	72.05	28.12	71.78	28.43	71.78	28.57	71.78	28.78	71.51	29.12
	-11.8	-13	73.40	27.87	73.13	28.15	75.02	28.46	72.86	28.64	72.86	28.81	72.59	29.19
	-9.8	-11	74.48	27.91	74.21	28.19	74.21	28.50	73.94	28.67	73.94	28.85	73.67	29.23
	-9.5	-10	75.02	27.94	74.75	28.22	74.75	28.53	74.48	28.71	74.48	28.88	74.21	29.26
	-8.5	-9.1	75.56	27.94	75.29	28.26	75.29	28.57	75.02	28.74	75.02	28.92	74.75	29.26
	-7	-7.6	76.37	27.98	76.10	28.29	76.10	28.60	75.83	28.78	75.83	28.95	75.56	29.30
	-5	-5.6	82.30	30.03	82.03	30.34	81.76	30.69	81.76	30.86	81.76	31.03	81.49	31.42
	-3	-3.7	83.38	31.62	83.11	31.97	82.84	32.32	82.84	32.49	82.57	32.70	82.57	33.08
	0	-0.7	85.00	34.16	84.73	34.50	84.46	34.89	84.46	35.09	84.46	35.30	84.19	35.51
	3	2.2	92.83	33.53	92.83	33.85	92.56	34.23	92.29	34.40	92.29	34.16	86.35	30.76
	5	4.1	116.84	40.20	109.83	36.97	102.00	33.88	97.95	32.35	94.17	30.86	86.35	27.94
7	6	117.65	34.16	109.83	31.59	102.00	29.09	97.95	27.87	94.17	26.69	86.35	24.33	
9	7.9	117.65	31.35	109.83	29.16	102.00	27.04	97.95	25.97	94.17	24.92	86.35	22.88	
11	9.8	117.65	28.92	109.83	27.04	102.00	25.20	97.95	24.30	94.17	23.40	86.35	21.59	
13	11.8	117.65	26.76	109.83	25.17	102.00	23.57	97.95	22.77	94.17	22.01	86.35	20.45	
15	13.7	117.65	25.17	109.83	23.78	102.00	22.36	97.95	21.66	94.17	21.00	86.35	19.65	
110%	-25	-25.4	68.35	28.39	68.04	28.70	67.71	29.00	67.81	29.17	67.57	29.36	67.54	29.73
	-19.8	-20	69.35	28.43	69.08	28.75	68.81	29.07	68.81	29.21	68.54	29.42	68.54	29.77
	-18.8	-19	69.89	28.47	69.62	28.75	69.35	29.07	69.35	29.24	69.08	29.42	69.08	29.80
	-16.7	-17	70.97	28.50	70.70	28.82	70.43	29.14	70.43	29.31	70.43	29.49	70.16	29.84
	-13.7	-15	72.05	28.57	71.78	28.85	71.51	29.17	71.51	29.35	71.51	29.52	71.24	29.91
	-11.8	-13	73.13	28.61	72.86	28.92	72.86	29.24	72.59	29.42	72.59	29.59	72.32	29.95
	-9.8	-11	74.21	28.68	73.94	28.96	73.94	29.28	73.67	29.45	73.67	29.63	73.40	30.02
	-9.5	-10	74.75	28.68	74.75	29.00	74.48	29.31	74.21	29.49	74.21	29.66	73.94	30.02
	-8.5	-9.1	75.29	28.71	75.02	29.00	75.02	29.35	74.75	29.49	74.75	29.66	74.48	30.05
	-7	-7.6	76.10	28.75	75.83	29.03	75.83	29.38	75.56	29.52	75.56	29.70	75.29	30.09
	-5	-5.6	82.03	30.86	81.76	31.18	81.49	31.49	81.49	31.67	81.49	31.85	79.06	29.84
	-3	-3.7	83.11	32.48	82.84	32.83	82.57	33.18	82.57	33.36	82.57	33.53	79.06	30.86
	0	-0.7	84.73	35.08	84.46	35.43	84.46	35.82	84.19	36.03	84.19	36.00	79.06	32.41
	3	2.2	92.56	34.41	92.56	34.77	92.29	34.31	89.86	32.73	86.35	31.18	79.06	28.12
	5	4.1	107.94	36.70	100.65	33.82	93.63	31.04	89.86	33.18	86.35	28.33	79.06	25.72
7	6	107.94	31.39	100.65	29.10	93.63	26.85	89.86	25.76	86.35	24.67	79.06	22.56	
9	7.9	107.94	29.03	100.65	27.02	93.63	25.09	89.86	24.14	86.35	23.19	79.06	21.36	
11	9.8	107.94	26.95	100.65	25.23	93.63	23.54	89.86	22.73	86.35	21.89	79.06	20.27	
13	11.8	107.94	25.09	100.65	23.61	93.63	22.17	89.86	21.46	86.35	20.73	79.06	19.32	
15	13.7	107.94	23.75	100.65	22.45	93.63	21.15	89.86	20.51	86.35	19.92	79.06	18.65	

Обозначения:

CR: Индекс установленной мощности;
 ТС: Полная производительность (кВт);
 PI: Потребляемая мощность (компрессор + двигатель вентилятора наружного блока) (кВт)

Примечание: 1. В серых ячейках указаны расчётные значения.

Продолжение таблицы на следующей странице...

Таблица 2-8.16: Таблица теплопроизводительности для блоков производительностью 30 л.с. (продолжение)

CR	Температура наружного воздуха (°C DB)		Температура в помещении °C DB											
			16.0		18.0		20.0		21.0		22.0		24.0	
	°C DB	°C WB	ТС	PI	ТС	PI	ТС	PI	ТС	PI	ТС	PI	ТС	PI
			кВт	кВт	кВт	кВт	кВт	кВт	кВт	кВт	кВт	кВт	кВт	кВт
100%	-25	-25.4	69.08	28.85	68.81	29.14	68.54	29.45	68.54	29.63	68.54	29.80	68.27	30.19
	-19.8	-20	69.62	28.85	69.35	29.17	69.08	29.49	69.08	29.66	69.08	29.84	68.81	30.19
	-18.8	-19	70.70	28.92	70.43	29.24	70.16	29.56	70.16	29.70	70.16	29.87	69.89	30.23
	-16.7	-17	71.78	28.96	71.51	29.28	71.51	29.59	71.24	29.77	71.24	29.95	70.97	29.59
	-13.7	-15	72.86	29.03	72.59	29.31	72.59	29.66	72.32	29.80	72.32	29.98	72.05	29.00
	-11.8	-13	73.94	29.07	73.67	29.38	73.67	29.70	73.40	29.87	73.40	30.02	72.05	28.43
	-9.8	-11	74.48	29.10	74.48	29.42	74.21	29.73	74.21	29.87	73.94	30.05	72.05	28.15
	-9.5	-10	75.02	29.14	74.75	29.42	74.75	29.73	74.48	29.91	74.48	30.09	72.05	27.90
	-8.5	-9.1	75.83	29.17	75.83	29.45	75.56	29.77	75.29	29.95	75.29	30.12	72.05	27.52
	-7	-7.6	81.76	29.21	81.49	29.46	81.49	29.78	81.22	31.04	78.52	29.52	72.05	26.64
	-5	-5.6	82.84	29.24	82.57	29.48	82.57	29.80	81.76	32.09	78.52	30.54	72.05	27.55
	-3	-3.7	84.46	29.28	84.19	29.50	84.19	28.82	81.76	30.19	78.52	32.09	72.05	28.96
	0	-0.7	86.62	29.31	91.48	29.52	85.00	28.02	81.76	31.74	78.52	30.26	72.05	27.20
	3	2.2	92.29	31.15	91.48	28.78	85.00	27.21	81.76	29.21	78.52	27.87	72.05	25.19
	5	4.1	97.95	29.53	91.48	27.38	85.00	25.93	81.76	26.67	78.52	25.48	72.05	23.19
	7	6	97.95	27.92	91.48	25.97	85.00	24.28	81.76	23.33	78.52	22.34	72.05	20.48
9	7.9	97.95	26.32	91.48	24.60	85.00	22.87	81.76	22.03	78.52	21.18	72.05	19.53	
11	9.8	97.95	24.63	91.48	23.08	85.00	21.61	81.76	20.87	78.52	20.13	72.05	18.69	
13	11.8	97.95	23.08	91.48	21.78	85.00	20.48	81.76	19.85	78.52	19.21	72.05	17.95	
15	13.7	97.95	21.96	91.48	20.83	85.00	19.67	81.76	19.11	78.52	18.54	72.05	17.42	
90%	-25	-25.4	67.55	29.26	67.19	29.53	66.97	29.86	66.92	30.46	67.98	31.00	64.76	28.03
	-19.8	-20	68.81	29.31	68.54	29.59	68.27	29.91	68.27	30.09	68.27	30.26	64.76	27.45
	-18.8	-19	69.35	29.35	69.08	29.63	68.81	29.95	68.81	30.12	68.81	30.16	64.76	27.17
	-16.7	-17	70.43	29.38	70.16	29.66	70.16	29.98	69.89	30.16	69.89	29.56	64.76	26.60
	-13.7	-15	71.51	29.42	71.24	29.73	71.24	30.05	70.97	30.19	70.70	28.96	64.76	26.07
	-11.8	-13	72.59	29.49	72.32	29.77	72.32	30.09	72.05	29.80	70.70	28.36	64.76	25.58
	-9.8	-11	73.67	29.52	73.67	29.84	73.40	30.12	73.40	29.21	70.70	27.83	64.76	25.09
	-9.5	-10	74.21	29.56	74.21	29.84	73.94	30.16	73.67	28.92	70.70	27.55	64.76	24.84
	-8.5	-9.1	74.75	29.59	74.48	29.87	74.48	30.09	73.67	28.68	70.70	27.31	64.76	24.63
	-7	-7.6	75.56	29.63	75.56	29.91	75.29	29.66	73.67	28.29	70.70	26.92	64.76	24.28
	-5	-5.6	81.49	29.68	81.22	29.94	76.63	28.64	73.67	27.34	70.70	26.07	64.76	23.58
	-3	-3.7	82.57	29.72	82.30	29.97	76.63	29.63	73.67	28.29	70.70	26.99	64.76	24.39
	0	-0.7	84.19	29.76	82.30	30.01	76.63	31.14	73.67	29.73	70.70	28.36	64.76	25.65
	3	2.2	88.24	29.80	82.30	29.49	76.63	27.06	73.67	25.86	70.70	24.67	64.76	22.38
	5	4.1	88.24	29.07	82.30	26.92	76.63	24.81	73.67	23.75	70.70	22.73	64.76	20.76
	7	6	88.24	25.27	82.30	23.51	76.63	21.78	73.67	20.94	70.70	20.13	64.76	18.47
9	7.9	88.24	23.72	82.30	22.20	76.63	20.69	73.67	19.95	70.70	19.21	64.76	17.77	
11	9.8	88.24	22.34	82.30	21.01	76.63	19.71	73.67	19.04	70.70	18.40	64.76	17.14	
13	11.8	88.24	21.11	82.30	19.95	76.63	18.83	73.67	18.26	70.70	17.70	64.76	16.57	
15	13.7	88.24	20.23	82.30	19.21	76.63	18.19	73.67	17.70	70.70	17.21	64.76	16.19	
80%	-25	-25.4	67.28	29.38	67.01	30.18	68.00	29.37	65.30	28.01	62.87	26.68	57.48	24.08
	-19.8	-20	68.54	29.43	68.27	29.74	68.00	28.74	65.30	27.42	62.87	26.13	57.48	23.59
	-18.8	-19	69.08	29.47	68.81	29.74	68.00	28.46	65.30	27.14	62.87	25.85	57.48	23.35
	-16.7	-17	70.16	29.50	69.89	29.81	68.00	27.87	65.30	26.58	62.87	25.33	57.48	22.86
	-13.7	-15	71.24	29.57	70.97	29.85	68.00	27.31	65.30	26.06	62.87	24.84	57.48	22.45
	-11.8	-13	72.32	29.61	72.05	29.29	68.00	26.76	65.30	25.54	62.87	24.36	57.48	22.03
	-9.8	-11	73.40	29.64	73.13	28.70	68.00	26.27	65.30	25.05	62.87	23.91	57.48	21.61
	-9.5	-10	73.94	29.67	73.13	28.42	68.00	25.99	65.30	24.81	62.87	23.66	57.48	21.40
	-8.5	-9.1	74.48	29.71	73.13	28.18	68.00	25.78	65.30	24.60	62.87	23.45	57.48	21.23
	-7	-7.6	75.29	29.74	73.13	27.76	68.00	25.44	65.30	24.29	62.87	23.14	57.48	20.95
	-5	-5.6	78.52	29.15	73.13	26.86	68.00	24.64	65.30	23.52	62.87	22.48	57.48	20.36
	-3	-3.7	78.52	30.16	73.13	27.80	68.00	25.50	65.30	24.36	62.87	23.25	57.48	21.09
	0	-0.7	78.52	31.69	73.13	29.22	68.00	26.79	65.30	25.61	62.87	24.46	57.48	22.20
	3	2.2	78.52	27.52	73.13	25.40	68.00	23.35	65.30	22.34	62.87	21.37	57.48	19.42
	5	4.1	78.52	25.16	73.13	23.35	68.00	21.58	65.30	20.71	62.87	19.84	57.48	18.17
	7	6	78.52	22.06	73.13	20.61	68.00	19.15	65.30	18.42	62.87	17.72	57.48	16.33
9	7.9	78.52	20.92	73.13	19.63	68.00	18.35	65.30	17.72	62.87	17.06	57.48	15.84	
11	9.8	78.52	19.88	73.13	18.73	68.00	17.62	65.30	17.06	62.87	16.51	57.48	15.43	
13	11.8	78.52	18.97	73.13	17.96	68.00	16.99	65.30	16.51	62.87	16.02	57.48	15.05	
15	13.7	78.52	18.31	73.13	17.41	68.00	16.54	65.30	16.12	62.87	15.67	57.48	14.80	

Обозначения:

CR: Индекс установленной мощности;
 ТС: Полная производительность (кВт);
 PI: Потребляемая мощность (компрессор + двигатель вентилятора наружного блока) (кВт)

Примечание: 1. В серых ячейках указаны расчётные значения.

Продолжение таблицы на следующей странице...

MVS FDC II-S

Таблица 2-8.16: Таблица теплопроизводительности для блоков производительностью 30 л.с. (продолжение)

CR	Температура наружного воздуха (°C DB)		Температура в помещении °C DB											
			16.0		18.0		20.0		21.0		22.0		24.0	
	°C DB	°C WB	ТС	PI	ТС	PI	ТС	PI	ТС	PI	ТС	PI	ТС	PI
			кВт	кВт	кВт	кВт	кВт	кВт	кВт	кВт	кВт	кВт	кВт	кВт
70%	-25	-25.4	68.11	30.08	63.95	27.66	59.63	25.34	57.21	24.20	55.05	23.09	50.46	20.89
	-19.8	-20	68.00	29.45	63.95	27.10	59.63	24.84	57.21	23.72	55.05	22.63	50.46	20.48
	-18.8	-19	68.54	29.14	63.95	26.81	59.63	24.56	57.21	23.47	55.05	22.42	50.46	20.30
	-16.7	-17	68.54	28.54	63.95	26.29	59.63	24.10	57.21	23.01	55.05	21.96	50.46	19.92
	-13.7	-15	68.54	27.97	63.95	25.76	59.63	23.61	57.21	22.59	55.05	21.54	50.46	19.53
	-11.8	-13	68.54	27.41	63.95	25.27	59.63	23.19	57.21	22.13	55.05	21.15	50.46	19.18
	-9.8	-11	68.54	26.88	63.95	24.77	59.63	22.73	57.21	21.75	55.05	20.76	50.46	18.83
	-9.5	-10	68.54	26.64	63.95	24.56	59.63	22.52	57.21	21.54	55.05	20.55	50.46	18.69
	-8.5	-9.1	68.54	26.39	63.95	24.35	59.63	22.34	57.21	21.36	55.05	20.41	50.46	18.51
	-7	-7.6	68.54	26.04	63.95	24.00	59.63	22.03	57.21	21.08	55.05	20.13	50.46	18.26
	-5	-5.6	68.54	25.23	63.95	23.29	59.63	21.43	57.21	20.51	55.05	19.60	50.46	17.84
	-3	-3.7	68.54	26.11	63.95	24.10	59.63	22.17	57.21	21.22	55.05	20.30	50.46	18.47
	0	-0.7	68.54	27.45	63.95	25.37	59.63	23.33	57.21	22.34	55.05	21.36	50.46	19.46
	3	2.2	68.54	23.89	63.95	22.13	59.63	20.41	57.21	19.56	55.05	18.72	50.46	17.10
	5	4.1	68.54	22.06	63.95	20.55	59.63	19.04	57.21	18.30	55.05	17.56	50.46	16.12
7	6	68.54	19.56	63.95	18.30	59.63	17.07	57.21	16.43	55.05	15.83	50.46	14.64	
9	7.9	68.54	18.72	63.95	17.59	59.63	16.50	57.21	19.49	55.05	15.41	50.46	14.36	
11	9.8	68.54	17.98	63.95	17.00	59.63	16.01	57.21	15.55	55.05	15.06	50.46	14.11	
13	11.8	68.54	17.31	63.95	16.47	59.63	15.59	57.21	15.17	55.05	14.74	50.46	13.90	
15	13.7	68.54	16.86	63.95	16.08	59.63	15.34	57.21	14.96	55.05	14.57	50.46	13.83	
60%	-25	-25.4	58.83	25.05	55.05	23.10	51.00	21.21	49.11	20.28	46.95	19.39	43.17	17.62
	-19.8	-20	58.83	24.53	55.05	22.63	51.00	20.80	49.11	19.88	46.95	19.00	43.17	17.28
	-18.8	-19	58.83	24.28	55.05	22.42	51.00	20.59	49.11	19.71	46.95	18.83	43.17	17.14
	-16.7	-17	58.83	23.79	55.05	21.96	51.00	20.20	49.11	19.32	46.95	18.47	43.17	16.82
	-13.7	-15	58.83	23.33	55.05	21.54	51.00	19.81	49.11	18.97	46.95	18.16	43.17	16.50
	-11.8	-13	58.83	22.87	55.05	21.15	51.00	19.46	49.11	18.61	46.95	17.81	43.17	16.22
	-9.8	-11	58.83	22.45	55.05	20.76	51.00	19.11	49.11	18.30	46.95	17.49	43.17	15.94
	-9.5	-10	58.83	22.24	55.05	20.55	51.00	18.93	49.11	18.12	46.95	17.35	43.17	15.80
	-8.5	-9.1	58.83	22.09	55.05	20.41	51.00	18.79	49.11	17.98	46.95	17.21	43.17	15.69
	-7	-7.6	58.83	21.75	55.05	20.13	51.00	18.54	49.11	17.77	46.95	17.00	43.17	15.48
	-5	-5.6	58.83	21.15	55.05	19.60	51.00	18.09	49.11	17.35	46.95	16.61	43.17	15.17
	-3	-3.7	58.83	21.92	55.05	20.30	51.00	18.72	49.11	17.98	46.95	17.21	43.17	15.73
	0	-0.7	58.83	23.05	55.05	21.36	51.00	19.74	49.11	18.93	46.95	18.12	43.17	16.57
	3	2.2	58.83	20.16	55.05	18.72	51.00	17.31	49.11	16.64	46.95	15.94	43.17	14.60
	5	4.1	58.83	18.83	55.05	17.56	51.00	16.33	49.11	15.73	46.95	15.13	43.17	13.93
7	6	58.83	16.89	55.05	15.83	51.00	14.81	49.11	14.29	46.95	13.79	43.17	12.81	
9	7.9	58.83	16.36	55.05	15.41	51.00	14.50	49.11	14.04	46.95	13.62	43.17	12.70	
11	9.8	58.83	15.87	55.05	15.06	51.00	14.25	49.11	13.83	46.95	13.44	43.17	12.63	
13	11.8	58.83	15.48	55.05	14.74	51.00	14.04	49.11	13.65	46.95	13.30	43.17	12.60	
15	13.7	58.83	15.24	55.05	14.57	51.00	13.93	49.11	13.62	46.95	13.30	43.17	12.63	
50%	-25	-25.4	49.11	20.24	45.87	18.76	42.63	17.30	40.75	18.11	39.13	15.89	35.89	14.52
	-19.8	-20	49.11	19.88	45.87	18.44	42.63	17.00	40.75	16.33	39.13	15.62	35.89	14.29
	-18.8	-19	49.11	19.71	45.87	18.26	42.63	16.86	40.75	19.67	39.13	15.48	35.89	14.15
	-16.7	-17	49.11	19.32	45.87	17.91	42.63	16.54	40.75	15.87	39.13	15.20	35.89	13.90
	-13.7	-15	49.11	18.97	45.87	17.59	42.63	16.26	40.75	15.59	39.13	14.96	35.89	13.65
	-11.8	-13	49.11	18.61	45.87	17.28	42.63	15.98	40.75	15.31	39.13	14.67	35.89	13.44
	-9.8	-11	49.11	18.30	45.87	17.00	42.63	15.69	40.75	15.06	39.13	14.43	35.89	13.20
	-9.5	-10	49.11	18.12	45.87	16.82	42.63	15.55	40.75	14.92	39.13	14.32	35.89	13.09
	-8.5	-9.1	49.11	17.98	45.87	16.71	42.63	15.45	40.75	14.81	39.13	14.22	35.89	13.02
	-7	-7.6	49.11	17.77	45.87	16.50	42.63	15.24	40.75	14.64	39.13	14.04	35.89	12.84
	-5	-5.6	49.11	17.35	45.87	16.12	42.63	14.92	40.75	14.36	39.13	13.76	35.89	12.63
	-3	-3.7	49.11	17.98	45.87	16.71	42.63	15.48	40.75	14.88	39.13	14.29	35.89	13.09
	0	-0.7	49.11	18.93	45.87	17.59	42.63	16.33	40.75	15.69	39.13	15.06	35.89	13.83
	3	2.2	49.11	16.64	45.87	15.52	42.63	14.39	40.75	13.86	39.13	13.30	35.89	12.25
	5	4.1	49.11	15.73	45.87	14.71	42.63	13.76	40.75	13.27	39.13	12.77	35.89	11.82
7	6	49.11	14.29	45.87	13.48	42.63	12.63	40.75	12.25	39.13	11.82	35.89	11.01	
9	7.9	49.11	14.04	45.87	13.30	42.63	12.56	40.75	12.21	39.13	11.82	35.89	11.12	
11	9.8	49.11	13.83	45.87	13.16	42.63	12.49	40.75	12.18	39.13	11.86	35.89	11.19	
13	11.8	49.11	13.65	45.87	13.05	42.63	12.49	40.75	12.18	39.13	11.86	35.89	11.33	
15	13.7	49.11	13.62	45.87	13.05	42.63	12.53	40.75	12.28	39.13	12.03	35.89	11.51	

Обозначения:

CR: Индекс установленной мощности;
 ТС: Полная производительность (кВт);
 PI: Потребляемая мощность (компрессор + двигатель вентилятора наружного блока) (кВт)

Примечание: 1. В серых ячейках указаны расчётные значения.

Таблица 2-8.17: Таблица теплопроизводительности для блоков производительностью 32 л.с.

CR	Температура наружного воздуха (°C DB)		Температура в помещении °C DB											
			16.0		18.0		20.0		21.0		22.0		24.0	
	°C DB	°C WB	TC	PI	TC	PI	TC	PI	TC	PI	TC	PI	TC	PI
			кВт	кВт	кВт	кВт	кВт	кВт	кВт	кВт	кВт	кВт	кВт	кВт
130%	-25	-25.4	72.54	28.87	72.26	29.15	71.97	29.45	71.74	29.64	71.69	29.82	71.29	30.21
	-19.8	-20	73.80	28.92	73.51	29.22	73.23	29.51	72.94	29.69	72.94	29.88	72.66	30.28
	-18.8	-19	74.37	28.96	74.08	29.22	73.80	29.55	73.80	29.73	73.51	29.91	73.23	30.28
	-16.7	-17	75.51	29.00	75.22	29.29	74.94	29.58	74.94	29.77	74.65	29.95	74.37	30.35
	-13.7	-15	76.65	29.03	76.36	29.33	76.08	29.66	76.08	29.84	75.79	30.02	75.51	30.39
	-11.8	-13	77.79	29.11	77.50	29.40	77.22	29.69	77.22	29.88	76.93	30.06	76.93	30.46
	-9.8	-11	78.92	29.14	78.64	29.44	78.35	29.77	78.35	29.91	78.35	30.10	78.07	30.50
	-9.5	-10	79.49	29.18	79.21	29.44	79.21	29.77	78.92	29.95	78.92	30.13	78.64	30.54
	-8.5	-9.1	80.06	29.18	79.78	29.47	79.49	29.80	79.49	29.99	79.49	30.17	79.21	30.57
	-7	-7.6	80.92	29.22	80.63	29.51	80.63	29.84	80.35	30.02	80.35	30.21	80.06	30.61
	-5	-5.6	87.19	31.34	86.90	31.67	86.62	32.00	86.62	32.22	86.33	32.41	86.05	32.81
	-3	-3.7	88.33	32.99	88.04	33.36	87.76	33.73	87.76	33.91	87.47	34.13	87.19	34.57
	0	-0.7	90.04	35.63	89.75	36.04	89.47	36.44	89.47	36.62	89.18	36.84	89.18	37.32
	3	2.2	98.30	34.97	98.30	35.34	98.01	35.74	97.73	35.93	97.73	36.15	97.44	35.74
	5	4.1	123.66	43.26	123.37	43.00	116.82	39.33	112.26	37.54	107.70	35.78	98.87	32.33
7	6	134.77	39.52	125.65	36.51	116.82	33.58	112.26	32.15	107.70	30.72	98.87	27.97	
9	7.9	134.77	36.07	125.65	33.51	116.82	30.98	112.26	29.77	107.70	28.56	98.87	26.14	
11	9.8	134.77	33.07	125.65	30.83	116.82	28.70	112.26	27.68	107.70	26.61	98.87	24.52	
13	11.8	134.77	30.46	125.65	28.56	116.82	26.72	112.26	25.81	107.70	24.89	98.87	23.09	
15	13.7	134.77	28.48	125.65	26.83	116.82	25.22	112.26	24.41	107.70	23.61	98.87	22.03	
120%	-25	-25.4	72.76	30.16	72.48	30.46	72.19	30.80	72.19	30.97	71.88	31.18	71.67	31.59
	-19.8	-20	73.71	30.20	73.43	30.50	73.14	30.84	73.14	31.03	72.86	31.22	72.57	31.64
	-18.8	-19	74.29	30.24	74.00	30.54	73.71	30.88	73.71	31.03	73.43	31.26	73.14	31.64
	-16.7	-17	75.43	30.28	75.14	30.58	74.86	30.92	74.86	31.11	74.57	31.30	74.57	31.71
	-13.7	-15	76.57	30.31	76.29	30.65	76.00	30.99	76.00	31.15	76.00	31.37	75.71	31.75
	-11.8	-13	77.71	30.39	77.43	30.69	77.14	31.03	77.14	31.22	77.14	31.41	76.86	31.83
	-9.8	-11	78.86	30.43	78.57	30.73	78.29	31.07	78.29	31.26	78.29	31.45	78.00	31.86
	-9.5	-10	79.43	30.46	79.14	30.77	79.14	31.11	78.86	31.30	78.86	31.49	78.57	31.90
	-8.5	-9.1	80.00	30.46	79.71	30.80	79.71	31.15	79.43	31.33	79.43	31.52	79.14	31.90
	-7	-7.6	80.86	30.50	80.57	30.84	80.57	31.18	80.29	31.37	80.29	31.56	80.00	31.94
	-5	-5.6	87.14	32.73	86.86	33.08	86.57	33.45	86.57	33.64	86.57	33.83	86.29	34.25
	-3	-3.7	88.29	34.48	88.00	34.85	87.71	35.23	87.71	35.42	87.43	35.65	87.43	36.07
	0	-0.7	90.00	37.24	89.71	37.62	89.43	38.03	89.43	38.26	89.43	38.49	89.14	38.71
	3	2.2	98.29	36.56	98.29	36.90	98.00	37.31	97.71	37.50	97.71	37.24	91.43	33.53
	5	4.1	123.71	43.82	116.29	40.30	108.00	36.94	103.71	35.27	99.71	33.64	91.43	30.46
7	6	124.57	37.24	116.29	34.44	108.00	31.71	103.71	30.39	99.71	29.10	91.43	26.53	
9	7.9	124.57	34.17	116.29	31.79	108.00	29.48	103.71	28.31	99.71	27.17	91.43	24.94	
11	9.8	124.57	31.52	116.29	29.48	108.00	27.47	103.71	26.49	99.71	25.51	91.43	23.54	
13	11.8	124.57	29.18	116.29	27.44	108.00	25.70	103.71	24.83	99.71	23.99	91.43	22.29	
15	13.7	124.57	27.44	116.29	25.92	108.00	24.37	103.71	23.61	99.71	22.90	91.43	21.42	
110%	-25	-25.4	72.37	30.95	72.04	31.28	71.69	31.62	71.80	31.80	71.54	32.01	71.51	32.41
	-19.8	-20	73.43	31.00	73.14	31.34	72.86	31.69	72.86	31.84	72.57	32.07	72.57	32.45
	-18.8	-19	74.00	31.04	73.71	31.34	73.43	31.69	73.43	31.88	73.14	32.07	73.14	32.49
	-16.7	-17	75.14	31.07	74.86	31.42	74.57	31.76	74.57	31.96	74.57	32.15	74.29	32.53
	-13.7	-15	76.29	31.15	76.00	31.46	75.71	31.80	75.71	31.99	75.71	32.19	75.43	32.61
	-11.8	-13	77.43	31.19	77.14	31.53	77.14	31.88	76.86	32.07	76.86	32.26	76.57	32.65
	-9.8	-11	78.57	31.27	78.29	31.57	78.29	31.92	78.00	32.11	78.00	32.30	77.71	32.72
	-9.5	-10	79.14	31.27	79.14	31.61	78.86	31.96	78.57	32.15	78.57	32.34	78.29	32.72
	-8.5	-9.1	79.71	31.30	79.43	31.61	79.43	31.99	79.14	32.15	79.14	32.34	78.86	32.76
	-7	-7.6	80.57	31.34	80.29	31.65	80.29	32.03	80.00	32.19	80.00	32.38	79.71	32.80
	-5	-5.6	86.86	33.64	86.57	33.99	86.29	34.33	86.29	34.53	86.29	34.72	83.71	32.53
	-3	-3.7	88.00	35.41	87.71	35.79	87.43	36.18	87.43	36.37	87.43	36.56	83.71	33.64
	0	-0.7	89.71	38.25	89.43	38.63	89.43	39.05	89.14	39.28	89.14	39.24	83.71	35.33
	3	2.2	98.00	37.52	98.00	37.90	97.71	37.40	95.14	35.68	91.43	33.99	83.71	30.65
	5	4.1	114.29	40.01	106.57	36.87	99.14	33.84	95.14	36.18	91.43	30.88	83.71	28.04
7	6	114.29	34.22	106.57	31.73	99.14	29.27	95.14	28.08	91.43	26.89	83.71	24.59	
9	7.9	114.29	31.65	106.57	29.46	99.14	27.35	95.14	26.32	91.43	25.28	83.71	23.29	
11	9.8	114.29	29.39	106.57	27.51	99.14	25.66	95.14	24.78	91.43	23.86	83.71	22.10	
13	11.8	114.29	27.35	106.57	25.74	99.14	24.17	95.14	23.40	91.43	22.60	83.71	21.06	
15	13.7	114.29	25.89	106.57	24.48	99.14	23.06	95.14	22.37	91.43	21.71	83.71	20.33	

Dantex MVS FDC II-S серия. Техническая инструкция

Обозначения:
 CR: Индекс установленной мощности;
 TC: Полная производительность (кВт);
 PI: Потребляемая мощность (компрессор + двигатель вентилятора наружного блока) (кВт)

Примечание: 1. В серых ячейках указаны расчётные значения.

Продолжение таблицы на следующей странице...

MVS FDC II-S

Таблица 2-8.17: Таблица теплопроизводительности для блоков производительностью 32 л.с. (продолжение)

CR	Температура наружного воздуха (°C DB)		Температура в помещении °C DB											
			16.0		18.0		20.0		21.0		22.0		24.0	
	°C DB	°C WB	ТС	PI	ТС	PI	ТС	PI	ТС	PI	ТС	PI	ТС	PI
100%	-25	-25.4	73.14	31.46	72.86	31.76	72.57	32.11	72.57	32.30	72.57	32.49	72.29	32.91
	-19.8	-20	73.71	31.46	73.43	31.80	73.14	32.15	73.14	32.34	73.14	32.53	72.86	32.91
	-18.8	-19	74.86	31.53	74.57	31.88	74.29	32.22	74.29	32.38	74.29	32.57	74.00	32.95
	-16.7	-17	76.00	31.57	75.71	31.92	75.71	32.26	75.43	32.45	75.43	32.65	75.14	32.26
	-13.7	-15	77.14	31.65	76.86	31.96	76.86	32.34	76.57	32.49	76.57	32.68	76.29	31.61
	-11.8	-13	78.29	31.69	78.00	32.03	78.00	32.38	77.71	32.57	77.71	32.72	76.29	31.00
	-9.8	-11	78.86	31.73	78.86	32.07	78.57	32.42	78.57	32.57	78.29	32.76	76.29	30.69
	-9.5	-10	79.43	31.76	79.14	32.07	79.14	32.42	78.86	32.61	78.86	32.80	76.29	30.42
	-8.5	-9.1	80.29	31.80	80.29	32.11	80.00	32.45	79.71	32.65	79.71	32.84	76.29	30.00
	-7	-7.6	86.57	31.84	86.29	32.12	86.29	32.47	86.00	33.84	83.14	32.19	76.29	29.04
	-5	-5.6	87.71	31.88	87.43	32.14	87.43	32.49	86.57	34.99	83.14	33.30	76.29	30.04
	-3	-3.7	89.43	31.92	89.14	32.16	89.14	31.42	86.57	32.91	83.14	34.99	76.29	31.57
	0	-0.7	91.71	31.96	96.86	32.18	90.00	30.54	86.57	34.60	83.14	32.99	76.29	29.65
	3	2.2	97.71	33.96	96.86	31.38	90.00	29.67	86.57	31.84	83.14	30.38	76.29	27.47
	5	4.1	103.71	32.20	96.86	29.85	90.00	28.27	86.57	29.08	83.14	27.77	76.29	25.28
	7	6	103.71	30.43	96.86	28.31	90.00	26.47	86.57	25.43	83.14	24.36	76.29	22.33
	9	7.9	103.71	28.70	96.86	26.82	90.00	24.94	86.57	24.01	83.14	23.09	76.29	21.29
11	9.8	103.71	26.85	96.86	25.17	90.00	23.55	86.57	22.75	83.14	21.94	76.29	20.37	
13	11.8	103.71	25.17	96.86	23.75	90.00	22.33	86.57	21.64	83.14	20.95	76.29	19.56	
15	13.7	103.71	23.94	96.86	22.71	90.00	21.44	86.57	20.83	83.14	20.22	76.29	18.99	
90%	-25	-25.4	71.52	31.90	71.14	32.20	70.91	32.55	70.86	33.21	71.98	33.80	68.57	30.56
	-19.8	-20	72.86	31.96	72.57	32.26	72.29	32.61	72.29	32.80	72.29	32.99	68.57	29.92
	-18.8	-19	73.43	31.99	73.14	32.30	72.86	32.65	72.86	32.84	72.86	32.88	68.57	29.62
	-16.7	-17	74.57	32.03	74.29	32.34	74.29	32.68	74.00	32.88	74.00	32.22	68.57	29.00
	-13.7	-15	75.71	32.07	75.43	32.42	75.43	32.76	75.14	32.91	74.86	31.57	68.57	28.43
	-11.8	-13	76.86	32.15	76.57	32.45	76.57	32.80	76.29	32.49	74.86	30.92	68.57	27.89
	-9.8	-11	78.00	32.19	78.00	32.53	77.71	32.84	77.71	31.84	74.86	30.34	68.57	27.35
	-9.5	-10	78.57	32.22	78.57	32.53	78.29	32.88	78.00	31.53	74.86	30.04	68.57	27.08
	-8.5	-9.1	79.14	32.26	78.86	32.57	78.86	32.80	78.00	31.27	74.86	29.77	68.57	26.85
	-7	-7.6	80.00	32.30	80.00	32.61	79.71	32.34	78.00	30.84	74.86	29.35	68.57	26.47
	-5	-5.6	86.29	32.36	86.00	32.64	81.14	31.23	78.00	29.81	74.86	28.43	68.57	25.70
	-3	-3.7	87.43	32.40	87.14	32.68	81.14	32.30	78.00	30.84	74.86	29.42	68.57	26.59
	0	-0.7	89.14	32.45	87.14	32.71	81.14	33.95	78.00	32.42	74.86	30.92	68.57	27.97
	3	2.2	93.43	32.49	87.14	32.15	81.14	29.50	78.00	28.20	74.86	26.89	68.57	24.40
	5	4.1	93.43	31.69	87.14	29.35	81.14	27.05	78.00	25.89	74.86	24.78	68.57	22.63
	7	6	93.43	27.54	87.14	25.63	81.14	23.75	78.00	22.83	74.86	21.94	68.57	20.14
	9	7.9	93.43	25.86	87.14	24.21	81.14	22.56	78.00	21.75	74.86	20.95	68.57	19.37
11	9.8	93.43	24.36	87.14	22.90	81.14	21.48	78.00	20.75	74.86	20.06	68.57	18.68	
13	11.8	93.43	23.02	87.14	21.75	81.14	20.52	78.00	19.91	74.86	19.30	68.57	18.07	
15	13.7	93.43	22.06	87.14	20.95	81.14	19.83	78.00	19.30	74.86	18.76	68.57	17.65	
80%	-25	-25.4	71.24	32.03	70.95	32.90	72.00	32.02	69.14	30.54	66.57	29.09	60.86	26.25
	-19.8	-20	72.57	32.09	72.29	32.43	72.00	31.33	69.14	29.89	66.57	28.49	60.86	25.72
	-18.8	-19	73.14	32.12	72.86	32.43	72.00	31.03	69.14	29.59	66.57	28.18	60.86	25.46
	-16.7	-17	74.29	32.16	74.00	32.50	72.00	30.38	69.14	28.98	66.57	27.62	60.86	24.93
	-13.7	-15	75.43	32.24	75.14	32.54	72.00	29.78	69.14	28.41	66.57	27.09	60.86	24.47
	-11.8	-13	76.57	32.28	76.29	31.93	72.00	29.17	69.14	27.84	66.57	26.56	60.86	24.02
	-9.8	-11	77.71	32.31	77.43	31.29	72.00	28.64	69.14	27.31	66.57	26.06	60.86	23.56
	-9.5	-10	78.29	32.35	77.43	30.99	72.00	28.34	69.14	27.05	66.57	25.80	60.86	23.34
	-8.5	-9.1	78.86	32.39	77.43	30.72	72.00	28.11	69.14	26.82	66.57	25.57	60.86	23.15
	-7	-7.6	79.71	32.43	77.43	30.27	72.00	27.73	69.14	26.48	66.57	25.23	60.86	22.84
	-5	-5.6	83.14	31.78	77.43	29.28	72.00	26.86	69.14	25.65	66.57	24.51	60.86	22.20
	-3	-3.7	83.14	32.88	77.43	30.31	72.00	27.81	69.14	26.56	66.57	25.34	60.86	22.99
	0	-0.7	83.14	34.55	77.43	31.86	72.00	29.21	69.14	27.92	66.57	26.67	60.86	24.21
	3	2.2	83.14	30.00	77.43	27.69	72.00	25.46	69.14	24.36	66.57	23.30	60.86	21.18
	5	4.1	83.14	27.43	77.43	25.46	72.00	23.52	69.14	22.58	66.57	21.63	60.86	19.81
	7	6	83.14	24.06	77.43	22.46	72.00	20.87	69.14	20.08	66.57	19.32	60.86	17.80
	9	7.9	83.14	22.80	77.43	21.40	72.00	20.00	69.14	19.32	66.57	18.60	60.86	17.27
11	9.8	83.14	21.67	77.43	20.42	72.00	19.21	69.14	18.60	66.57	17.99	60.86	16.82	
13	11.8	83.14	20.68	77.43	19.58	72.00	18.52	69.14	17.99	66.57	17.46	60.86	16.40	
15	13.7	83.14	19.96	77.43	18.98	72.00	18.03	69.14	17.58	66.57	17.08	60.86	16.14	

Обозначения:

- CR: Индекс установленной мощности;
- ТС: Полная производительность (кВт);
- PI: Потребляемая мощность (компрессор + двигатель вентилятора наружного блока) (кВт)

Примечание: 1. В серых ячейках указаны расчётные значения.

Продолжение таблицы на следующей странице...

Часть 2 Технические характеристики наружных блоков

Таблица 2-8.17: Таблица теплопроизводительности для блоков производительностью 32 л.с. (продолжение)

CR	Температура наружного воздуха (°C DB)		Температура в помещении °C DB											
			16.0		18.0		20.0		21.0		22.0		24.0	
			ТС	PI	ТС	PI	ТС	PI	ТС	PI	ТС	PI	ТС	PI
	°C DB	°C WB	кВт	кВт	кВт	кВт	кВт	кВт	кВт	кВт	кВт	кВт	кВт	кВт
70%	-25	-25.4	73.14	31.46	72.86	31.76	72.57	32.11	72.57	32.30	72.57	32.49	72.29	32.91
	-19.8	-20	73.71	31.46	73.43	31.80	73.14	32.15	73.14	32.34	73.14	32.53	72.86	32.91
	-18.8	-19	74.86	31.53	74.57	31.88	74.29	32.22	74.29	32.38	74.29	32.57	74.00	32.95
	-16.7	-17	76.00	31.57	75.71	31.92	75.71	32.26	75.43	32.45	75.43	32.65	75.14	32.26
	-13.7	-15	77.14	31.65	76.86	31.96	76.86	32.34	76.57	32.49	76.57	32.68	76.29	31.61
	-11.8	-13	78.29	31.69	78.00	32.03	78.00	32.38	77.71	32.57	77.71	32.72	76.29	31.00
	-9.8	-11	78.86	31.73	78.86	32.07	78.57	32.42	78.57	32.57	78.29	32.76	76.29	30.69
	-9.5	-10	79.43	31.76	79.14	32.07	79.14	32.42	78.86	32.61	78.86	32.80	76.29	30.42
	-8.5	-9.1	80.29	31.80	80.29	32.11	80.00	32.45	79.71	32.65	79.71	32.84	76.29	30.00
	-7	-7.6	86.57	31.84	86.29	32.12	86.29	32.47	86.00	33.84	83.14	32.19	76.29	29.04
	-5	-5.6	87.71	31.88	87.43	32.14	87.43	32.49	86.57	34.99	83.14	33.30	76.29	30.04
	-3	-3.7	89.43	31.92	89.14	32.16	89.14	31.42	86.57	32.91	83.14	34.99	76.29	31.57
	0	-0.7	91.71	31.96	96.86	32.18	90.00	30.54	86.57	34.60	83.14	32.99	76.29	29.65
	3	2.2	97.71	33.96	96.86	31.38	90.00	29.67	86.57	31.84	83.14	30.38	76.29	27.47
	5	4.1	103.71	32.20	96.86	29.85	90.00	28.27	86.57	29.08	83.14	27.77	76.29	25.28
	7	6	103.71	30.43	96.86	28.31	90.00	26.47	86.57	25.43	83.14	24.36	76.29	22.33
9	7.9	103.71	28.70	96.86	26.82	90.00	24.94	86.57	24.01	83.14	23.09	76.29	21.29	
11	9.8	103.71	26.85	96.86	25.17	90.00	23.55	86.57	22.75	83.14	21.94	76.29	20.37	
13	11.8	103.71	25.17	96.86	23.75	90.00	22.33	86.57	21.64	83.14	20.95	76.29	19.56	
15	13.7	103.71	23.94	96.86	22.71	90.00	21.44	189.43	20.83	83.14	20.22	76.29	18.99	
60%	-25	-25.4	71.52	31.90	71.14	32.20	70.91	32.55	70.86	33.21	71.98	33.80	68.57	30.56
	-19.8	-20	72.86	31.96	72.57	32.26	72.29	32.61	72.29	32.80	72.29	32.99	68.57	29.92
	-18.8	-19	73.43	31.99	73.14	32.30	72.86	32.65	72.86	32.84	72.86	32.88	68.57	29.62
	-16.7	-17	74.57	32.03	74.29	32.34	74.29	32.68	74.00	32.88	74.00	32.22	68.57	29.00
	-13.7	-15	75.71	32.07	75.43	32.42	75.43	32.76	75.14	32.91	74.86	31.57	68.57	28.43
	-11.8	-13	76.86	32.15	76.57	32.45	76.57	32.80	76.29	32.49	74.86	30.92	68.57	27.89
	-9.8	-11	78.00	32.19	78.00	32.53	77.71	32.84	77.71	31.84	74.86	30.34	68.57	27.35
	-9.5	-10	78.57	32.22	78.57	32.53	78.29	32.88	78.00	31.53	74.86	30.04	68.57	27.08
	-8.5	-9.1	79.14	32.26	78.86	32.57	78.86	32.80	78.00	31.27	74.86	29.77	68.57	26.85
	-7	-7.6	80.00	32.30	80.00	32.61	79.71	32.34	78.00	30.84	74.86	29.35	68.57	26.47
	-5	-5.6	86.29	32.36	86.00	32.64	81.14	31.23	78.00	29.81	74.86	28.43	68.57	25.70
	-3	-3.7	87.43	32.40	87.14	32.68	81.14	32.30	78.00	30.84	74.86	29.42	68.57	26.59
	0	-0.7	89.14	32.45	87.14	32.71	81.14	33.95	78.00	32.42	74.86	30.92	68.57	27.97
	3	2.2	93.43	32.49	87.14	32.15	81.14	29.50	78.00	28.20	74.86	26.89	68.57	24.40
	5	4.1	93.43	31.69	87.14	29.35	81.14	27.05	78.00	25.89	74.86	24.78	68.57	22.63
	7	6	93.43	27.54	87.14	25.63	81.14	23.75	78.00	22.83	74.86	21.94	68.57	20.14
9	7.9	93.43	25.86	87.14	24.21	81.14	22.56	78.00	21.75	74.86	20.95	68.57	19.37	
11	9.8	93.43	24.36	87.14	22.90	81.14	21.48	78.00	20.75	74.86	20.06	68.57	18.68	
13	11.8	93.43	23.02	87.14	21.75	81.14	20.52	78.00	19.91	74.86	19.30	68.57	18.07	
15	13.7	93.43	22.06	87.14	20.95	81.14	19.83	78.00	19.30	74.86	18.76	68.57	17.65	
50%	-25	-25.4	71.24	32.03	70.95	32.90	72.00	32.02	69.14	30.54	66.57	29.09	60.86	26.25
	-19.8	-20	72.57	32.09	72.29	32.43	72.00	31.33	69.14	29.89	66.57	28.49	60.86	25.72
	-18.8	-19	73.14	32.12	72.86	32.43	72.00	31.03	69.14	29.59	66.57	28.18	60.86	25.46
	-16.7	-17	74.29	32.16	74.00	32.50	72.00	30.38	69.14	28.98	66.57	27.62	60.86	24.93
	-13.7	-15	75.43	32.24	75.14	32.54	72.00	29.78	69.14	28.41	66.57	27.09	60.86	24.47
	-11.8	-13	76.57	32.28	76.29	31.93	72.00	29.17	69.14	27.84	66.57	26.56	60.86	24.02
	-9.8	-11	77.71	32.31	77.43	31.29	72.00	28.64	69.14	27.31	66.57	26.06	60.86	23.56
	-9.5	-10	78.29	32.35	77.43	30.99	72.00	28.34	69.14	27.05	66.57	25.80	60.86	23.34
	-8.5	-9.1	78.86	32.39	77.43	30.72	72.00	28.11	69.14	26.82	66.57	25.57	60.86	23.15
	-7	-7.6	79.71	32.43	77.43	30.27	72.00	27.73	69.14	26.48	66.57	25.23	60.86	22.84
	-5	-5.6	83.14	31.78	77.43	29.28	72.00	26.86	69.14	25.65	66.57	24.51	60.86	22.20
	-3	-3.7	83.14	32.88	77.43	30.31	72.00	27.81	69.14	26.56	66.57	25.34	60.86	22.99
	0	-0.7	83.14	34.55	77.43	31.86	72.00	29.21	69.14	27.92	66.57	26.67	60.86	24.21
	3	2.2	83.14	30.00	77.43	27.69	72.00	25.46	69.14	24.36	66.57	23.30	60.86	21.18
	5	4.1	83.14	27.43	77.43	25.46	72.00	23.52	69.14	22.58	66.57	21.63	60.86	19.81
	7	6	83.14	24.06	77.43	22.46	72.00	20.87	69.14	20.08	66.57	19.32	60.86	17.80
9	7.9	83.14	22.80	77.43	21.40	72.00	20.00	69.14	19.32	66.57	18.60	60.86	17.27	
11	9.8	83.14	21.67	77.43	20.42	72.00	19.21	69.14	18.60	66.57	17.99	60.86	16.82	
13	11.8	83.14	20.68	77.43	19.58	72.00	18.52	69.14	17.99	66.57	17.46	60.86	16.40	
15	13.7	83.14	19.96	77.43	18.98	72.00	18.03	69.14	17.58	66.57	17.08	60.86	16.14	

Обозначения:

CR: Индекс установленной мощности;

ТС: Полная производительность (кВт);

PI: Потребляемая мощность (компрессор + двигатель вентилятора наружного блока) (кВт)

Примечание: 1. В серых ячейках указаны расчётные значения.

8.3 Поправочный коэффициент производительности модели на основании длины трубопровода и перепада высот

Рисунок 2-8.1: Скорость изменения холодопроизводительности

Рисунок 2-8.2: Скорость изменения теплопроизводительности

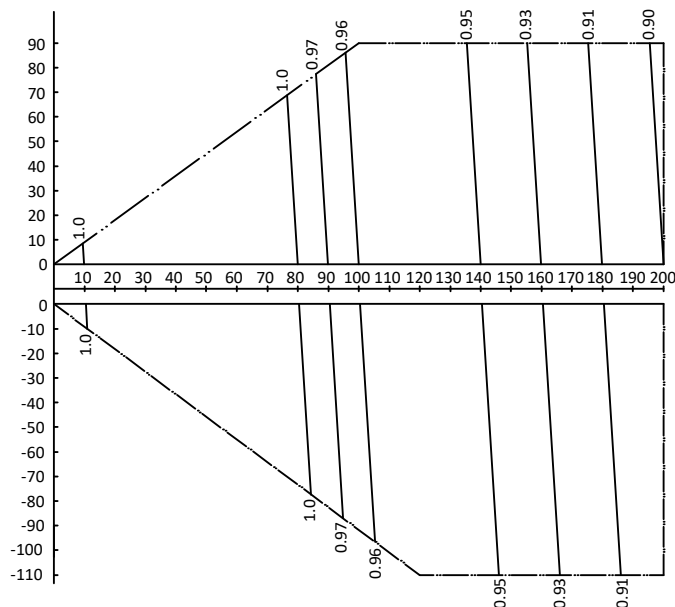
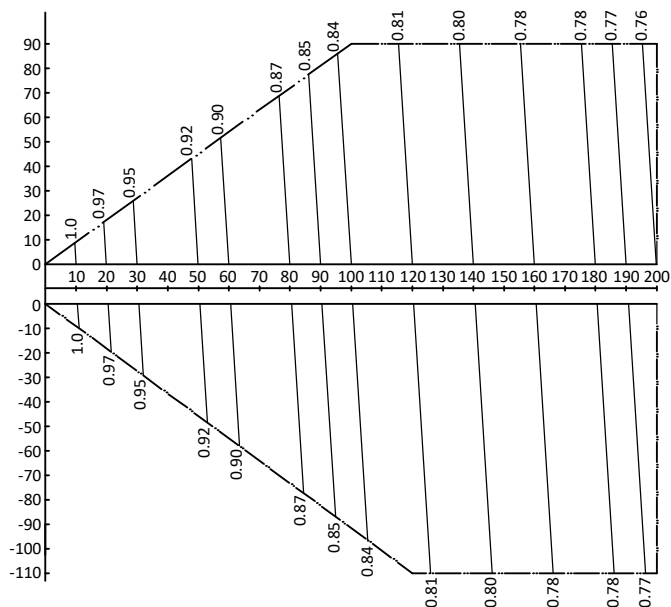

Примечание:

1. Горизонтальная ось обозначает эквивалентную длину трубопровода от самого удалённого внутреннего блока до первого разветвителя наружного блока; вертикальная ось обозначает максимальный перепад высот между внутренним и наружным блоками: положительные значения указывают, что наружный блок находится над внутренним блоком, а отрицательные значения указывают, что наружный блок находится под внутренним блоком.
2. Скорость изменения производительности указана только для стандартных внутренних блоков, работающих в стандартных условиях на максимальной нагрузке (при условии, что термостат установлен на максимальное значение). При частичной нагрузке скорость изменения производительности будет слегка отличаться от указанных выше значений.
3. Производительность системы - это либо полная производительность внутренних блоков, полученная из Таблиц производительности внутренних блоков, либо скорректированная производительность наружных блоков в соответствии с приведенными ниже расчетами, в зависимости от того, какое из значений будет меньше.

Скорректированная производительность наружных блоков	=	Производительность наружных блоков на основании комбинационного соотношения из Таблиц производительности наружных блоков	x	Поправочный коэффициент производительности
--	---	--	---	--

8.4 Поправочный коэффициент производительности модели на основании обмерзания

Таблицы теплопроизводительности не учитывают снижение производительности в результате обмерзания или оттайки. Теплопроизводительность снижается при скапливании инея на внешней стороне теплообменника наружного блока. Также на снижение теплопроизводительности оказывает воздействие ряд факторов, таких как температура наружного воздуха, относительная влажность воздуха и обмерзание.

Значение скорректированной теплопроизводительности на основании поправочного коэффициента можно вычислить, используя поправочный коэффициент производительности на основании обмерзания, указанный в Таблице 2-8.17:

$$\text{Скорректированная теплопроизводительность} = \text{Значение на основании Таблиц теплопроизводительности наружных блоков} \times \text{Поправочный коэффициент производительности модели на основании обмерзания}$$

Таблица 2-8.27: Поправочный коэффициент производительности модели на основании обмерзания

Температура на входе в теплообменник (°C при относительной влажности воздуха 85%)	-7	-5	-2	0	2	5	7
Поправочный коэффициент производительности модели на основании обмерзания	0,94	0,93	0,89	0,84	0,83	0,91	1,00

Скорректированная теплопроизводительность представляет собой значения теплопроизводительности в течение цикла обогрева/оттайки, как показано на Рисунке 2-8.43.

Рисунок 2-8.3: Цикл оттайки

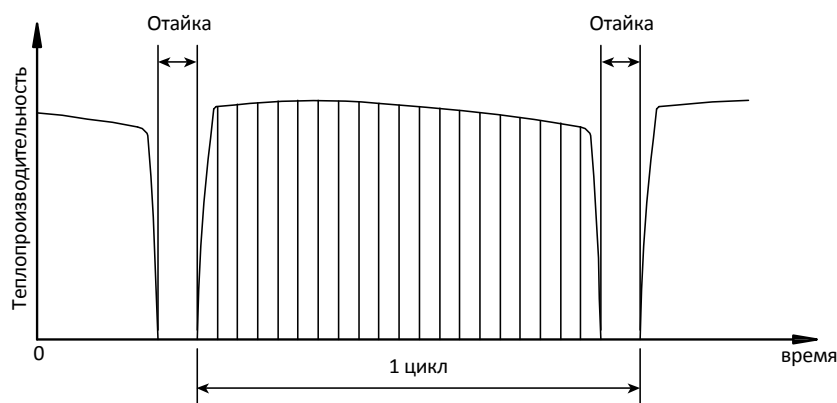

8.5 Частичная холодильная нагрузка при комбинационном соотношении 100%

Таблица 2-8.18: Частичная холодильная нагрузка для блоков производительностью 18 л.с.

Частичная нагрузка	Температура наружного воздуха (°CDB)	Температура в помещении (°C DB/WD)													
		20.8/14		23.3/16		25.8/18		27/19		28.2/20		30.7/22		32/24	
		ТС кВт	PI кВт	ТС кВт	PI кВт	ТС кВт	PI кВт	ТС кВт	PI кВт	ТС кВт	PI кВт	ТС кВт	PI кВт	ТС кВт	PI кВт
100%	-5	35.1	5.26	41.2	5.73	49.3	6.32	50.0	7.42	54.2	7.25	62.3	8.03	64.2	8.85
	-2	35.1	5.34	41.2	5.81	49.3	6.45	50.0	7.48	54.2	7.35	62.3	8.13	64.2	8.91
	0	35.1	5.39	41.2	5.88	49.3	6.56	50.0	7.59	54.2	7.42	62.3	8.28	64.2	9.01
	2	35.1	5.47	41.2	5.95	49.3	6.71	50.0	7.66	54.2	7.51	62.3	8.41	64.2	9.16
	4	35.1	5.53	41.2	6.06	49.3	6.79	50.0	7.77	54.2	7.61	62.3	8.50	64.2	9.26
	6	35.1	5.64	41.2	6.14	49.3	6.91	50.0	7.94	54.2	7.73	62.3	8.63	64.2	9.41
	8	35.1	5.73	41.2	6.27	49.3	7.04	50.0	8.08	54.2	7.86	62.3	8.78	64.2	9.57
	10	35.1	5.85	41.2	6.39	49.3	7.15	50.0	8.21	54.2	8.02	62.3	8.93	64.2	9.71
	12	35.1	5.97	41.2	6.53	49.3	7.42	50.0	8.37	54.2	8.18	62.3	9.11	63.3	9.79
	14	35.1	6.09	41.2	6.67	49.3	7.77	50.0	8.91	54.2	8.33	62.3	9.31	62.6	9.91
	16	35.1	6.20	41.2	6.83	49.3	7.96	50.0	9.13	54.2	8.51	60.5	9.43	61.7	10.03
	18	35.1	6.32	41.2	6.96	49.3	8.26	50.0	9.49	54.2	8.69	59.8	9.77	61.0	10.29
	20	35.1	6.46	41.2	7.20	49.3	8.95	50.0	10.14	54.2	9.35	58.9	10.26	60.1	10.80
	21	35.1	6.52	41.2	7.50	49.3	9.59	50.0	10.75	54.2	9.68	58.5	10.52	59.8	11.06
	23	35.1	6.98	41.2	8.09	49.3	10.31	50.0	11.49	54.2	10.41	57.8	11.03	58.9	11.57
	25	35.1	7.47	41.2	8.73	49.3	11.13	50.0	12.07	54.2	11.19	56.9	11.55	58.1	12.09
	27	35.1	7.99	41.2	9.38	49.3	11.78	50.0	12.79	54.2	12.00	56.0	12.06	57.3	12.62
	29	35.1	8.54	41.2	10.07	49.3	12.67	50.0	13.17	54.0	12.77	55.3	13.04	56.5	13.14
	31	35.1	9.14	41.2	10.81	49.3	13.55	50.0	13.41	53.3	13.29	54.4	13.51	55.6	13.67
	33	35.1	9.75	41.2	11.58	49.3	14.19	50.0	13.79	52.4	13.80	53.7	14.00	54.9	14.21
35	35.1	10.38	41.2	12.41	49.3	14.48	50.0	14.70	51.5	14.72	52.8	14.87	54.0	15.02	
37	35.1	11.08	41.2	13.28	49.3	14.59	49.4	15.37	51.0	15.59	52.1	15.78	53.1	15.99	
39	35.1	11.79	41.2	14.19	49.3	14.85	48.7	15.97	50.3	16.24	51.2	16.56	52.4	16.69	
41	35.1	12.23	41.2	14.75	49.3	15.07	48.1	16.54	49.6	16.88	49.3	17.04	51.7	17.22	
43	35.1	12.67	41.2	15.04	49.3	15.57	47.9	17.32	48.9	17.60	49.6	17.90	49.8	18.04	
45	35.1	13.26	41.2	15.45	49.3	16.55	47.6	18.42	48.2	19.44	49.2	20.42	49.0	20.81	
48	35.1	15.29	41.2	16.47	49.3	17.64	47.1	19.85	47.5	21.02	48.1	22.20	48.3	23.37	
50	35.1	17.32	41.2	18.49	49.3	19.67	46.6	20.85	46.8	22.02	47.3	23.20	47.5	24.37	
52	35.1	19.35	41.2	20.52	49.3	21.70	46.2	22.87	46.1	24.05	46.6	25.23	46.8	26.40	
54	35.1	21.38	41.2	22.55	49.3	23.73	45.8	24.90	45.4	26.08	45.9	27.26	46.1	28.43	
75%	-5	25.4	3.09	30.3	3.19	35.2	3.71	37.7	4.28	40.9	4.60	46.5	5.29	49.9	6.06
	-2	25.4	3.13	30.3	3.22	35.2	3.76	37.7	4.30	40.9	4.66	46.5	5.34	49.9	6.12
	0	25.4	3.16	30.3	3.27	35.2	3.82	37.7	4.32	40.9	4.72	46.5	5.40	49.9	6.17
	2	25.4	3.21	30.3	3.31	35.2	3.86	37.7	4.44	40.9	4.79	46.5	5.52	49.9	6.26
	4	25.4	3.24	30.3	3.36	35.2	3.93	37.7	4.51	40.9	4.85	46.5	5.60	49.9	6.35
	6	25.4	3.31	30.3	3.43	35.2	4.01	37.7	4.60	40.9	4.94	46.5	5.69	49.9	6.46
	8	25.4	3.36	30.3	3.50	35.2	4.10	37.7	4.67	40.9	5.02	46.5	5.80	49.9	6.52
	10	25.4	3.43	30.3	3.58	35.2	4.17	37.7	4.76	40.9	5.14	46.5	5.87	49.9	6.62
	12	25.4	3.50	30.3	3.65	35.2	4.26	37.7	4.84	40.9	5.23	46.5	5.98	49.9	6.74
	14	25.4	3.57	30.3	3.72	35.2	4.34	37.7	5.00	40.9	5.33	46.5	6.09	49.9	6.87
	16	25.4	3.64	30.3	3.78	35.2	4.43	37.7	5.02	40.9	5.44	46.5	6.21	49.9	6.99
	18	25.4	3.71	30.3	3.87	35.2	4.51	37.7	5.03	40.9	5.55	46.5	6.34	49.9	7.21
	20	25.4	3.79	30.3	3.96	35.2	4.61	37.7	5.36	40.9	5.75	46.5	6.81	49.9	7.55
	21	25.4	3.82	30.3	3.99	35.2	4.69	37.7	5.74	40.9	5.96	46.5	7.06	49.9	7.72
	23	25.4	4.09	30.3	4.15	35.2	5.04	37.7	6.05	40.9	6.39	46.5	7.57	49.9	8.08
	25	25.4	4.38	30.3	4.45	35.2	5.41	37.7	6.50	40.9	6.83	46.5	8.10	49.9	8.43
	27	25.4	4.68	30.3	4.75	35.2	5.79	37.7	6.96	40.9	7.30	46.5	8.67	49.9	8.78
	29	25.4	5.01	30.3	5.08	35.2	6.20	37.7	7.29	40.9	7.80	46.5	9.07	49.9	9.14
	31	25.4	5.36	30.3	5.42	35.2	6.62	37.7	7.77	40.9	8.32	46.5	9.42	49.9	9.50
	33	25.4	5.72	30.3	5.77	35.2	7.08	37.7	8.24	40.9	8.88	46.5	9.79	49.9	9.86
35	25.4	6.09	30.3	6.15	35.2	7.56	37.7	8.62	40.9	9.46	46.5	10.14	49.9	10.22	
37	25.4	6.50	30.3	6.54	35.2	8.06	37.7	9.01	40.9	10.09	46.5	10.50	49.9	10.58	
39	25.4	6.91	30.3	6.98	35.2	8.59	37.7	9.36	40.9	10.76	46.5	10.86	49.9	10.94	
41	25.4	7.17	30.3	7.30	35.2	8.92	37.7	9.70	40.9	10.81	46.5	11.14	49.9	11.20	
43	25.4	7.43	30.3	7.63	35.2	9.24	37.7	10.16	40.9	11.04	46.5	11.28	49.9	11.38	
45	25.4	7.78	30.3	8.01	35.2	9.63	37.7	10.80	40.9	11.34	46.5	12.26	49.9	12.79	
48	25.4	8.97	30.3	9.83	35.2	10.69	37.7	11.55	40.9	12.41	46.5	13.28	49.9	14.14	
50	25.4	10.16	30.3	11.02	35.2	11.88	37.7	12.74	40.9	13.60	46.5	14.47	49.9	15.33	
52	25.4	11.34	30.3	12.21	35.2	13.07	37.7	13.93	40.9	14.79	46.5	15.65	49.9	16.52	
54	25.4	12.53	30.3	13.40	35.2	14.26	37.7	15.12	40.9	15.98	46.5	16.84	49.9	17.71	

Обозначения:

ТС: Полная производительность (кВт)

PI: Потребляемая мощность (компрессор + двигатель вентилятора наружного блока) (кВт)

Продолжение таблицы на следующей странице...

Таблица 2-8.18: Частичная холодильная нагрузка для блоков производительностью 18 л.с. (продолжение)

Частичная нагрузка	Температура наружного воздуха (°CDB)	Температура в помещении (°C DB/WD)													
		20.8/14		23.3/16		25.8/18		27/19		28.2/20		30.7/22		32/24	
		ТС кВт	PI кВт	ТС кВт	PI кВт	ТС кВт	PI кВт	ТС кВт	PI кВт	ТС кВт	PI кВт	ТС кВт	PI кВт	ТС кВт	PI кВт
50%	-5	17.0	1.73	20.3	1.88	23.6	2.08	25.3	2.66	27.4	2.90	31.2	3.22	33.5	3.69
	-2	17.0	1.75	20.3	1.91	23.6	2.10	25.3	2.69	27.4	2.94	31.2	3.27	33.5	3.72
	0	17.0	1.77	20.3	1.93	23.6	2.14	25.3	2.73	27.4	2.98	31.2	3.32	33.5	3.77
	2	17.0	1.80	20.3	1.96	23.6	2.16	25.3	2.78	27.4	3.03	31.2	3.38	33.5	3.81
	4	17.0	1.82	20.3	1.99	23.6	2.20	25.3	2.81	27.4	3.09	31.2	3.44	33.5	3.87
	6	17.0	1.85	20.3	2.02	23.6	2.24	25.3	2.88	27.4	3.15	31.2	3.51	33.5	3.96
	8	17.0	1.88	20.3	2.06	23.6	2.29	25.3	2.93	27.4	3.21	31.2	3.57	33.5	4.02
	10	17.0	1.92	20.3	2.10	23.6	2.34	25.3	3.01	27.4	3.27	31.2	3.64	33.5	4.01
	12	17.0	1.96	20.3	2.14	23.6	2.38	25.3	3.07	27.4	3.33	31.2	3.71	33.5	4.08
	14	17.0	2.00	20.3	2.19	23.6	2.43	25.3	3.12	27.4	3.39	31.2	3.77	33.5	4.15
	16	17.0	2.04	20.3	2.24	23.6	2.48	25.3	3.17	27.4	3.45	31.2	3.84	33.5	4.23
	18	17.0	2.08	20.3	2.29	23.6	2.53	25.3	3.23	27.4	3.52	31.2	3.91	33.5	4.31
	20	17.0	2.12	20.3	2.36	23.6	2.58	25.3	3.29	27.4	3.55	31.2	3.99	33.5	4.39
	21	17.0	2.14	20.3	2.46	23.6	2.63	25.3	3.53	27.4	3.61	31.2	4.03	33.5	4.48
	23	17.0	2.29	20.3	2.66	23.6	2.82	25.3	3.77	27.4	3.84	31.2	4.19	33.5	4.52
	25	17.0	2.45	20.3	2.87	23.6	3.03	25.3	3.98	27.4	4.09	31.2	4.47	33.5	4.81
	27	17.0	2.62	20.3	3.08	23.6	3.24	25.3	4.17	27.4	4.36	31.2	4.76	33.5	5.13
	29	17.0	2.81	20.3	3.31	23.6	3.47	25.3	4.35	27.4	4.64	31.2	5.08	33.5	5.48
	31	17.0	3.00	20.3	3.55	23.6	3.71	25.3	4.59	27.4	4.93	31.2	5.40	33.5	5.85
	33	17.0	3.20	20.3	3.80	23.6	3.97	25.3	4.79	27.4	5.24	31.2	5.75	33.5	6.23
	35	17.0	3.41	20.3	4.08	23.6	4.23	25.3	4.83	27.4	5.56	31.2	6.12	33.5	6.64
	37	17.0	3.64	20.3	4.36	23.6	4.52	25.3	5.05	27.4	5.91	31.2	6.51	33.5	7.07
	39	17.0	3.87	20.3	4.66	23.6	4.81	25.3	5.24	27.4	6.13	31.2	6.91	33.5	7.52
	41	17.0	4.02	20.3	4.84	23.6	4.99	25.3	5.43	27.4	6.34	31.2	7.23	33.5	8.00
43	17.0	4.16	20.3	4.94	23.6	5.17	25.3	5.69	27.4	6.65	31.2	7.54	33.5	8.36	
45	17.0	4.50	20.3	5.56	23.6	5.87	25.3	6.20	27.4	7.19	31.2	7.88	33.5	8.73	
48	17.0	5.17	20.3	5.79	23.6	6.42	25.3	7.05	27.4	7.68	31.2	8.30	33.5	8.93	
50	17.0	5.83	20.3	6.46	23.6	7.09	25.3	7.71	27.4	8.34	31.2	8.97	33.5	9.60	
52	17.0	6.50	20.3	7.13	23.6	7.75	25.3	8.38	27.4	9.01	31.2	9.64	33.5	10.26	
54	17.0	7.16	20.3	7.79	23.6	8.42	25.3	9.05	27.4	9.67	31.2	10.30	33.5	10.93	
25%	-5	8.5	0.94	10.1	1.02	11.8	1.13	12.6	1.55	13.6	1.60	15.5	1.83	16.7	1.97
	-2	8.5	0.95	10.1	1.04	11.8	1.14	12.6	1.59	13.6	1.63	15.5	1.85	16.7	1.99
	0	8.5	0.96	10.1	1.05	11.8	1.16	12.6	1.59	13.6	1.65	15.5	1.88	16.7	2.03
	2	8.5	0.98	10.1	1.06	11.8	1.17	12.6	1.60	13.6	1.68	15.5	1.89	16.7	2.07
	4	8.5	0.99	10.1	1.08	11.8	1.20	12.6	1.60	13.6	1.72	15.5	1.94	16.7	2.12
	6	8.5	1.01	10.1	1.10	11.8	1.22	12.6	1.61	13.6	1.75	15.5	1.97	16.7	2.18
	8	8.5	1.02	10.1	1.12	11.8	1.25	12.6	1.62	13.6	1.77	15.5	2.00	16.7	2.25
	10	8.5	1.04	10.1	1.14	11.8	1.27	12.6	1.61	13.6	1.82	15.5	2.05	16.7	2.29
	12	8.5	1.06	10.1	1.16	11.8	1.29	12.6	1.61	13.6	1.86	15.5	2.09	16.7	2.32
	14	8.5	1.09	10.1	1.19	11.8	1.32	12.6	1.62	13.6	1.89	15.5	2.12	16.7	2.37
	16	8.5	1.11	10.1	1.22	11.8	1.35	12.6	1.63	13.6	1.91	15.5	2.16	16.7	2.40
	18	8.5	1.13	10.1	1.24	11.8	1.37	12.6	1.63	13.6	1.95	15.5	2.19	16.7	2.45
	20	8.5	1.15	10.1	1.28	11.8	1.40	12.6	1.71	13.6	1.98	15.5	2.23	16.7	2.50
	21	8.5	1.16	10.1	1.34	11.8	1.43	12.6	1.80	13.6	2.00	15.5	2.26	16.7	2.52
	23	8.5	1.24	10.1	1.44	11.8	1.53	12.6	1.92	13.6	2.04	15.5	2.29	16.7	2.58
	25	8.5	1.33	10.1	1.56	11.8	1.65	12.6	2.04	13.6	2.10	15.5	2.41	16.7	2.75
	27	8.5	1.42	10.1	1.67	11.8	1.76	12.6	2.20	13.6	2.23	15.5	2.57	16.7	2.93
	29	8.5	1.52	10.1	1.80	11.8	1.89	12.6	2.27	13.6	2.38	15.5	2.73	16.7	3.12
	31	8.5	1.63	10.1	1.93	11.8	2.01	12.6	2.42	13.6	2.52	15.5	2.90	16.7	3.32
	33	8.5	1.74	10.1	2.07	11.8	2.15	12.6	2.55	13.6	2.68	15.5	3.09	16.7	3.53
	35	8.5	1.85	10.1	2.21	11.8	2.30	12.6	2.62	13.6	2.83	15.5	3.28	16.7	3.75
	37	8.5	1.98	10.1	2.37	11.8	2.45	12.6	2.74	13.6	3.00	15.5	3.48	16.7	3.99
	39	8.5	2.10	10.1	2.53	11.8	2.61	12.6	2.85	13.6	3.19	15.5	3.69	16.7	4.23
	41	8.5	2.18	10.1	2.63	11.8	2.71	12.6	2.95	13.6	3.32	15.5	3.88	16.7	4.43
43	8.5	2.26	10.1	2.68	11.8	2.81	12.6	3.14	13.6	3.41	15.5	4.08	16.7	4.63	
45	8.5	2.37	10.1	3.02	11.8	3.22	12.6	3.47	13.6	3.81	15.5	4.47	16.7	4.82	
48	8.5	2.78	10.1	3.17	11.8	3.57	12.6	3.96	13.6	4.35	15.5	4.75	16.7	5.14	
50	8.5	3.19	10.1	3.59	11.8	3.98	12.6	4.37	13.6	4.77	15.5	5.16	16.7	5.55	
52	8.5	3.61	10.1	4.00	11.8	4.40	12.6	4.79	13.6	5.18	15.5	5.58	16.7	5.97	
54	8.5	4.02	10.1	4.42	11.8	4.81	12.6	5.20	13.6	5.60	15.5	5.99	16.7	6.38	

Обозначения:

ТС: Полная производительность (кВт)

PI: Потребляемая мощность (компрессор + двигатель вентилятора наружного блока) (кВт)

Таблица 2-8.19: Частичная холодильная нагрузка для блоков производительностью 20 л.с.

Частичная нагрузка	Температура наружного воздуха (°CDB)	Температура в помещении (°C DB/WD)													
		20.8/14		23.3/16		25.8/18		27/19		28.2/20		30.7/22		32/24	
		ТС кВт	PI кВт	ТС кВт	PI кВт	ТС кВт	PI кВт	ТС кВт	PI кВт	ТС кВт	PI кВт	ТС кВт	PI кВт	ТС кВт	PI кВт
100%	-5	39.3	5.73	46.1	6.24	55.2	6.88	56.0	8.08	60.7	7.89	69.8	8.74	71.9	9.63
	-2	39.3	5.81	46.1	6.32	55.2	7.02	56.0	8.14	60.7	8.00	69.8	8.85	71.9	9.70
	0	39.3	5.87	46.1	6.40	55.2	7.14	56.0	8.26	60.7	8.08	69.8	9.01	71.9	9.81
	2	39.3	5.96	46.1	6.48	55.2	7.30	56.0	8.34	60.7	8.18	69.8	9.15	71.9	9.97
	4	39.3	6.02	46.1	6.59	55.2	7.39	56.0	8.46	60.7	8.29	69.8	9.25	71.9	10.08
	6	39.3	6.14	46.1	6.69	55.2	7.52	56.0	8.64	60.7	8.42	69.8	9.39	71.9	10.24
	8	39.3	6.24	46.1	6.83	55.2	7.66	56.0	8.80	60.7	8.56	69.8	9.55	71.9	10.42
	10	39.3	6.36	46.1	6.95	55.2	7.78	56.0	8.93	60.7	8.73	69.8	9.72	71.9	10.57
	12	39.3	6.49	46.1	7.10	55.2	8.08	56.0	9.11	60.7	8.90	69.8	9.92	70.9	10.65
	14	39.3	6.62	46.1	7.26	55.2	8.45	56.0	9.69	60.7	9.07	69.8	10.13	70.1	10.79
	16	39.3	6.75	46.1	7.43	55.2	8.66	56.0	9.94	60.7	9.27	67.7	10.26	69.1	10.92
	18	39.3	6.88	46.1	7.58	55.2	8.99	56.0	10.33	60.7	9.46	66.9	10.63	68.3	11.20
	20	39.3	7.03	46.1	7.84	55.2	9.74	56.0	11.03	60.7	10.17	65.9	11.17	67.3	11.76
	21	39.3	7.10	46.1	8.16	55.2	10.43	56.0	11.70	60.7	10.54	65.5	11.45	66.9	12.04
	23	39.3	7.59	46.1	8.81	55.2	11.22	56.0	12.51	60.7	11.34	64.7	12.01	65.9	12.60
	25	39.3	8.13	46.1	9.50	55.2	12.11	56.0	13.14	60.7	12.18	63.7	12.57	65.1	13.16
	27	39.3	8.69	46.1	10.21	55.2	12.82	56.0	13.93	60.7	13.06	62.7	13.13	64.1	13.74
	29	39.3	9.30	46.1	10.96	55.2	13.79	56.0	14.34	60.5	13.90	61.9	14.19	63.3	14.30
	31	39.3	9.94	46.1	11.76	55.2	14.74	56.0	14.60	59.7	14.46	60.9	14.70	62.3	14.88
	33	39.3	10.61	46.1	12.60	55.2	15.45	56.0	15.01	58.7	15.02	60.1	15.24	61.5	15.46
	35	39.3	11.30	46.1	13.51	55.2	15.76	56.0	16.00	57.7	16.03	59.1	16.19	60.5	16.35
	37	39.3	12.06	46.1	14.46	55.2	15.88	55.3	16.73	57.1	16.97	58.3	17.18	59.5	17.41
	39	39.3	12.83	46.1	15.45	55.2	16.16	54.6	17.38	56.4	17.67	57.3	18.02	58.7	18.17
	41	39.3	13.31	46.1	16.05	55.2	16.40	53.9	18.00	55.6	18.37	55.2	18.54	57.9	18.74
	43	39.3	13.79	46.1	16.36	55.2	16.95	53.7	18.86	54.8	19.16	55.6	19.48	55.8	19.63
45	39.3	14.43	46.1	16.82	55.2	18.01	53.3	20.05	54.0	21.16	55.1	22.22	54.9	22.65	
48	39.3	16.64	46.1	17.92	55.2	19.20	52.7	21.60	53.2	22.88	53.8	24.16	54.0	25.44	
50	39.3	18.85	46.1	20.13	55.2	21.41	52.2	22.69	52.5	23.97	53.0	25.25	53.2	26.53	
52	39.3	21.06	46.1	22.34	55.2	23.62	51.8	24.90	51.7	26.18	52.2	27.46	52.4	28.74	
54	39.3	23.27	46.1	24.55	55.2	25.83	51.3	27.11	50.9	28.39	51.4	29.67	51.6	30.95	
75%	-5	28.4	3.36	34.0	3.47	39.4	4.03	42.2	4.66	45.8	5.01	52.0	5.76	55.9	6.60
	-2	28.4	3.41	34.0	3.51	39.4	4.09	42.2	4.68	45.8	5.07	52.0	5.82	55.9	6.66
	0	28.4	3.44	34.0	3.56	39.4	4.16	42.2	4.70	45.8	5.14	52.0	5.88	55.9	6.71
	2	28.4	3.49	34.0	3.60	39.4	4.20	42.2	4.83	45.8	5.22	52.0	6.00	55.9	6.81
	4	28.4	3.53	34.0	3.66	39.4	4.28	42.2	4.91	45.8	5.28	52.0	6.10	55.9	6.91
	6	28.4	3.60	34.0	3.73	39.4	4.36	42.2	5.00	45.8	5.38	52.0	6.19	55.9	7.03
	8	28.4	3.66	34.0	3.81	39.4	4.46	42.2	5.09	45.8	5.47	52.0	6.31	55.9	7.09
	10	28.4	3.73	34.0	3.90	39.4	4.54	42.2	5.18	45.8	5.59	52.0	6.39	55.9	7.21
	12	28.4	3.81	34.0	3.97	39.4	4.63	42.2	5.27	45.8	5.70	52.0	6.51	55.9	7.34
	14	28.4	3.88	34.0	4.04	39.4	4.72	42.2	5.44	45.8	5.80	52.0	6.63	55.9	7.47
	16	28.4	3.96	34.0	4.12	39.4	4.82	42.2	5.46	45.8	5.92	52.0	6.76	55.9	7.61
	18	28.4	4.04	34.0	4.21	39.4	4.91	42.2	5.48	45.8	6.04	52.0	6.90	55.9	7.84
	20	28.4	4.12	34.0	4.31	39.4	5.02	42.2	5.83	45.8	6.26	52.0	7.41	55.9	8.21
	21	28.4	4.16	34.0	4.34	39.4	5.10	42.2	6.25	45.8	6.48	52.0	7.68	55.9	8.41
	23	28.4	4.45	34.0	4.52	39.4	5.49	42.2	6.59	45.8	6.96	52.0	8.24	55.9	8.79
	25	28.4	4.77	34.0	4.84	39.4	5.89	42.2	7.07	45.8	7.43	52.0	8.82	55.9	9.18
	27	28.4	5.10	34.0	5.17	39.4	6.30	42.2	7.58	45.8	7.95	52.0	9.44	55.9	9.56
	29	28.4	5.45	34.0	5.52	39.4	6.75	42.2	7.93	45.8	8.49	52.0	9.87	55.9	9.94
	31	28.4	5.83	34.0	5.89	39.4	7.21	42.2	8.46	45.8	9.06	52.0	10.26	55.9	10.34
	33	28.4	6.22	34.0	6.28	39.4	7.71	42.2	8.97	45.8	9.66	52.0	10.65	55.9	10.73
	35	28.4	6.63	34.0	6.69	39.4	8.23	42.2	9.38	45.8	10.30	52.0	11.04	55.9	11.13
	37	28.4	7.07	34.0	7.12	39.4	8.78	42.2	9.81	45.8	10.98	52.0	11.42	55.9	11.51
	39	28.4	7.53	34.0	7.60	39.4	9.35	42.2	10.19	45.8	11.71	52.0	11.82	55.9	11.91
	41	28.4	7.81	34.0	7.95	39.4	9.70	42.2	10.56	45.8	11.76	52.0	12.13	55.9	12.19
	43	28.4	8.09	34.0	8.30	39.4	10.06	42.2	11.06	45.8	12.01	52.0	12.28	55.9	12.38
45	28.4	8.46	34.0	8.72	39.4	10.48	42.2	11.76	45.8	12.35	52.0	13.35	55.9	13.92	
48	28.4	9.76	34.0	10.70	39.4	11.64	42.2	12.57	45.8	13.51	52.0	14.45	55.9	15.39	
50	28.4	11.05	34.0	11.99	39.4	12.93	42.2	13.87	45.8	14.81	52.0	15.74	55.9	16.68	
52	28.4	12.35	34.0	13.29	39.4	14.22	42.2	15.16	45.8	16.10	52.0	17.04	55.9	17.98	
54	28.4	13.64	34.0	14.58	39.4	15.52	42.2	16.46	45.8	17.40	52.0	18.33	55.9	19.27	

Обозначения:

ТС: Полная производительность (кВт)

PI: Потребляемая мощность (компрессор + двигатель вентилятора наружного блока) (кВт)

Продолжение таблицы
на следующей странице...

Таблица 2-8.19: Частичная холодильная нагрузка для блоков производительностью 20 л.с. (продолжение)

Частичная нагрузка	Температура наружного воздуха (°CDB)	Температура в помещении (°C DB/WD)													
		20.8/14		23.3/16		25.8/18		27/19		28.2/20		30.7/22		32/24	
		ТС кВт	PI кВт	ТС кВт	PI кВт	ТС кВт	PI кВт	ТС кВт	PI кВт	ТС кВт	PI кВт	ТС кВт	PI кВт	ТС кВт	PI кВт
50%	-2	19.0	1.88	22.7	2.05	26.4	2.26	28.3	2.89	30.7	3.15	35.0	3.50	37.5	4.02
	0	19.0	1.91	22.7	2.08	26.4	2.29	28.3	2.93	30.7	3.21	35.0	3.56	37.5	4.05
	2	19.0	1.93	22.7	2.10	26.4	2.33	28.3	2.97	30.7	3.25	35.0	3.61	37.5	4.10
	4	19.0	1.96	22.7	2.13	26.4	2.35	28.3	3.03	30.7	3.30	35.0	3.68	37.5	4.15
	6	19.0	1.98	22.7	2.16	26.4	2.40	28.3	3.06	30.7	3.36	35.0	3.74	37.5	4.21
	8	19.0	2.02	22.7	2.20	26.4	2.44	28.3	3.13	30.7	3.43	35.0	3.82	37.5	4.31
	10	19.0	2.05	22.7	2.24	26.4	2.50	28.3	3.19	30.7	3.50	35.0	3.89	37.5	4.38
	12	19.0	2.09	22.7	2.28	26.4	2.54	28.3	3.28	30.7	3.56	35.0	3.96	37.5	4.37
	14	19.0	2.13	22.7	2.33	26.4	2.59	28.3	3.34	30.7	3.63	35.0	4.04	37.5	4.44
	16	19.0	2.18	22.7	2.38	26.4	2.64	28.3	3.40	30.7	3.69	35.0	4.11	37.5	4.51
	18	19.0	2.22	22.7	2.44	26.4	2.70	28.3	3.45	30.7	3.76	35.0	4.18	37.5	4.60
	20	19.0	2.26	22.7	2.49	26.4	2.75	28.3	3.51	30.7	3.83	35.0	4.25	37.5	4.69
	21	19.0	2.31	22.7	2.57	26.4	2.81	28.3	3.59	30.7	3.86	35.0	4.34	37.5	4.78
	23	19.0	2.33	22.7	2.68	26.4	2.86	28.3	3.84	30.7	3.93	35.0	4.38	37.5	4.88
	25	19.0	2.49	22.7	2.89	26.4	3.07	28.3	4.11	30.7	4.18	35.0	4.56	37.5	4.92
	27	19.0	2.67	22.7	3.12	26.4	3.30	28.3	4.33	30.7	4.46	35.0	4.86	37.5	5.24
	29	19.0	2.85	22.7	3.35	26.4	3.53	28.3	4.54	30.7	4.75	35.0	5.18	37.5	5.59
	31	19.0	3.05	22.7	3.60	26.4	3.78	28.3	4.74	30.7	5.05	35.0	5.53	37.5	5.97
	33	19.0	3.27	22.7	3.86	26.4	4.04	28.3	5.00	30.7	5.37	35.0	5.88	37.5	6.37
	35	19.0	3.49	22.7	4.14	26.4	4.32	28.3	5.21	30.7	5.70	35.0	6.26	37.5	6.78
	37	19.0	3.71	22.7	4.44	26.4	4.61	28.3	5.25	30.7	6.05	35.0	6.66	37.5	7.23
	39	19.0	3.96	22.7	4.75	26.4	4.91	28.3	5.49	30.7	6.43	35.0	7.08	37.5	7.69
	41	19.0	4.21	22.7	5.07	26.4	5.24	28.3	5.71	30.7	6.67	35.0	7.52	37.5	8.19
43	19.0	4.37	22.7	5.27	26.4	5.43	28.3	5.91	30.7	6.90	35.0	7.87	37.5	8.71	
45	19.0	4.53	22.7	5.37	26.4	5.63	28.3	6.19	30.7	7.24	35.0	8.21	37.5	9.10	
48	19.0	4.90	22.7	6.05	26.4	6.39	28.3	6.74	30.7	7.83	35.0	8.58	37.5	9.50	
50	19.0	5.62	22.7	6.31	26.4	6.99	28.3	7.67	30.7	8.36	35.0	9.04	37.5	9.72	
52	19.0	6.35	22.7	7.03	26.4	7.71	28.3	8.40	30.7	9.08	35.0	9.76	37.5	10.45	
54	19.0	7.07	22.7	7.76	26.4	8.44	28.3	9.12	30.7	9.81	35.0	10.49	37.5	11.17	
54	19.0	7.80	22.7	8.48	26.4	9.16	28.3	9.85	30.7	10.53	35.0	11.21	37.5	11.90	
25%	-5	9.5	1.02	11.4	1.11	13.2	1.23	14.1	1.68	15.3	1.75	17.4	1.99	18.7	2.14
	-2	9.5	1.04	11.4	1.13	13.2	1.24	14.1	1.73	15.3	1.78	17.4	2.01	18.7	2.17
	0	9.5	1.05	11.4	1.14	13.2	1.26	14.1	1.73	15.3	1.80	17.4	2.05	18.7	2.21
	2	9.5	1.06	11.4	1.16	13.2	1.28	14.1	1.74	15.3	1.83	17.4	2.06	18.7	2.25
	4	9.5	1.07	11.4	1.18	13.2	1.30	14.1	1.74	15.3	1.87	17.4	2.11	18.7	2.31
	6	9.5	1.10	11.4	1.19	13.2	1.33	14.1	1.76	15.3	1.90	17.4	2.14	18.7	2.37
	8	9.5	1.11	11.4	1.22	13.2	1.36	14.1	1.76	15.3	1.93	17.4	2.17	18.7	2.45
	10	9.5	1.14	11.4	1.24	13.2	1.38	14.1	1.75	15.3	1.98	17.4	2.23	18.7	2.49
	12	9.5	1.16	11.4	1.27	13.2	1.41	14.1	1.76	15.3	2.02	17.4	2.27	18.7	2.53
	14	9.5	1.18	11.4	1.29	13.2	1.44	14.1	1.77	15.3	2.05	17.4	2.31	18.7	2.58
	16	9.5	1.20	11.4	1.33	13.2	1.47	14.1	1.77	15.3	2.08	17.4	2.35	18.7	2.62
	18	9.5	1.23	11.4	1.35	13.2	1.49	14.1	1.78	15.3	2.12	17.4	2.39	18.7	2.67
	20	9.5	1.25	11.4	1.40	13.2	1.53	14.1	1.86	15.3	2.16	17.4	2.43	18.7	2.72
	21	9.5	1.27	11.4	1.46	13.2	1.55	14.1	1.96	15.3	2.18	17.4	2.46	18.7	2.75
	23	9.5	1.35	11.4	1.57	13.2	1.67	14.1	2.09	15.3	2.22	17.4	2.50	18.7	2.80
	25	9.5	1.45	11.4	1.69	13.2	1.79	14.1	2.22	15.3	2.29	17.4	2.63	18.7	2.99
	27	9.5	1.55	11.4	1.82	13.2	1.92	14.1	2.40	15.3	2.43	17.4	2.80	18.7	3.19
	29	9.5	1.66	11.4	1.96	13.2	2.05	14.1	2.47	15.3	2.59	17.4	2.97	18.7	3.40
	31	9.5	1.77	11.4	2.10	13.2	2.19	14.1	2.63	15.3	2.75	17.4	3.16	18.7	3.62
	33	9.5	1.89	11.4	2.25	13.2	2.35	14.1	2.77	15.3	2.91	17.4	3.36	18.7	3.85
	35	9.5	2.02	11.4	2.41	13.2	2.50	14.1	2.85	15.3	3.08	17.4	3.57	18.7	4.08
	37	9.5	2.15	11.4	2.58	13.2	2.67	14.1	2.98	15.3	3.27	17.4	3.79	18.7	4.34
	39	9.5	2.29	11.4	2.76	13.2	2.85	14.1	3.10	15.3	3.47	17.4	4.01	18.7	4.61
41	9.5	2.38	11.4	2.86	13.2	2.95	14.1	3.21	15.3	3.62	17.4	4.23	18.7	4.82	
43	9.5	2.46	11.4	2.92	13.2	3.06	14.1	3.42	15.3	3.71	17.4	4.44	18.7	5.04	
45	9.5	2.57	11.4	3.29	13.2	3.50	14.1	3.78	15.3	4.15	17.4	4.87	18.7	5.25	
48	9.5	3.03	11.4	3.45	13.2	3.88	14.1	4.31	15.3	4.74	17.4	5.17	18.7	5.59	
50	9.5	3.48	11.4	3.91	13.2	4.33	14.1	4.76	15.3	5.19	17.4	5.62	18.7	6.05	
52	9.5	3.93	11.4	4.36	13.2	4.78	14.1	5.21	15.3	5.64	17.4	6.07	18.7	6.50	
54	9.5	4.38	11.4	4.81	13.2	5.24	14.1	5.66	15.3	6.09	17.4	6.52	18.7	6.95	

Обозначения:

ТС: Полная производительность (кВт)

PI: Потребляемая мощность (компрессор + двигатель вентилятора наружного блока) (кВт)

Продолжение таблицы
на следующей странице...

MVS FDC II-S

Таблица 2-8.20: Частичная холодильная нагрузка для блоков производительностью 22 л.с.

Частичная нагрузка	Температура наружного воздуха (°CDB)	Температура в помещении (°C DB/WD)													
		20.8/14		23.3/16		25.8/18		27/19		28.2/20		30.7/22		32/24	
		ТС	PI	ТС	PI	ТС	PI	ТС	PI	ТС	PI	ТС	PI	ТС	PI
		кВт	кВт	кВт	кВт	кВт	кВт	кВт	кВт	кВт	кВт	кВт	кВт	кВт	кВт
100%	-5	43.1	7.22	50.7	7.86	60.6	8.67	61.5	10.18	66.7	9.94	76.7	11.01	79.0	12.14
	-2	43.1	7.32	50.7	7.96	60.6	8.85	61.5	10.26	66.7	10.08	76.7	11.15	79.0	12.22
	0	43.1	7.40	50.7	8.06	60.6	8.99	61.5	10.41	66.7	10.18	76.7	11.35	79.0	12.36
	2	43.1	7.51	50.7	8.16	60.6	9.20	61.5	10.51	66.7	10.30	76.7	11.53	79.0	12.56
	4	43.1	7.58	50.7	8.31	60.6	9.32	61.5	10.66	66.7	10.44	76.7	11.65	79.0	12.70
	6	43.1	7.74	50.7	8.43	60.6	9.48	61.5	10.89	66.7	10.60	76.7	11.83	79.0	12.90
	8	43.1	7.86	50.7	8.60	60.6	9.65	61.5	11.09	66.7	10.79	76.7	12.04	79.0	13.12
	10	43.1	8.02	50.7	8.76	60.6	9.81	61.5	11.26	66.7	11.00	76.7	12.25	79.0	13.32
	12	43.1	8.18	50.7	8.95	60.6	10.18	61.5	11.48	66.7	11.22	76.7	12.50	77.9	13.42
	14	43.1	8.35	50.7	9.14	60.6	10.65	61.5	12.21	66.7	11.43	76.7	12.77	77.0	13.59
	16	43.1	8.51	50.7	9.36	60.6	10.91	61.5	12.52	66.7	11.68	74.4	12.93	75.9	13.75
	18	43.1	8.67	50.7	9.55	60.6	11.33	61.5	13.01	66.7	11.92	73.5	13.39	75.0	14.11
	20	43.1	8.86	50.7	9.88	60.6	12.27	61.5	13.90	66.7	12.82	72.4	14.07	73.9	14.81
	21	43.1	8.94	50.7	10.28	60.6	13.15	61.5	14.75	66.7	13.28	72.0	14.42	73.5	15.16
	23	43.1	9.57	50.7	11.10	60.6	14.14	61.5	15.76	66.7	14.28	71.1	15.13	72.4	15.87
	25	43.1	10.25	50.7	11.97	60.6	15.26	61.5	16.55	66.7	15.34	70.0	15.84	71.5	16.58
	27	43.1	10.95	50.7	12.86	60.6	16.16	61.5	17.55	66.7	16.46	68.9	16.54	70.4	17.31
	29	43.1	11.71	50.7	13.82	60.6	17.37	61.5	18.07	66.5	17.52	68.0	17.28	69.5	18.02
	31	43.1	12.53	50.7	14.82	60.6	18.58	61.5	18.40	65.6	18.22	66.9	17.98	68.4	18.75
	33	43.1	13.37	50.7	15.88	60.6	19.46	61.5	18.92	64.5	18.93	66.0	18.69	67.6	19.48
	35	43.1	14.24	50.7	17.02	60.6	19.86	61.5	20.16	63.4	19.64	64.9	19.42	66.5	20.19
	37	43.1	15.19	50.7	18.22	60.6	20.00	60.7	20.27	62.8	20.37	64.0	20.15	65.4	20.93
	39	43.1	16.17	50.7	19.47	60.6	20.36	59.9	20.36	61.9	21.08	63.0	20.86	64.5	21.69
	41	43.1	16.78	50.7	20.22	60.6	20.67	59.2	20.67	61.0	21.41	60.6	21.38	63.6	22.14
43	43.1	17.38	50.7	20.62	60.6	20.81	59.0	20.81	60.2	21.62	61.0	21.52	61.2	22.39	
45	43.1	18.19	50.7	20.99	60.6	21.00	58.6	21.00	59.3	22.03	60.5	21.87	60.0	22.69	
48	43.1	18.90	50.7	21.92	60.6	21.30	57.9	21.20	58.5	22.46	59.1	22.39	58.7	23.24	
50	43.1	19.68	50.7	22.47	60.6	21.53	57.4	21.39	57.6	22.87	58.3	22.79	57.5	23.62	
52	43.1	20.44	50.7	23.12	60.6	21.78	56.9	21.58	56.8	23.29	57.4	23.22	56.3	24.05	
54	43.1	21.20	50.7	23.77	60.6	22.02	56.3	21.77	55.9	23.71	56.4	23.65	55.0	24.47	
75%	-5	31.1	2.99	37.2	3.51	43.1	3.81	46.2	4.07	50.1	4.55	57.0	5.20	61.2	5.98
	-2	31.1	3.02	37.2	3.52	43.1	3.83	46.2	4.09	50.1	4.63	57.0	5.28	61.2	6.06
	0	31.1	3.03	37.2	3.57	43.1	3.92	46.2	4.11	50.1	4.71	57.0	5.39	61.2	6.14
	2	31.1	3.05	37.2	3.59	43.1	3.98	46.2	4.22	50.1	4.79	57.0	5.51	61.2	6.24
	4	31.1	3.09	37.2	3.68	43.1	4.07	46.2	4.29	50.1	4.90	57.0	5.60	61.2	6.39
	6	31.1	3.14	37.2	3.74	43.1	4.18	46.2	4.37	50.1	5.01	57.0	5.69	61.2	6.51
	8	31.1	3.20	37.2	3.85	43.1	4.28	46.2	4.44	50.1	5.12	57.0	5.86	61.2	6.64
	10	31.1	3.26	37.2	3.91	43.1	4.39	46.2	4.52	50.1	5.26	57.0	5.98	61.2	6.72
	12	31.1	3.34	37.2	3.97	43.1	4.49	46.2	4.60	50.1	5.35	57.0	6.09	61.2	6.85
	14	31.1	3.40	37.2	4.04	43.1	4.56	46.2	4.75	50.1	5.44	57.0	6.20	61.2	6.98
	16	31.1	3.45	37.2	4.12	43.1	4.65	46.2	4.77	50.1	5.55	57.0	6.31	61.2	7.10
	18	31.1	3.51	37.2	4.19	43.1	4.74	46.2	4.78	50.1	5.65	57.0	6.44	61.2	7.25
	20	31.1	3.56	37.2	4.26	43.1	4.84	46.2	5.09	50.1	5.76	57.0	6.57	61.2	7.45
	21	31.1	3.60	37.2	4.30	43.1	4.87	46.2	5.46	50.1	5.81	57.0	6.66	61.2	7.71
	23	31.1	3.65	37.2	4.37	43.1	4.98	46.2	5.75	50.1	6.11	57.0	7.14	61.2	8.27
	25	31.1	3.73	37.2	4.56	43.1	5.32	46.2	6.18	50.1	6.51	57.0	7.64	61.2	8.84
	27	31.1	3.95	37.2	4.85	43.1	5.69	46.2	6.62	50.1	6.96	57.0	8.16	61.2	9.45
	29	31.1	4.19	37.2	5.15	43.1	6.05	46.2	6.93	50.1	7.40	57.0	8.69	61.2	10.09
	31	31.1	4.43	37.2	5.46	43.1	6.46	46.2	7.39	50.1	7.88	57.0	9.26	61.2	10.76
	33	31.1	4.71	37.2	5.81	43.1	6.89	46.2	7.83	50.1	8.40	57.0	9.87	61.2	11.48
	35	31.1	4.98	37.2	6.16	43.1	7.31	46.2	8.19	50.1	8.93	57.0	10.52	61.2	12.23
	37	31.1	5.26	37.2	6.53	43.1	7.79	46.2	8.31	50.1	9.50	57.0	11.20	61.2	13.03
	39	31.1	5.57	37.2	6.92	43.1	8.27	46.2	8.45	50.1	10.09	57.0	11.90	61.2	13.88
	41	31.1	5.82	37.2	7.17	43.1	8.52	46.2	8.86	50.1	10.40	57.0	12.39	61.2	14.49
43	31.1	6.29	37.2	7.66	43.1	8.87	46.2	9.22	50.1	10.71	57.0	12.84	61.2	14.94	
45	31.1	6.43	37.2	7.82	43.1	9.06	46.2	9.47	50.1	11.24	57.0	13.54	61.2	15.52	
48	31.1	6.79	37.2	8.21	43.1	9.45	46.2	9.79	50.1	11.62	57.0	14.06	61.2	16.18	
50	31.1	7.01	37.2	8.45	43.1	9.70	46.2	10.06	50.1	12.10	57.0	14.70	61.2	16.79	
52	31.1	7.26	37.2	8.73	43.1	9.99	46.2	10.35	50.1	12.55	57.0	15.31	61.2	17.41	
54	31.1	7.51	37.2	9.01	43.1	10.28	46.2	10.63	50.1	13.00	57.0	15.92	61.2	18.03	

Обозначения:

ТС: Полная производительность (кВт)

PI: Потребляемая мощность (компрессор + двигатель вентилятора наружного блока) (кВт)

Продолжение таблицы на следующей странице...

Таблица 2-8.20: Частичная холодильная нагрузка для блоков производительностью 22 л.с. (продолжение)

Частичная нагрузка	Температура наружного воздуха (°C DB)	Температура в помещении (°C DB/WD)													
		20.8/14		23.3/16		25.8/18		27/19		28.2/20		30.7/22		32/24	
		ТС кВт	PI кВт	ТС кВт	PI кВт	ТС кВт	PI кВт	ТС кВт	PI кВт	ТС кВт	PI кВт	ТС кВт	PI кВт	ТС кВт	PI кВт
50%	-5	21.0	1.69	25.1	1.88	29.1	2.10	31.1	2.39	33.7	2.48	38.3	2.83	41.3	3.05
	-2	21.0	1.71	25.1	1.92	29.1	2.13	31.1	2.45	33.7	2.53	38.3	2.86	41.3	3.09
	0	21.0	1.73	25.1	1.95	29.1	2.16	31.1	2.46	33.7	2.56	38.3	2.91	41.3	3.14
	2	21.0	1.76	25.1	1.97	29.1	2.19	31.1	2.47	33.7	2.60	38.3	2.92	41.3	3.20
	4	21.0	1.78	25.1	2.01	29.1	2.23	31.1	2.48	33.7	2.66	38.3	3.00	41.3	3.28
	6	21.0	1.81	25.1	2.04	29.1	2.26	31.1	2.50	33.7	2.70	38.3	3.04	41.3	3.38
	8	21.0	1.85	25.1	2.08	29.1	2.29	31.1	2.51	33.7	2.74	38.3	3.09	41.3	3.49
	10	21.0	1.89	25.1	2.10	29.1	2.32	31.1	2.49	33.7	2.82	38.3	3.17	41.3	3.54
	12	21.0	1.90	25.1	2.13	29.1	2.36	31.1	2.50	33.7	2.88	38.3	3.23	41.3	3.59
	14	21.0	1.93	25.1	2.16	29.1	2.48	31.1	2.51	33.7	2.92	38.3	3.28	41.3	3.67
	16	21.0	1.96	25.1	2.19	29.1	2.53	31.1	2.52	33.7	2.96	38.3	3.34	41.3	3.72
	18	21.0	1.99	25.1	2.23	29.1	2.57	31.1	2.53	33.7	3.02	38.3	3.40	41.3	3.79
	20	21.0	2.02	25.1	2.26	29.1	2.61	31.1	2.57	33.7	3.07	38.3	3.45	41.3	3.86
	21	21.0	2.03	25.1	2.29	29.1	2.64	31.1	2.78	33.7	3.10	38.3	3.50	41.3	3.91
	23	21.0	2.06	25.1	2.32	29.1	2.68	31.1	2.97	33.7	3.16	38.3	3.55	41.3	3.99
	25	21.0	2.09	25.1	2.36	29.1	2.74	31.1	3.16	33.7	3.26	38.3	3.74	41.3	4.26
	27	21.0	2.13	25.1	2.46	29.1	2.89	31.1	3.41	33.7	3.45	38.3	3.98	41.3	4.54
	29	21.0	2.24	25.1	2.60	29.1	3.08	31.1	3.51	33.7	3.68	38.3	4.23	41.3	4.84
	31	21.0	2.37	25.1	2.75	29.1	3.26	31.1	3.74	33.7	3.91	38.3	4.50	41.3	5.15
	33	21.0	2.51	25.1	2.92	29.1	3.47	31.1	3.95	33.7	4.14	38.3	4.78	41.3	5.47
	35	21.0	2.65	25.1	3.09	29.1	3.67	31.1	4.06	33.7	4.39	38.3	5.08	41.3	5.81
	37	21.0	2.79	25.1	3.27	29.1	3.89	31.1	4.07	33.7	4.65	38.3	5.39	41.3	6.17
	39	21.0	2.95	25.1	3.46	29.1	4.12	31.1	4.11	33.7	4.93	38.3	5.71	41.3	6.56
	41	21.0	3.07	25.1	3.61	29.1	4.27	31.1	4.19	33.7	5.15	38.3	6.01	41.3	6.86
43	21.0	3.27	25.1	3.86	29.1	4.42	31.1	4.30	33.7	5.28	38.3	6.32	41.3	7.16	
45	21.0	3.35	25.1	3.96	29.1	4.73	31.1	4.42	33.7	5.50	38.3	6.93	41.3	7.77	
48	21.0	3.52	25.1	4.17	29.1	4.88	31.1	4.48	33.7	5.72	38.3	7.18	41.3	8.05	
50	21.0	3.62	25.1	4.31	29.1	5.13	31.1	4.59	33.7	5.94	38.3	7.67	41.3	8.55	
52	21.0	3.74	25.1	4.46	29.1	5.36	31.1	4.68	33.7	6.16	38.3	8.10	41.3	8.99	
54	21.0	3.86	25.1	4.61	29.1	5.59	31.1	4.77	33.7	6.38	38.3	8.53	41.3	9.43	
25%	-5	11.2	0.97	13.3	1.05	15.8	1.19	15.4	1.33	19.5	1.41	20.6	1.60	23.5	1.82
	-2	11.2	0.99	13.3	1.06	15.8	1.21	15.4	1.37	19.5	1.45	20.6	1.65	23.5	1.85
	0	11.2	1.00	13.3	1.08	15.8	1.23	15.4	1.40	19.5	1.48	20.6	1.68	23.5	1.88
	2	11.2	1.01	13.3	1.09	15.8	1.25	15.4	1.42	19.5	1.51	20.6	1.71	23.5	1.92
	4	11.2	1.03	13.3	1.11	15.8	1.27	15.4	1.45	19.5	1.53	20.6	1.74	23.5	1.95
	6	11.2	1.04	13.3	1.13	15.8	1.29	15.4	1.49	19.5	1.56	20.6	1.77	23.5	1.99
	8	11.2	1.06	13.3	1.15	15.8	1.32	15.4	1.51	19.5	1.59	20.6	1.80	23.5	2.02
	10	11.2	1.07	13.3	1.16	15.8	1.33	15.4	1.54	19.5	1.61	20.6	1.82	23.5	2.05
	12	11.2	1.08	13.3	1.18	15.8	1.36	15.4	1.56	19.5	1.64	20.6	1.86	23.5	2.09
	14	11.2	1.10	13.3	1.20	15.8	1.39	15.4	1.58	19.5	1.69	20.6	1.96	23.5	2.24
	16	11.2	1.12	13.3	1.26	15.8	1.47	15.4	1.61	19.5	1.80	20.6	2.09	23.5	2.40
	18	11.2	1.18	13.3	1.33	15.8	1.57	15.4	1.66	19.5	1.92	20.6	2.23	23.5	2.56
	20	11.2	1.25	13.3	1.20	15.8	1.67	15.4	1.74	19.5	2.05	20.6	2.37	23.5	2.58
	21	11.2	1.33	13.3	1.42	15.8	1.79	15.4	1.78	19.5	2.18	20.6	2.48	23.5	2.72
	23	11.2	1.41	13.3	1.60	15.8	1.90	15.4	1.85	19.5	2.31	20.6	2.55	23.5	2.80
	25	11.2	1.48	13.3	1.70	15.8	2.02	15.4	1.92	19.5	2.46	20.6	2.58	23.5	2.92
	27	11.2	1.57	13.3	1.80	15.8	2.14	15.4	2.06	19.5	2.61	20.6	2.66	23.5	3.02
	29	11.2	1.63	13.3	1.89	15.8	2.23	15.4	2.09	19.5	2.73	20.6	2.80	23.5	3.03
	31	11.2	1.74	13.3	2.03	15.8	2.31	15.4	2.16	19.5	2.80	20.6	2.86	23.5	3.17
	33	11.2	1.79	13.3	2.08	15.8	2.48	15.4	2.22	19.5	2.92	20.6	2.99	23.5	3.24
	35	11.2	1.84	13.3	2.16	15.8	2.65	15.4	2.22	19.5	3.08	20.6	3.06	23.5	3.31
	37	11.2	1.99	13.3	2.37	15.8	2.80	15.4	2.34	19.5	3.18	20.6	3.10	23.5	3.44
	39	11.2	2.18	13.3	2.62	15.8	2.95	15.4	2.40	19.5	3.44	20.6	3.24	23.5	3.52
	41	11.2	2.46	13.3	2.69	15.8	2.96	15.4	2.49	19.5	3.47	20.6	3.29	23.5	3.64
43	11.2	2.59	13.3	2.76	15.8	3.03	15.4	2.56	19.5	3.54	20.6	3.40	23.5	3.74	
45	11.2	2.66	13.3	2.86	15.8	3.11	15.4	2.63	19.5	3.68	20.6	3.51	23.5	3.89	
48	11.2	2.24	13.3	2.28	15.8	2.51	15.4	2.67	19.5	2.37	20.6	2.18	23.5	2.72	
50	11.2	2.15	13.3	2.15	15.8	2.36	15.4	2.73	19.5	2.03	20.6	1.82	23.5	2.43	
52	11.2	1.97	13.3	1.91	15.8	2.09	15.4	2.79	19.5	1.44	20.6	1.21	23.5	1.92	
54	11.2	1.80	13.3	1.68	15.8	1.83	15.4	2.84	19.5	0.85	20.6	0.60	23.5	1.41	

Обозначения:

ТС: Полная производительность (кВт)

PI: Потребляемая мощность (компрессор + двигатель вентилятора наружного блока) (кВт)

Продолжение таблицы
на следующей странице...

MVS FDC II-S

Таблица 2-8.21: Частичная холодильная нагрузка для блоков производительностью 24 л.с.

Частичная нагрузка	Температура наружного воздуха (°CDB)	Температура в помещении (°C DB/WD)													
		20.8/14		23.3/16		25.8/18		27/19		28.2/20		30.7/22		32/24	
		ТС	PI	ТС	PI	ТС	PI	ТС	PI	ТС	PI	ТС	PI	ТС	PI
		кВт	кВт	кВт	кВт	кВт	кВт	кВт	кВт	кВт	кВт	кВт	кВт	кВт	кВт
100%	-5	47.0	7.74	55.2	8.43	66.1	9.29	67.0	10.91	72.6	10.65	83.5	11.80	86.0	13.01
	-2	47.0	7.84	55.2	8.54	66.1	9.48	67.0	11.00	72.6	10.81	83.5	11.95	86.0	13.10
	0	47.0	7.93	55.2	8.64	66.1	9.64	67.0	11.16	72.6	10.91	83.5	12.17	86.0	13.25
	2	47.0	8.05	55.2	8.75	66.1	9.86	67.0	11.26	72.6	11.04	83.5	12.36	86.0	13.46
	4	47.0	8.13	55.2	8.90	66.1	9.99	67.0	11.43	72.6	11.19	83.5	12.49	86.0	13.61
	6	47.0	8.30	55.2	9.03	66.1	10.16	67.0	11.67	72.6	11.37	83.5	12.69	86.0	13.83
	8	47.0	8.43	55.2	9.22	66.1	10.35	67.0	11.88	72.6	11.56	83.5	12.90	86.0	14.07
	10	47.0	8.60	55.2	9.39	66.1	10.51	67.0	12.07	72.6	11.79	83.5	13.13	86.0	14.28
	12	47.0	8.77	55.2	9.59	66.1	10.91	67.0	12.31	72.6	12.02	83.5	13.39	84.8	14.39
	14	47.0	8.95	55.2	9.80	66.1	11.42	67.0	13.09	72.6	12.25	83.5	13.68	83.9	14.57
	16	47.0	9.12	55.2	10.03	66.1	11.70	67.0	13.42	72.6	12.52	81.0	13.86	82.7	14.74
	18	47.0	9.29	55.2	10.24	66.1	12.14	67.0	13.95	72.6	12.78	80.1	14.36	81.7	15.12
	20	47.0	9.50	55.2	10.59	66.1	13.16	67.0	14.90	72.6	13.74	78.9	15.08	80.5	15.88
	21	47.0	9.59	55.2	11.02	66.1	14.09	67.0	15.81	72.6	14.23	78.4	15.46	80.1	16.26
	23	47.0	10.26	55.2	11.90	66.1	15.16	67.0	16.90	72.6	15.31	77.4	16.22	78.9	17.01
	25	47.0	10.98	55.2	12.83	66.1	16.36	67.0	17.74	72.6	16.45	76.2	16.98	77.9	17.77
	27	47.0	11.74	55.2	13.79	66.1	17.32	67.0	18.81	72.6	17.64	75.0	17.73	76.7	18.56
	29	47.0	12.56	55.2	14.81	66.1	18.62	67.0	19.36	72.4	18.78	74.1	19.17	75.8	19.31
	31	47.0	13.43	55.2	15.89	66.1	19.91	67.0	19.72	71.4	19.54	72.9	19.86	74.6	20.10
	33	47.0	14.33	55.2	17.02	66.1	20.86	67.0	20.28	70.3	20.29	71.9	20.59	73.6	20.89
	35	47.0	15.27	55.2	18.25	66.1	21.29	67.0	21.61	69.1	21.64	70.7	21.86	72.4	22.08
	37	47.0	16.29	55.2	19.53	66.1	21.44	66.1	22.59	68.4	22.92	69.8	23.20	71.2	23.51
	39	47.0	17.33	55.2	20.87	66.1	21.83	65.3	23.47	67.4	23.87	68.6	24.34	70.3	24.54
	41	47.0	17.98	55.2	21.68	66.1	22.15	64.5	24.31	66.5	24.81	66.1	25.05	69.3	25.31
43	47.0	18.63	55.2	22.10	66.1	22.89	64.2	25.47	65.6	25.87	66.5	26.31	66.7	26.52	
45	47.0	19.49	55.2	22.72	66.1	24.33	63.8	27.08	64.6	28.58	65.9	30.02	65.6	30.59	
48	47.0	22.48	55.2	24.21	66.1	25.93	63.1	29.18	63.7	30.90	64.4	32.63	64.7	34.36	
50	47.0	25.46	55.2	27.19	66.1	28.92	62.5	30.65	62.8	32.37	63.4	34.10	63.7	35.83	
52	47.0	28.44	55.2	30.17	66.1	31.90	61.9	33.63	61.8	35.36	62.4	37.08	62.7	38.81	
54	47.0	31.42	55.2	33.15	66.1	34.88	61.4	36.61	60.9	38.34	61.4	40.07	61.7	41.80	
75%	-5	34.0	4.54	40.7	4.69	47.1	5.45	50.5	6.29	54.8	6.77	62.3	7.78	66.9	8.91
	-2	34.0	4.60	40.7	4.74	47.1	5.53	50.5	6.32	54.8	6.85	62.3	7.86	66.9	9.00
	0	34.0	4.65	40.7	4.80	47.1	5.61	50.5	6.35	54.8	6.94	62.3	7.95	66.9	9.07
	2	34.0	4.72	40.7	4.87	47.1	5.68	50.5	6.53	54.8	7.05	62.3	8.11	66.9	9.20
	4	34.0	4.76	40.7	4.94	47.1	5.78	50.5	6.63	54.8	7.13	62.3	8.24	66.9	9.33
	6	34.0	4.87	40.7	5.04	47.1	5.89	50.5	6.76	54.8	7.26	62.3	8.36	66.9	9.49
	8	34.0	4.94	40.7	5.14	47.1	6.02	50.5	6.87	54.8	7.39	62.3	8.52	66.9	9.58
	10	34.0	5.04	40.7	5.26	47.1	6.14	50.5	6.99	54.8	7.56	62.3	8.63	66.9	9.73
	12	34.0	5.14	40.7	5.36	47.1	6.26	50.5	7.12	54.8	7.70	62.3	8.79	66.9	9.91
	14	34.0	5.25	40.7	5.46	47.1	6.38	50.5	7.35	54.8	7.84	62.3	8.95	66.9	10.09
	16	34.0	5.35	40.7	5.56	47.1	6.52	50.5	7.38	54.8	7.99	62.3	9.13	66.9	10.27
	18	34.0	5.45	40.7	5.68	47.1	6.64	50.5	7.40	54.8	8.15	62.3	9.31	66.9	10.59
	20	34.0	5.57	40.7	5.82	47.1	6.78	50.5	7.88	54.8	8.45	62.3	10.01	66.9	11.09
	21	34.0	5.62	40.7	5.86	47.1	6.89	50.5	8.44	54.8	8.76	62.3	10.37	66.9	11.35
	23	34.0	6.01	40.7	6.10	47.1	7.41	50.5	8.90	54.8	9.39	62.3	11.13	66.9	11.87
	25	34.0	6.44	40.7	6.54	47.1	7.95	50.5	9.55	54.8	10.03	62.3	11.91	66.9	12.39
	27	34.0	6.88	40.7	6.98	47.1	8.51	50.5	10.24	54.8	10.73	62.3	12.75	66.9	12.91
	29	34.0	7.36	40.7	7.46	47.1	9.11	50.5	10.71	54.8	11.47	62.3	13.33	66.9	13.43
	31	34.0	7.88	40.7	7.96	47.1	9.73	50.5	11.43	54.8	12.23	62.3	13.85	66.9	13.97
	33	34.0	8.41	40.7	8.48	47.1	10.41	50.5	12.12	54.8	13.05	62.3	14.39	66.9	14.49
	35	34.0	8.95	40.7	9.04	47.1	11.11	50.5	12.67	54.8	13.91	62.3	14.91	66.9	15.03
	37	34.0	9.55	40.7	9.62	47.1	11.85	50.5	13.25	54.8	14.83	62.3	15.43	66.9	15.55
	39	34.0	10.16	40.7	10.26	47.1	12.63	50.5	13.76	54.8	15.82	62.3	15.97	66.9	16.09
	41	34.0	10.54	40.7	10.74	47.1	13.11	50.5	14.26	54.8	15.89	62.3	16.38	66.9	16.47
43	34.0	10.92	40.7	11.21	47.1	13.58	50.5	14.93	54.8	16.22	62.3	16.59	66.9	16.73	
45	34.0	11.43	40.7	11.78	47.1	14.15	50.5	15.88	54.8	16.67	62.3	18.03	66.9	18.80	
48	34.0	13.18	40.7	14.45	47.1	15.71	50.5	16.98	54.8	18.25	62.3	19.52	66.9	20.78	
50	34.0	14.93	40.7	16.20	47.1	17.46	50.5	18.73	54.8	20.00	62.3	21.27	66.9	22.53	
52	34.0	16.68	40.7	17.94	47.1	19.21	50.5	20.48	54.8	21.75	62.3	23.01	66.9	24.28	
54	34.0	18.43	40.7	19.69	47.1	20.96	50.5	22.23	54.8	23.50	62.3	24.76	66.9	26.03	

Обозначения:

ТС: Полная производительность (кВт)

PI: Потребляемая мощность (компрессор + двигатель вентилятора наружного блока) (кВт)

Продолжение таблицы на следующей странице...

Таблица 2-8.21: Частичная холодильная нагрузка для блоков производительностью 24 л.с. (продолжение)

Частичная нагрузка	Температура наружного воздуха (°CDB)	Температура в помещении (°C DB/WD)													
		20.8/14		23.3/16		25.8/18		27/19		28.2/20		30.7/22		32/24	
		ТС кВт	PI кВт	ТС кВт	PI кВт	ТС кВт	PI кВт	ТС кВт	PI кВт	ТС кВт	PI кВт	ТС кВт	PI кВт	ТС кВт	PI кВт
50%	-5	22.8	2.54	27.2	2.77	31.6	3.05	33.8	3.90	36.7	4.26	41.8	4.73	44.9	5.43
	-2	22.8	2.58	27.2	2.80	31.6	3.09	33.8	3.96	36.7	4.33	41.8	4.80	44.9	5.46
	0	22.8	2.60	27.2	2.84	31.6	3.14	33.8	4.01	36.7	4.39	41.8	4.88	44.9	5.54
	2	22.8	2.64	27.2	2.87	31.6	3.18	33.8	4.09	36.7	4.45	41.8	4.97	44.9	5.61
	4	22.8	2.67	27.2	2.92	31.6	3.24	33.8	4.14	36.7	4.54	41.8	5.05	44.9	5.69
	6	22.8	2.73	27.2	2.97	31.6	3.30	33.8	4.23	36.7	4.63	41.8	5.15	44.9	5.82
	8	22.8	2.77	27.2	3.03	31.6	3.37	33.8	4.31	36.7	4.72	41.8	5.25	44.9	5.91
	10	22.8	2.82	27.2	3.08	31.6	3.44	33.8	4.43	36.7	4.80	41.8	5.35	44.9	5.90
	12	22.8	2.88	27.2	3.15	31.6	3.50	33.8	4.51	36.7	4.90	41.8	5.45	44.9	6.00
	14	22.8	2.94	27.2	3.22	31.6	3.57	33.8	4.59	36.7	4.98	41.8	5.55	44.9	6.10
	16	22.8	2.99	27.2	3.30	31.6	3.65	33.8	4.67	36.7	5.08	41.8	5.65	44.9	6.21
	18	22.8	3.05	27.2	3.36	31.6	3.72	33.8	4.74	36.7	5.18	41.8	5.74	44.9	6.33
	20	22.8	3.12	27.2	3.48	31.6	3.79	33.8	4.84	36.7	5.21	41.8	5.86	44.9	6.45
	21	22.8	3.15	27.2	3.62	31.6	3.86	33.8	5.19	36.7	5.31	41.8	5.92	44.9	6.59
	23	22.8	3.37	27.2	3.91	31.6	4.15	33.8	5.55	36.7	5.65	41.8	6.16	44.9	6.65
	25	22.8	3.61	27.2	4.21	31.6	4.45	33.8	5.85	36.7	6.02	41.8	6.57	44.9	7.08
	27	22.8	3.86	27.2	4.53	31.6	4.77	33.8	6.14	36.7	6.41	41.8	7.00	44.9	7.55
	29	22.8	4.12	27.2	4.86	31.6	5.10	33.8	6.40	36.7	6.82	41.8	7.47	44.9	8.06
	31	22.8	4.41	27.2	5.22	31.6	5.45	33.8	6.75	36.7	7.25	41.8	7.94	44.9	8.61
	33	22.8	4.71	27.2	5.59	31.6	5.83	33.8	7.04	36.7	7.70	41.8	8.45	44.9	9.15
35	22.8	5.01	27.2	5.99	31.6	6.22	33.8	7.10	36.7	8.17	41.8	9.00	44.9	9.76	
37	22.8	5.35	27.2	6.41	31.6	6.64	33.8	7.42	36.7	8.68	41.8	9.57	44.9	10.39	
39	22.8	5.69	27.2	6.85	31.6	7.07	33.8	7.71	36.7	9.00	41.8	10.15	44.9	11.06	
41	22.8	5.91	27.2	7.12	31.6	7.34	33.8	7.98	36.7	9.32	41.8	10.63	44.9	11.76	
43	22.8	6.12	27.2	7.26	31.6	7.61	33.8	8.36	36.7	9.78	41.8	11.09	44.9	12.30	
45	22.8	6.61	27.2	8.17	31.6	8.64	33.8	9.11	36.7	10.57	41.8	11.58	44.9	12.83	
48	22.8	7.59	27.2	8.52	31.6	9.44	33.8	10.36	36.7	11.28	41.8	12.21	44.9	13.13	
50	22.8	8.57	27.2	9.50	31.6	10.42	33.8	11.34	36.7	12.26	41.8	13.19	44.9	14.11	
52	22.8	9.55	27.2	10.48	31.6	11.40	33.8	12.32	36.7	13.24	41.8	14.17	44.9	15.09	
54	22.8	10.53	27.2	11.45	31.6	12.38	33.8	13.30	36.7	14.22	41.8	15.15	44.9	16.07	
25%	-5	11.4	1.38	13.6	1.50	15.8	1.66	16.9	2.27	18.3	2.36	20.8	2.68	22.4	2.89
	-2	11.4	1.40	13.6	1.52	15.8	1.68	16.9	2.33	18.3	2.40	20.8	2.72	22.4	2.93
	0	11.4	1.41	13.6	1.54	15.8	1.71	16.9	2.34	18.3	2.43	20.8	2.76	22.4	2.98
	2	11.4	1.44	13.6	1.56	15.8	1.73	16.9	2.35	18.3	2.47	20.8	2.78	22.4	3.04
	4	11.4	1.45	13.6	1.59	15.8	1.76	16.9	2.35	18.3	2.52	20.8	2.85	22.4	3.12
	6	11.4	1.48	13.6	1.61	15.8	1.79	16.9	2.37	18.3	2.57	20.8	2.89	22.4	3.21
	8	11.4	1.50	13.6	1.65	15.8	1.83	16.9	2.38	18.3	2.60	20.8	2.93	22.4	3.31
	10	11.4	1.53	13.6	1.68	15.8	1.87	16.9	2.36	18.3	2.68	20.8	3.01	22.4	3.36
	12	11.4	1.56	13.6	1.71	15.8	1.90	16.9	2.37	18.3	2.73	20.8	3.07	22.4	3.41
	14	11.4	1.60	13.6	1.75	15.8	1.94	16.9	2.39	18.3	2.77	20.8	3.12	22.4	3.48
	16	11.4	1.63	13.6	1.79	15.8	1.98	16.9	2.39	18.3	2.81	20.8	3.17	22.4	3.53
	18	11.4	1.66	13.6	1.83	15.8	2.02	16.9	2.40	18.3	2.86	20.8	3.23	22.4	3.60
	20	11.4	1.69	13.6	1.89	15.8	2.06	16.9	2.51	18.3	2.92	20.8	3.28	22.4	3.67
	21	11.4	1.71	13.6	1.97	15.8	2.10	16.9	2.64	18.3	2.95	20.8	3.32	22.4	3.71
	23	11.4	1.83	13.6	2.12	15.8	2.26	16.9	2.82	18.3	3.00	20.8	3.37	22.4	3.79
	25	11.4	1.96	13.6	2.29	15.8	2.42	16.9	3.00	18.3	3.09	20.8	3.55	22.4	4.04
	27	11.4	2.09	13.6	2.46	15.8	2.59	16.9	3.24	18.3	3.28	20.8	3.78	22.4	4.31
	29	11.4	2.24	13.6	2.64	15.8	2.77	16.9	3.33	18.3	3.49	20.8	4.02	22.4	4.59
	31	11.4	2.40	13.6	2.83	15.8	2.96	16.9	3.55	18.3	3.71	20.8	4.27	22.4	4.89
	33	11.4	2.56	13.6	3.04	15.8	3.17	16.9	3.75	18.3	3.94	20.8	4.54	22.4	5.19
35	11.4	2.72	13.6	3.25	15.8	3.38	16.9	3.86	18.3	4.16	20.8	4.82	22.4	5.52	
37	11.4	2.91	13.6	3.48	15.8	3.61	16.9	4.03	18.3	4.42	20.8	5.11	22.4	5.86	
39	11.4	3.09	13.6	3.72	15.8	3.84	16.9	4.19	18.3	4.69	20.8	5.42	22.4	6.22	
41	11.4	3.21	13.6	3.87	15.8	3.99	16.9	4.34	18.3	4.89	20.8	5.71	22.4	6.51	
43	11.4	3.32	13.6	3.94	15.8	4.13	16.9	4.62	18.3	5.01	20.8	6.00	22.4	6.80	
45	11.4	3.48	13.6	4.44	15.8	4.73	16.9	5.10	18.3	5.60	20.8	6.58	22.4	7.09	
48	11.4	4.09	13.6	4.67	15.8	5.24	16.9	5.82	18.3	6.40	20.8	6.98	22.4	7.56	
50	11.4	4.70	13.6	5.27	15.8	5.85	16.9	6.43	18.3	7.01	20.8	7.59	22.4	8.17	
52	11.4	5.31	13.6	5.88	15.8	6.46	16.9	7.04	18.3	7.62	20.8	8.20	22.4	8.77	
54	11.4	5.91	13.6	6.49	15.8	7.07	16.9	7.65	18.3	8.23	20.8	8.81	22.4	9.38	

Обозначения:

ТС: Полная производительность (кВт)

PI: Потребляемая мощность (компрессор + двигатель вентилятора наружного блока) (кВт)

MVS FDC II-S

Таблица 2-8.22: Частичная холодильная нагрузка для блоков производительностью 26 л.с.

Частичная нагрузка	Температура наружного воздуха (°CDB)	Температура в помещении (°C DB/WD)													
		20.8/14		23.3/16		25.8/18		27/19		28.2/20		30.7/22		32/24	
		ТС	PI	ТС	PI	ТС	PI	ТС	PI	ТС	PI	ТС	PI	ТС	PI
		кВт	кВт	кВт	кВт	кВт	кВт	кВт	кВт	кВт	кВт	кВт	кВт	кВт	кВт
100%	-5	51.2	7.69	60.1	8.37	72.0	9.23	73.0	10.84	79.2	10.58	91.0	11.72	93.8	12.92
	-2	51.2	7.79	60.1	8.48	72.0	9.42	73.0	10.92	79.2	10.74	91.0	11.87	93.8	13.01
	0	51.2	7.88	60.1	8.59	72.0	9.58	73.0	11.09	79.2	10.84	91.0	12.09	93.8	13.16
	2	51.2	7.99	60.1	8.70	72.0	9.79	73.0	11.19	79.2	10.97	91.0	12.28	93.8	13.38
	4	51.2	8.07	60.1	8.85	72.0	9.92	73.0	11.36	79.2	11.12	91.0	12.41	93.8	13.53
	6	51.2	8.24	60.1	8.97	72.0	10.09	73.0	11.60	79.2	11.29	91.0	12.60	93.8	13.74
	8	51.2	8.37	60.1	9.16	72.0	10.28	73.0	11.81	79.2	11.49	91.0	12.82	93.8	13.98
	10	51.2	8.54	60.1	9.33	72.0	10.44	73.0	11.99	79.2	11.71	91.0	13.05	93.8	14.18
	12	51.2	8.71	60.1	9.53	72.0	10.84	73.0	12.23	79.2	11.94	91.0	13.31	92.4	14.30
	14	51.2	8.89	60.1	9.74	72.0	11.34	73.0	13.01	79.2	12.17	91.0	13.59	91.4	14.48
	16	51.2	9.06	60.1	9.97	72.0	11.62	73.0	13.34	79.2	12.44	88.3	13.77	90.1	14.65
	18	51.2	9.23	60.1	10.17	72.0	12.06	73.0	13.86	79.2	12.70	87.2	14.26	89.1	15.02
	20	51.2	9.44	60.1	10.52	72.0	13.07	73.0	14.80	79.2	13.65	85.9	14.99	87.8	15.77
	21	51.2	9.52	60.1	10.95	72.0	14.00	73.0	15.71	79.2	14.14	85.4	15.36	87.2	16.15
	23	51.2	10.19	60.1	11.82	72.0	15.06	73.0	16.79	79.2	15.21	84.4	16.11	85.9	16.90
	25	51.2	10.91	60.1	12.74	72.0	16.25	73.0	17.63	79.2	16.34	83.1	16.87	84.9	17.65
	27	51.2	11.66	60.1	13.70	72.0	17.21	73.0	18.69	79.2	17.53	81.8	17.62	83.6	18.44
	29	51.2	12.48	60.1	14.71	72.0	18.50	73.0	19.24	78.9	18.66	80.7	19.04	82.5	19.19
	31	51.2	13.34	60.1	15.78	72.0	19.78	73.0	19.59	77.8	19.41	79.4	19.73	81.2	19.97
	33	51.2	14.24	60.1	16.91	72.0	20.73	73.0	20.15	76.5	20.16	78.4	20.45	80.2	20.75
	35	51.2	15.17	60.1	18.13	72.0	21.15	73.0	21.47	75.2	21.50	77.1	21.72	78.9	21.93
	37	51.2	16.18	60.1	19.40	72.0	21.30	72.1	22.45	74.5	22.77	76.0	23.05	77.6	23.36
	39	51.2	17.22	60.1	20.73	72.0	21.69	71.1	23.32	73.5	23.71	74.7	24.19	76.5	24.38
	41	51.2	17.87	60.1	21.54	72.0	22.01	70.2	24.16	72.5	24.65	72.0	24.88	75.5	25.15
43	51.2	18.51	60.1	21.96	72.0	22.74	70.0	25.30	71.4	25.71	72.4	26.14	72.7	26.34	
45	51.2	19.37	60.1	22.57	72.0	24.17	69.5	26.91	70.4	28.40	71.8	29.82	71.5	30.40	
48	51.2	22.33	60.1	24.05	72.0	25.77	68.7	28.99	69.4	30.70	70.2	32.42	70.5	34.14	
50	51.2	25.29	60.1	27.01	72.0	28.73	68.1	30.45	68.4	32.16	69.1	33.88	69.4	35.60	
52	51.2	28.26	60.1	29.97	72.0	31.69	67.5	33.41	67.4	35.13	68.0	36.84	68.3	38.56	
54	51.2	31.22	60.1	32.94	72.0	34.65	66.9	36.37	66.4	38.09	66.9	39.81	67.3	41.53	
75%	-5	37.0	4.51	44.3	4.66	51.3	5.41	55.0	6.25	59.7	6.72	67.8	7.73	72.9	8.85
	-2	37.0	4.57	44.3	4.71	51.3	5.49	55.0	6.28	59.7	6.80	67.8	7.81	72.9	8.94
	0	37.0	4.62	44.3	4.77	51.3	5.58	55.0	6.31	59.7	6.89	67.8	7.89	72.9	9.01
	2	37.0	4.69	44.3	4.83	51.3	5.64	55.0	6.49	59.7	7.00	67.8	8.06	72.9	9.14
	4	37.0	4.73	44.3	4.91	51.3	5.74	55.0	6.59	59.7	7.09	67.8	8.18	72.9	9.27
	6	37.0	4.83	44.3	5.01	51.3	5.85	55.0	6.71	59.7	7.21	67.8	8.31	72.9	9.43
	8	37.0	4.91	44.3	5.11	51.3	5.98	55.0	6.83	59.7	7.34	67.8	8.46	72.9	9.52
	10	37.0	5.01	44.3	5.23	51.3	6.10	55.0	6.95	59.7	7.51	67.8	8.57	72.9	9.67
	12	37.0	5.11	44.3	5.33	51.3	6.22	55.0	7.07	59.7	7.65	67.8	8.74	72.9	9.85
	14	37.0	5.21	44.3	5.43	51.3	6.33	55.0	7.30	59.7	7.78	67.8	8.90	72.9	10.03
	16	37.0	5.31	44.3	5.53	51.3	6.47	55.0	7.33	59.7	7.94	67.8	9.07	72.9	10.21
	18	37.0	5.41	44.3	5.65	51.3	6.59	55.0	7.35	59.7	8.10	67.8	9.25	72.9	10.53
	20	37.0	5.53	44.3	5.78	51.3	6.73	55.0	7.83	59.7	8.40	67.8	9.95	72.9	11.02
	21	37.0	5.58	44.3	5.82	51.3	6.85	55.0	8.38	59.7	8.70	67.8	10.31	72.9	11.28
	23	37.0	5.98	44.3	6.06	51.3	7.37	55.0	8.84	59.7	9.33	67.8	11.06	72.9	11.80
	25	37.0	6.40	44.3	6.50	51.3	7.90	55.0	9.49	59.7	9.97	67.8	11.84	72.9	12.31
	27	37.0	6.84	44.3	6.94	51.3	8.46	55.0	10.17	59.7	10.66	67.8	12.67	72.9	12.83
	29	37.0	7.32	44.3	7.41	51.3	9.05	55.0	10.64	59.7	11.40	67.8	13.25	72.9	13.34
	31	37.0	7.82	44.3	7.91	51.3	9.67	55.0	11.35	59.7	12.15	67.8	13.76	72.9	13.88
	33	37.0	8.35	44.3	8.43	51.3	10.35	55.0	12.04	59.7	12.97	67.8	14.30	72.9	14.40
	35	37.0	8.89	44.3	8.98	51.3	11.04	55.0	12.59	59.7	13.82	67.8	14.81	72.9	14.93
	37	37.0	9.49	44.3	9.56	51.3	11.78	55.0	13.16	59.7	14.73	67.8	15.33	72.9	15.45
	39	37.0	10.10	44.3	10.19	51.3	12.55	55.0	13.67	59.7	15.71	67.8	15.87	72.9	15.99
	41	37.0	10.48	44.3	10.67	51.3	13.02	55.0	14.17	59.7	15.78	67.8	16.27	72.9	16.36
43	37.0	10.85	44.3	11.14	51.3	13.49	55.0	14.84	59.7	16.12	67.8	16.48	72.9	16.62	
45	37.0	11.36	44.3	11.70	51.3	14.06	55.0	15.78	59.7	16.57	67.8	17.91	72.9	18.68	
48	37.0	13.09	44.3	14.35	51.3	15.61	55.0	16.87	59.7	18.13	67.8	19.39	72.9	20.65	
50	37.0	14.83	44.3	16.09	51.3	17.35	55.0	18.61	59.7	19.87	67.8	21.13	72.9	22.39	
52	37.0	16.57	44.3	17.83	51.3	19.09	55.0	20.35	59.7	21.61	67.8	22.86	72.9	24.12	
54	37.0	18.31	44.3	19.57	51.3	20.83	55.0	22.08	59.7	23.34	67.8	24.60	72.9	25.86	

Обозначения:

ТС: Полная производительность (кВт)

PI: Потребляемая мощность (компрессор + двигатель вентилятора наружного блока) (кВт)

Продолжение таблицы на следующей странице...

Таблица 2-8.22: Частичная холодильная нагрузка для блоков производительностью 26 л.с. (продолжение)

Частичная нагрузка	Температура наружного воздуха (°CDB)	Температура в помещении (°C DB/WD)													
		20.8/14		23.3/16		25.8/18		27/19		28.2/20		30.7/22		32/24	
		ТС	PI	ТС	PI	ТС	PI	ТС	PI	ТС	PI	ТС	PI	ТС	PI
		кВт	кВт	кВт	кВт	кВт	кВт	кВт	кВт	кВт	кВт	кВт	кВт	кВт	кВт
50%	-5	24.8	2.52	29.6	2.75	34.5	3.03	36.9	3.88	40.0	4.23	45.6	4.70	48.9	5.39
	-2	24.8	2.56	29.6	2.79	34.5	3.07	36.9	3.93	40.0	4.30	45.6	4.77	48.9	5.43
	0	24.8	2.59	29.6	2.82	34.5	3.12	36.9	3.98	40.0	4.36	45.6	4.84	48.9	5.50
	2	24.8	2.62	29.6	2.86	34.5	3.16	36.9	4.06	40.0	4.42	45.6	4.94	48.9	5.57
	4	24.8	2.65	29.6	2.90	34.5	3.22	36.9	4.11	40.0	4.51	45.6	5.02	48.9	5.65
	6	24.8	2.71	29.6	2.95	34.5	3.28	36.9	4.20	40.0	4.60	45.6	5.12	48.9	5.78
	8	24.8	2.75	29.6	3.01	34.5	3.35	36.9	4.28	40.0	4.69	45.6	5.22	48.9	5.87
	10	24.8	2.80	29.6	3.06	34.5	3.41	36.9	4.40	40.0	4.77	45.6	5.32	48.9	5.86
	12	24.8	2.86	29.6	3.13	34.5	3.48	36.9	4.48	40.0	4.87	45.6	5.41	48.9	5.96
	14	24.8	2.92	29.6	3.20	34.5	3.55	36.9	4.56	40.0	4.95	45.6	5.51	48.9	6.06
	16	24.8	2.98	29.6	3.27	34.5	3.63	36.9	4.64	40.0	5.04	45.6	5.61	48.9	6.17
	18	24.8	3.03	29.6	3.34	34.5	3.69	36.9	4.71	40.0	5.14	45.6	5.71	48.9	6.29
	20	24.8	3.10	29.6	3.45	34.5	3.77	36.9	4.81	40.0	5.18	45.6	5.82	48.9	6.41
	21	24.8	3.13	29.6	3.60	34.5	3.84	36.9	5.16	40.0	5.28	45.6	5.88	48.9	6.54
	23	24.8	3.35	29.6	3.88	34.5	4.13	36.9	5.51	40.0	5.61	45.6	6.12	48.9	6.60
	25	24.8	3.58	29.6	4.19	34.5	4.43	36.9	5.81	40.0	5.98	45.6	6.52	48.9	7.03
	27	24.8	3.83	29.6	4.50	34.5	4.74	36.9	6.10	40.0	6.37	45.6	6.95	48.9	7.50
	29	24.8	4.10	29.6	4.83	34.5	5.07	36.9	6.36	40.0	6.78	45.6	7.42	48.9	8.00
	31	24.8	4.38	29.6	5.18	34.5	5.42	36.9	6.71	40.0	7.21	45.6	7.89	48.9	8.55
	33	24.8	4.68	29.6	5.55	34.5	5.79	36.9	6.99	40.0	7.65	45.6	8.39	48.9	9.10
	35	24.8	4.98	29.6	5.95	34.5	6.18	36.9	7.05	40.0	8.12	45.6	8.94	48.9	9.70
	37	24.8	5.31	29.6	6.37	34.5	6.59	36.9	7.37	40.0	8.63	45.6	9.51	48.9	10.32
	39	24.8	5.66	29.6	6.81	34.5	7.03	36.9	7.66	40.0	8.95	45.6	10.09	48.9	10.99
	41	24.8	5.87	29.6	7.07	34.5	7.29	36.9	7.93	40.0	9.26	45.6	10.56	48.9	11.69
43	24.8	6.08	29.6	7.21	34.5	7.56	36.9	8.31	40.0	9.72	45.6	11.01	48.9	12.22	
45	24.8	6.57	29.6	8.12	34.5	8.58	36.9	9.05	40.0	10.50	45.6	11.51	48.9	12.74	
48	24.8	7.55	29.6	8.46	34.5	9.38	36.9	10.29	40.0	11.21	45.6	12.13	48.9	13.04	
50	24.8	8.52	29.6	9.43	34.5	10.35	36.9	11.27	40.0	12.18	45.6	13.10	48.9	14.02	
52	24.8	9.49	29.6	10.41	34.5	11.32	36.9	12.24	40.0	13.16	45.6	14.07	48.9	14.99	
54	24.8	10.46	29.6	11.38	34.5	12.30	36.9	13.21	40.0	14.13	45.6	15.05	48.9	15.96	
25%	-5	12.4	1.37	14.8	1.49	17.2	1.65	18.4	2.26	19.9	2.34	22.6	2.67	24.4	2.87
	-2	12.4	1.39	14.8	1.51	17.2	1.67	18.4	2.32	19.9	2.39	22.6	2.70	24.4	2.91
	0	12.4	1.41	14.8	1.53	17.2	1.70	18.4	2.32	19.9	2.41	22.6	2.75	24.4	2.96
	2	12.4	1.43	14.8	1.55	17.2	1.72	18.4	2.33	19.9	2.46	22.6	2.76	24.4	3.02
	4	12.4	1.44	14.8	1.58	17.2	1.75	18.4	2.34	19.9	2.50	22.6	2.83	24.4	3.10
	6	12.4	1.47	14.8	1.60	17.2	1.78	18.4	2.36	19.9	2.55	22.6	2.87	24.4	3.19
	8	12.4	1.49	14.8	1.63	17.2	1.82	18.4	2.37	19.9	2.59	22.6	2.92	24.4	3.29
	10	12.4	1.52	14.8	1.66	17.2	1.85	18.4	2.34	19.9	2.66	22.6	2.99	24.4	3.34
	12	12.4	1.55	14.8	1.70	17.2	1.89	18.4	2.36	19.9	2.71	22.6	3.05	24.4	3.39
	14	12.4	1.59	14.8	1.74	17.2	1.93	18.4	2.37	19.9	2.75	22.6	3.10	24.4	3.46
	16	12.4	1.62	14.8	1.78	17.2	1.97	18.4	2.38	19.9	2.79	22.6	3.15	24.4	3.51
	18	12.4	1.65	14.8	1.81	17.2	2.01	18.4	2.39	19.9	2.85	22.6	3.21	24.4	3.58
	20	12.4	1.68	14.8	1.88	17.2	2.05	18.4	2.50	19.9	2.90	22.6	3.26	24.4	3.64
	21	12.4	1.70	14.8	1.95	17.2	2.08	18.4	2.63	19.9	2.93	22.6	3.30	24.4	3.68
	23	12.4	1.82	14.8	2.11	17.2	2.24	18.4	2.80	19.9	2.98	22.6	3.35	24.4	3.76
	25	12.4	1.95	14.8	2.27	17.2	2.40	18.4	2.98	19.9	3.07	22.6	3.52	24.4	4.02
	27	12.4	2.08	14.8	2.44	17.2	2.57	18.4	3.22	19.9	3.26	22.6	3.75	24.4	4.28
	29	12.4	2.23	14.8	2.62	17.2	2.75	18.4	3.31	19.9	3.47	22.6	3.99	24.4	4.56
	31	12.4	2.38	14.8	2.82	17.2	2.94	18.4	3.53	19.9	3.68	22.6	4.24	24.4	4.85
	33	12.4	2.54	14.8	3.02	17.2	3.15	18.4	3.72	19.9	3.91	22.6	4.51	24.4	5.16
	35	12.4	2.71	14.8	3.23	17.2	3.36	18.4	3.83	19.9	4.14	22.6	4.79	24.4	5.48
	37	12.4	2.89	14.8	3.46	17.2	3.58	18.4	4.00	19.9	4.39	22.6	5.08	24.4	5.83
	39	12.4	3.07	14.8	3.70	17.2	3.82	18.4	4.16	19.9	4.65	22.6	5.39	24.4	6.18
	41	12.4	3.19	14.8	3.84	17.2	3.96	18.4	4.31	19.9	4.86	22.6	5.67	24.4	6.47
43	12.4	3.30	14.8	3.92	17.2	4.11	18.4	4.59	19.9	4.98	22.6	5.96	24.4	6.76	
45	12.4	3.46	14.8	4.41	17.2	4.70	18.4	5.07	19.9	5.57	22.6	6.54	24.4	7.05	
48	12.4	4.06	14.8	4.63	17.2	5.21	18.4	5.78	19.9	6.36	22.6	6.93	24.4	7.51	
50	12.4	4.67	14.8	5.24	17.2	5.81	18.4	6.39	19.9	6.96	22.6	7.54	24.4	8.11	
52	12.4	5.27	14.8	5.85	17.2	6.42	18.4	6.99	19.9	7.57	22.6	8.14	24.4	8.72	
54	12.4	5.88	14.8	6.45	17.2	7.03	18.4	7.60	19.9	8.17	22.6	8.75	24.4	9.32	

Обозначения:

ТС: Полная производительность (кВт)

PI: Потребляемая мощность (компрессор + двигатель вентилятора наружного блока) (кВт)

MVS FDC II-S

Таблица 2-8.23: Частичная холодильная нагрузка для блоков производительностью 28 л.с.

Частичная нагрузка	Температура наружного воздуха (°CDB)	Температура в помещении (°C DB/WD)													
		20.8/14		23.3/16		25.8/18		27/19		28.2/20		30.7/22		32/24	
		ТС	PI	ТС	PI	ТС	PI	ТС	PI	ТС	PI	ТС	PI	ТС	PI
		кВт	кВт	кВт	кВт	кВт	кВт	кВт	кВт	кВт	кВт	кВт	кВт	кВт	кВт
100%	-5	55.1	8.92	64.7	9.72	77.4	10.72	78.5	12.58	85.1	12.29	97.8	13.61	100.8	15.00
	-2	55.1	9.05	64.7	9.84	77.4	10.93	78.5	12.68	85.1	12.46	97.8	13.78	100.8	15.10
	0	55.1	9.15	64.7	9.97	77.4	11.12	78.5	12.87	85.1	12.58	97.8	14.03	100.8	15.28
	2	55.1	9.28	64.7	10.09	77.4	11.37	78.5	12.99	85.1	12.73	97.8	14.25	100.8	15.53
	4	55.1	9.37	64.7	10.27	77.4	11.52	78.5	13.18	85.1	12.91	97.8	14.40	100.8	15.70
	6	55.1	9.57	64.7	10.42	77.4	11.71	78.5	13.46	85.1	13.11	97.8	14.63	100.8	15.95
	8	55.1	9.72	64.7	10.64	77.4	11.93	78.5	13.70	85.1	13.33	97.8	14.88	100.8	16.22
	10	55.1	9.91	64.7	10.83	77.4	12.12	78.5	13.92	85.1	13.59	97.8	15.14	100.8	16.46
	12	55.1	10.12	64.7	11.06	77.4	12.58	78.5	14.19	85.1	13.86	97.8	15.45	99.4	16.59
	14	55.1	10.32	64.7	11.30	77.4	13.17	78.5	15.10	85.1	14.13	97.8	15.78	98.3	16.80
	16	55.1	10.52	64.7	11.57	77.4	13.49	78.5	15.48	85.1	14.43	94.9	15.98	96.9	17.00
	18	55.1	10.72	64.7	11.80	77.4	14.00	78.5	16.09	85.1	14.74	93.8	16.55	95.8	17.44
	20	55.1	10.95	64.7	12.21	77.4	15.17	78.5	17.18	85.1	15.84	92.4	17.39	94.4	18.31
	21	55.1	11.05	64.7	12.71	77.4	16.25	78.5	18.23	85.1	16.41	91.8	17.83	93.8	18.74
	23	55.1	11.83	64.7	13.72	77.4	17.48	78.5	19.48	85.1	17.66	90.7	18.70	92.4	19.62
	25	55.1	12.67	64.7	14.79	77.4	18.86	78.5	20.46	85.1	18.97	89.3	19.58	91.3	20.49
	27	55.1	13.54	64.7	15.90	77.4	19.97	78.5	21.69	85.1	20.34	87.9	20.45	89.9	21.40
	29	55.1	14.48	64.7	17.08	77.4	21.48	78.5	22.33	84.8	21.65	86.8	22.10	88.8	22.27
	31	55.1	15.49	64.7	18.32	77.4	22.96	78.5	22.74	83.7	22.53	85.4	22.90	87.4	23.18
	33	55.1	16.53	64.7	19.63	77.4	24.06	78.5	23.38	82.3	23.40	84.3	23.74	86.2	24.09
	35	55.1	17.60	64.7	21.04	77.4	24.55	78.5	24.92	80.9	24.96	82.9	25.21	84.8	25.46
	37	55.1	18.78	64.7	22.52	77.4	24.73	77.5	26.05	80.1	26.43	81.7	26.76	83.4	27.11
	39	55.1	19.99	64.7	24.06	77.4	25.17	76.5	27.07	79.0	27.53	80.4	28.07	82.3	28.30
	41	55.1	20.74	64.7	25.00	77.4	25.55	75.5	28.04	77.9	28.61	77.4	28.88	81.1	29.19
43	55.1	21.48	64.7	25.49	77.4	26.40	75.3	29.37	76.8	29.84	77.9	30.35	78.2	30.58	
45	55.1	22.48	64.7	26.20	77.4	28.05	74.8	31.23	75.7	32.96	77.2	34.61	76.9	35.28	
48	55.1	25.92	64.7	27.91	77.4	29.91	73.9	33.64	74.6	35.64	75.5	37.63	75.8	39.63	
50	55.1	29.36	64.7	31.35	77.4	33.35	73.2	35.34	73.5	37.33	74.3	39.33	74.6	41.32	
52	55.1	32.80	64.7	34.79	77.4	36.78	72.6	38.78	72.4	40.77	73.1	42.77	73.5	44.76	
54	55.1	36.24	64.7	38.23	77.4	40.22	71.9	42.22	71.3	44.21	72.0	46.20	72.3	48.20	
75%	-5	39.8	5.23	47.6	5.41	55.2	6.28	59.1	7.25	64.2	7.80	72.9	8.97	78.4	10.27
	-2	39.8	5.30	47.6	5.47	55.2	6.37	59.1	7.29	64.2	7.90	72.9	9.06	78.4	10.38
	0	39.8	5.36	47.6	5.54	55.2	6.47	59.1	7.32	64.2	8.00	72.9	9.16	78.4	10.46
	2	39.8	5.44	47.6	5.61	55.2	6.55	59.1	7.53	64.2	8.12	72.9	9.35	78.4	10.61
	4	39.8	5.49	47.6	5.70	55.2	6.66	59.1	7.64	64.2	8.23	72.9	9.50	78.4	10.76
	6	39.8	5.61	47.6	5.82	55.2	6.80	59.1	7.79	64.2	8.37	72.9	9.65	78.4	10.95
	8	39.8	5.70	47.6	5.93	55.2	6.94	59.1	7.92	64.2	8.52	72.9	9.82	78.4	11.05
	10	39.8	5.81	47.6	6.07	55.2	7.08	59.1	8.06	64.2	8.71	72.9	9.95	78.4	11.22
	12	39.8	5.93	47.6	6.18	55.2	7.21	59.1	8.21	64.2	8.87	72.9	10.14	78.4	11.43
	14	39.8	6.05	47.6	6.30	55.2	7.35	59.1	8.48	64.2	9.04	72.9	10.33	78.4	11.64
	16	39.8	6.17	47.6	6.42	55.2	7.51	59.1	8.51	64.2	9.22	72.9	10.53	78.4	11.85
	18	39.8	6.29	47.6	6.55	55.2	7.65	59.1	8.53	64.2	9.40	72.9	10.74	78.4	12.22
	20	39.8	6.42	47.6	6.71	55.2	7.81	59.1	9.09	64.2	9.75	72.9	11.55	78.4	12.79
	21	39.8	6.48	47.6	6.76	55.2	7.95	59.1	9.73	64.2	10.10	72.9	11.96	78.4	13.09
	23	39.8	6.94	47.6	7.04	55.2	8.55	59.1	10.26	64.2	10.83	72.9	12.84	78.4	13.69
	25	39.8	7.43	47.6	7.54	55.2	9.17	59.1	11.02	64.2	11.57	72.9	13.74	78.4	14.29
	27	39.8	7.94	47.6	8.05	55.2	9.82	59.1	11.81	64.2	12.38	72.9	14.71	78.4	14.89
	29	39.8	8.49	47.6	8.60	55.2	10.51	59.1	12.36	64.2	13.23	72.9	15.37	78.4	15.49
	31	39.8	9.08	47.6	9.18	55.2	11.22	59.1	13.18	64.2	14.11	72.9	15.97	78.4	16.11
	33	39.8	9.69	47.6	9.78	55.2	12.01	59.1	13.97	64.2	15.05	72.9	16.59	78.4	16.71
	35	39.8	10.32	47.6	10.42	55.2	12.81	59.1	14.61	64.2	16.04	72.9	17.20	78.4	17.33
	37	39.8	11.01	47.6	11.09	55.2	13.67	59.1	15.28	64.2	17.10	72.9	17.79	78.4	17.93
	39	39.8	11.72	47.6	11.83	55.2	14.57	59.1	15.87	64.2	18.24	72.9	18.42	78.4	18.55
	41	39.8	12.16	47.6	12.38	55.2	15.11	59.1	16.44	64.2	18.32	72.9	18.88	78.4	18.99
43	39.8	12.60	47.6	12.93	55.2	15.66	59.1	17.22	64.2	18.71	72.9	19.13	78.4	19.29	
45	39.8	13.18	47.6	13.59	55.2	16.32	59.1	18.31	64.2	19.23	72.9	20.79	78.4	21.68	
48	39.8	15.20	47.6	16.66	55.2	18.12	59.1	19.58	64.2	21.04	72.9	22.51	78.4	23.97	
50	39.8	17.22	47.6	18.68	55.2	20.14	59.1	21.60	64.2	23.06	72.9	24.52	78.4	25.98	
52	39.8	19.23	47.6	20.69	55.2	22.15	59.1	23.62	64.2	25.08	72.9	26.54	78.4	28.00	
54	39.8	21.25	47.6	22.71	55.2	24.17	59.1	25.63	64.2	27.09	72.9	28.56	78.4	30.02	

Обозначения:

ТС: Полная производительность (кВт)

PI: Потребляемая мощность (компрессор + двигатель вентилятора наружного блока) (кВт)

Продолжение таблицы на следующей странице...

Таблица 2-8.23: Частичная холодильная нагрузка для блоков производительностью 28 л.с. (продолжение)

Частичная нагрузка	Температура наружного воздуха (°CDB)	Температура в помещении (°C DB/WD)													
		20.8/14		23.3/16		25.8/18		27/19		28.2/20		30.7/22		32/24	
		ТС	PI	ТС	PI	ТС	PI	ТС	PI	ТС	PI	ТС	PI	ТС	PI
		кВт	кВт	кВт	кВт	кВт	кВт	кВт	кВт	кВт	кВт	кВт	кВт	кВт	кВт
50%	-5	26.7	2.93	31.9	3.19	37.0	3.52	39.6	4.50	43.0	4.91	49.0	5.46	52.6	6.26
	-2	26.7	2.97	31.9	3.23	37.0	3.57	39.6	4.57	43.0	4.99	49.0	5.54	52.6	6.30
	0	26.7	3.00	31.9	3.27	37.0	3.63	39.6	4.62	43.0	5.06	49.0	5.62	52.6	6.38
	2	26.7	3.05	31.9	3.31	37.0	3.67	39.6	4.71	43.0	5.13	49.0	5.74	52.6	6.47
	4	26.7	3.08	31.9	3.37	37.0	3.73	39.6	4.77	43.0	5.24	49.0	5.83	52.6	6.56
	6	26.7	3.14	31.9	3.42	37.0	3.81	39.6	4.88	43.0	5.34	49.0	5.94	52.6	6.71
	8	26.7	3.19	31.9	3.49	37.0	3.89	39.6	4.97	43.0	5.45	49.0	6.06	52.6	6.82
	10	26.7	3.26	31.9	3.56	37.0	3.96	39.6	5.11	43.0	5.54	49.0	6.17	52.6	6.80
	12	26.7	3.32	31.9	3.63	37.0	4.04	39.6	5.20	43.0	5.65	49.0	6.29	52.6	6.92
	14	26.7	3.39	31.9	3.71	37.0	4.12	39.6	5.29	43.0	5.74	49.0	6.40	52.6	7.03
	16	26.7	3.45	31.9	3.80	37.0	4.21	39.6	5.38	43.0	5.86	49.0	6.51	52.6	7.17
	18	26.7	3.52	31.9	3.88	37.0	4.28	39.6	5.47	43.0	5.97	49.0	6.62	52.6	7.30
	20	26.7	3.60	31.9	4.01	37.0	4.38	39.6	5.58	43.0	6.01	49.0	6.76	52.6	7.44
	21	26.7	3.63	31.9	4.17	37.0	4.45	39.6	5.99	43.0	6.13	49.0	6.83	52.6	7.60
	23	26.7	3.88	31.9	4.51	37.0	4.79	39.6	6.39	43.0	6.51	49.0	7.10	52.6	7.66
	25	26.7	4.16	31.9	4.86	37.0	5.14	39.6	6.75	43.0	6.94	49.0	7.57	52.6	8.16
	27	26.7	4.45	31.9	5.22	37.0	5.50	39.6	7.08	43.0	7.39	49.0	8.07	52.6	8.70
	29	26.7	4.76	31.9	5.61	37.0	5.89	39.6	7.38	43.0	7.87	49.0	8.61	52.6	9.29
	31	26.7	5.09	31.9	6.02	37.0	6.29	39.6	7.79	43.0	8.36	49.0	9.16	52.6	9.92
	33	26.7	5.43	31.9	6.45	37.0	6.72	39.6	8.12	43.0	8.88	49.0	9.74	52.6	10.56
	35	26.7	5.78	31.9	6.91	37.0	7.18	39.6	8.18	43.0	9.43	49.0	10.38	52.6	11.26
	37	26.7	6.17	31.9	7.39	37.0	7.65	39.6	8.56	43.0	10.02	49.0	11.03	52.6	11.98
	39	26.7	6.56	31.9	7.90	37.0	8.16	39.6	8.89	43.0	10.38	49.0	11.71	52.6	12.75
	41	26.7	6.81	31.9	8.21	37.0	8.46	39.6	9.21	43.0	10.75	49.0	12.26	52.6	13.56
43	26.7	7.06	31.9	8.37	37.0	8.77	39.6	9.64	43.0	11.28	49.0	12.78	52.6	14.18	
45	26.7	7.63	31.9	9.42	37.0	9.96	39.6	10.50	43.0	12.19	49.0	13.36	52.6	14.79	
48	26.7	8.76	31.9	9.82	37.0	10.89	39.6	11.95	43.0	13.01	49.0	14.08	52.6	15.14	
50	26.7	9.89	31.9	10.95	37.0	12.01	39.6	13.08	43.0	14.14	49.0	15.21	52.6	16.27	
52	26.7	11.02	31.9	12.08	37.0	13.14	39.6	14.21	43.0	15.27	49.0	16.34	52.6	17.40	
54	26.7	12.15	31.9	13.21	37.0	14.27	39.6	15.34	43.0	16.40	49.0	17.46	52.6	18.53	
25%	-5	13.3	1.59	15.9	1.73	18.5	1.91	19.7	2.62	21.4	2.72	24.3	3.09	26.2	3.33
	-2	13.3	1.61	15.9	1.76	18.5	1.94	19.7	2.69	21.4	2.77	24.3	3.13	26.2	3.38
	0	13.3	1.63	15.9	1.78	18.5	1.97	19.7	2.70	21.4	2.80	24.3	3.19	26.2	3.44
	2	13.3	1.66	15.9	1.80	18.5	1.99	19.7	2.71	21.4	2.85	24.3	3.20	26.2	3.50
	4	13.3	1.67	15.9	1.83	18.5	2.03	19.7	2.71	21.4	2.91	24.3	3.28	26.2	3.59
	6	13.3	1.71	15.9	1.86	18.5	2.07	19.7	2.74	21.4	2.96	24.3	3.33	26.2	3.70
	8	13.3	1.73	15.9	1.90	18.5	2.11	19.7	2.75	21.4	3.00	24.3	3.38	26.2	3.82
	10	13.3	1.77	15.9	1.93	18.5	2.15	19.7	2.72	21.4	3.09	24.3	3.47	26.2	3.87
	12	13.3	1.80	15.9	1.97	18.5	2.19	19.7	2.74	21.4	3.15	24.3	3.53	26.2	3.94
	14	13.3	1.84	15.9	2.02	18.5	2.24	19.7	2.75	21.4	3.20	24.3	3.60	26.2	4.01
	16	13.3	1.88	15.9	2.06	18.5	2.29	19.7	2.76	21.4	3.24	24.3	3.66	26.2	4.08
	18	13.3	1.91	15.9	2.11	18.5	2.33	19.7	2.77	21.4	3.30	24.3	3.72	26.2	4.15
	20	13.3	1.95	15.9	2.18	18.5	2.38	19.7	2.90	21.4	3.36	24.3	3.78	26.2	4.23
	21	13.3	1.97	15.9	2.27	18.5	2.42	19.7	3.05	21.4	3.40	24.3	3.83	26.2	4.28
	23	13.3	2.11	15.9	2.45	18.5	2.60	19.7	3.25	21.4	3.46	24.3	3.89	26.2	4.37
	25	13.3	2.26	15.9	2.64	18.5	2.79	19.7	3.46	21.4	3.57	24.3	4.09	26.2	4.66
	27	13.3	2.42	15.9	2.84	18.5	2.99	19.7	3.73	21.4	3.78	24.3	4.35	26.2	4.97
	29	13.3	2.58	15.9	3.05	18.5	3.20	19.7	3.84	21.4	4.03	24.3	4.63	26.2	5.29
	31	13.3	2.76	15.9	3.27	18.5	3.41	19.7	4.10	21.4	4.28	24.3	4.92	26.2	5.63
	33	13.3	2.95	15.9	3.50	18.5	3.65	19.7	4.32	21.4	4.54	24.3	5.23	26.2	5.99
	35	13.3	3.14	15.9	3.75	18.5	3.90	19.7	4.45	21.4	4.80	24.3	5.56	26.2	6.36
	37	13.3	3.35	15.9	4.02	18.5	4.16	19.7	4.65	21.4	5.09	24.3	5.90	26.2	6.76
	39	13.3	3.57	15.9	4.29	18.5	4.43	19.7	4.83	21.4	5.40	24.3	6.25	26.2	7.18
	41	13.3	3.70	15.9	4.46	18.5	4.60	19.7	5.00	21.4	5.64	24.3	6.59	26.2	7.51
43	13.3	3.83	15.9	4.55	18.5	4.76	19.7	5.33	21.4	5.78	24.3	6.92	26.2	7.84	
45	13.3	4.01	15.9	5.12	18.5	5.45	19.7	5.88	21.4	6.46	24.3	7.59	26.2	8.18	
48	13.3	4.71	15.9	5.38	18.5	6.05	19.7	6.71	21.4	7.38	24.3	8.05	26.2	8.71	
50	13.3	5.42	15.9	6.08	18.5	6.75	19.7	7.42	21.4	8.08	24.3	8.75	26.2	9.42	
52	13.3	6.12	15.9	6.78	18.5	7.45	19.7	8.12	21.4	8.79	24.3	9.45	26.2	10.12	
54	13.3	6.82	15.9	7.49	18.5	8.15	19.7	8.82	21.4	9.49	24.3	10.15	26.2	10.82	

Обозначения:

ТС: Полная производительность (кВт)

PI: Потребляемая мощность (компрессор + двигатель вентилятора наружного блока) (кВт)

MVS FDC II-S

Таблица 2-8.24: Частичная холодильная нагрузка для блоков производительностью 30 л.с.

Частичная нагрузка	Температура наружного воздуха (°CDB)	Температура в помещении (°C DB/WD)													
		20.8/14		23.3/16		25.8/18		27/19		28.2/20		30.7/22		32/24	
		ТС	PI	ТС	PI	ТС	PI	ТС	PI	ТС	PI	ТС	PI	ТС	PI
		кВт	кВт	кВт	кВт	кВт	кВт	кВт	кВт	кВт	кВт	кВт	кВт	кВт	кВт
100%	-5	59.6	10.14	70.0	11.05	83.8	12.18	85.0	14.30	92.2	13.97	105.9	15.47	109.2	17.05
	-2	59.6	10.28	70.0	11.19	83.8	12.43	85.0	14.41	92.2	14.17	105.9	15.67	109.2	17.17
	0	59.6	10.40	70.0	11.33	83.8	12.64	85.0	14.63	92.2	14.31	105.9	15.95	109.2	17.37
	2	59.6	10.55	70.0	11.47	83.8	12.92	85.0	14.77	92.2	14.48	105.9	16.20	109.2	17.65
	4	59.6	10.65	70.0	11.67	83.8	13.09	85.0	14.98	92.2	14.67	105.9	16.37	109.2	17.85
	6	59.6	10.88	70.0	11.84	83.8	13.32	85.0	15.30	92.2	14.90	105.9	16.63	109.2	18.13
	8	59.6	11.05	70.0	12.09	83.8	13.56	85.0	15.58	92.2	15.16	105.9	16.91	109.2	18.44
	10	59.6	11.27	70.0	12.31	83.8	13.78	85.0	15.82	92.2	15.45	105.9	17.22	109.2	18.71
	12	59.6	11.50	70.0	12.58	83.8	14.30	85.0	16.14	92.2	15.76	105.9	17.56	107.6	18.86
	14	59.6	11.73	70.0	12.85	83.8	14.97	85.0	17.16	92.2	16.06	105.9	17.94	106.4	19.10
	16	59.6	11.96	70.0	13.15	83.8	15.33	85.0	17.60	92.2	16.41	102.8	18.17	104.9	19.33
	18	59.6	12.18	70.0	13.42	83.8	15.92	85.0	18.29	92.2	16.75	101.6	18.82	103.7	19.82
	20	59.6	12.45	70.0	13.88	83.8	17.25	85.0	19.53	92.2	18.01	100.1	19.77	102.2	20.81
	21	59.6	12.57	70.0	14.45	83.8	18.47	85.0	20.72	92.2	18.66	99.5	20.27	101.6	21.31
	23	59.6	13.45	70.0	15.60	83.8	19.87	85.0	22.15	92.2	20.07	98.2	21.26	100.1	22.30
	25	59.6	14.40	70.0	16.82	83.8	21.44	85.0	23.26	92.2	21.56	96.7	22.26	98.8	23.30
	27	59.6	15.39	70.0	18.08	83.8	22.71	85.0	24.66	92.2	23.13	95.2	23.25	97.3	24.33
	29	59.6	16.46	70.0	19.41	83.8	24.41	85.0	25.39	91.9	24.62	94.0	25.13	96.1	25.32
	31	59.6	17.61	70.0	20.83	83.8	26.11	85.0	25.85	90.6	25.61	92.5	26.03	94.6	26.35
	33	59.6	18.79	70.0	22.32	83.8	27.35	85.0	26.58	89.1	26.60	91.3	26.99	93.4	27.38
	35	59.6	20.01	70.0	23.92	83.8	27.91	85.0	28.33	87.6	28.38	89.7	28.66	91.9	28.94
	37	59.6	21.35	70.0	25.60	83.8	28.11	83.9	29.62	86.7	30.04	88.5	30.42	90.3	30.82
	39	59.6	22.72	70.0	27.36	83.8	28.62	82.8	30.77	85.5	31.29	87.0	31.91	89.1	32.17
	41	59.6	23.57	70.0	28.42	83.8	29.04	81.8	31.87	84.4	32.53	83.8	32.84	87.9	33.18
43	59.6	24.42	70.0	28.98	83.8	30.01	81.5	33.39	83.2	33.92	84.3	34.50	84.6	34.76	
45	59.6	25.56	70.0	29.78	83.8	31.89	81.0	35.51	82.0	37.47	83.6	39.35	83.3	40.11	
48	59.6	29.47	70.0	31.73	83.8	34.00	80.0	38.25	80.8	40.51	81.7	42.78	82.0	45.05	
50	59.6	33.38	70.0	35.64	83.8	37.91	79.3	40.17	79.6	42.44	80.4	44.71	80.8	46.97	
52	59.6	37.29	70.0	39.55	83.8	41.82	78.6	44.08	78.4	46.35	79.2	48.62	79.6	50.88	
54	59.6	41.19	70.0	43.46	83.8	45.73	77.8	47.99	77.3	50.26	77.9	52.53	78.3	54.79	
75%	-5	43.1	5.95	51.6	6.15	59.8	7.14	64.0	8.24	69.5	8.87	79.0	10.20	84.9	11.68
	-2	43.1	6.03	51.6	6.21	59.8	7.24	64.0	8.29	69.5	8.98	79.0	10.30	84.9	11.80
	0	43.1	6.10	51.6	6.30	59.8	7.36	64.0	8.33	69.5	9.09	79.0	10.42	84.9	11.89
	2	43.1	6.18	51.6	6.38	59.8	7.44	64.0	8.56	69.5	9.24	79.0	10.63	84.9	12.06
	4	43.1	6.25	51.6	6.48	59.8	7.58	64.0	8.69	69.5	9.35	79.0	10.80	84.9	12.24
	6	43.1	6.38	51.6	6.61	59.8	7.72	64.0	8.86	69.5	9.52	79.0	10.97	84.9	12.44
	8	43.1	6.48	51.6	6.74	59.8	7.89	64.0	9.01	69.5	9.68	79.0	11.17	84.9	12.56
	10	43.1	6.61	51.6	6.90	59.8	8.04	64.0	9.17	69.5	9.90	79.0	11.31	84.9	12.76
	12	43.1	6.74	51.6	7.03	59.8	8.20	64.0	9.33	69.5	10.09	79.0	11.53	84.9	13.00
	14	43.1	6.88	51.6	7.16	59.8	8.36	64.0	9.64	69.5	10.27	79.0	11.74	84.9	13.23
	16	43.1	7.01	51.6	7.29	59.8	8.54	64.0	9.67	69.5	10.48	79.0	11.97	84.9	13.47
	18	43.1	7.15	51.6	7.45	59.8	8.70	64.0	9.70	69.5	10.69	79.0	12.21	84.9	13.89
	20	43.1	7.30	51.6	7.63	59.8	8.88	64.0	10.33	69.5	11.08	79.0	13.13	84.9	14.54
	21	43.1	7.37	51.6	7.69	59.8	9.04	64.0	11.06	69.5	11.48	79.0	13.60	84.9	14.88
	23	43.1	7.88	51.6	8.00	59.8	9.72	64.0	11.67	69.5	12.32	79.0	14.59	84.9	15.56
	25	43.1	8.44	51.6	8.58	59.8	10.43	64.0	12.53	69.5	13.15	79.0	15.62	84.9	16.25
	27	43.1	9.03	51.6	9.15	59.8	11.16	64.0	13.42	69.5	14.07	79.0	16.72	84.9	16.93
	29	43.1	9.65	51.6	9.78	59.8	11.95	64.0	14.05	69.5	15.04	79.0	17.48	84.9	17.61
	31	43.1	10.32	51.6	10.44	59.8	12.76	64.0	14.98	69.5	16.04	79.0	18.16	84.9	18.32
	33	43.1	11.02	51.6	11.12	59.8	13.65	64.0	15.88	69.5	17.11	79.0	18.87	84.9	19.00
	35	43.1	11.74	51.6	11.85	59.8	14.57	64.0	16.61	69.5	18.24	79.0	19.55	84.9	19.70
	37	43.1	12.52	51.6	12.61	59.8	15.54	64.0	17.37	69.5	19.44	79.0	20.23	84.9	20.39
	39	43.1	13.33	51.6	13.45	59.8	16.56	64.0	18.04	69.5	20.73	79.0	20.94	84.9	21.09
	41	43.1	13.82	51.6	14.07	59.8	17.18	64.0	18.69	69.5	20.83	79.0	21.47	84.9	21.59
43	43.1	14.32	51.6	14.70	59.8	17.81	64.0	19.58	69.5	21.27	79.0	21.75	84.9	21.93	
45	43.1	14.99	51.6	15.44	59.8	18.55	64.0	20.82	69.5	21.86	79.0	23.64	84.9	24.65	
48	43.1	17.28	51.6	18.94	59.8	20.60	64.0	22.26	69.5	23.92	79.0	25.59	84.9	27.25	
50	43.1	19.57	51.6	21.23	59.8	22.89	64.0	24.56	69.5	26.22	79.0	27.88	84.9	29.54	
52	43.1	21.86	51.6	23.53	59.8	25.19	64.0	26.85	69.5	28.51	79.0	30.17	84.9	31.83	
54	43.1	24.16	51.6	25.82	59.8	27.48	64.0	29.14	69.5	30.80	79.0	32.46	84.9	34.12	

Обозначения:

ТС: Полная производительность (кВт)

PI: Потребляемая мощность (компрессор + двигатель вентилятора наружного блока) (кВт)

Продолжение таблицы на следующей странице...

Таблица 2-8.24: Частичная холодильная нагрузка для блоков производительностью 30 л.с. (продолжение)

Частичная нагрузка	Температура наружного воздуха (°CDB)	Температура в помещении (°C DB/WD)													
		20.8/14		23.3/16		25.8/18		27/19		28.2/20		30.7/22		32/24	
		ТС	PI	ТС	PI	ТС	PI	ТС	PI	ТС	PI	ТС	PI	ТС	PI
		кВт	кВт	кВт	кВт	кВт	кВт	кВт	кВт	кВт	кВт	кВт	кВт	кВт	кВт
50%	-5	28.9	3.33	34.5	3.63	40.1	4.00	42.9	5.12	46.6	5.58	53.1	6.21	57.0	7.12
	-2	28.9	3.38	34.5	3.67	40.1	4.06	42.9	5.19	46.6	5.68	53.1	6.30	57.0	7.16
	0	28.9	3.41	34.5	3.72	40.1	4.12	42.9	5.26	46.6	5.75	53.1	6.39	57.0	7.26
	2	28.9	3.46	34.5	3.77	40.1	4.17	42.9	5.36	46.6	5.84	53.1	6.52	57.0	7.35
	4	28.9	3.50	34.5	3.83	40.1	4.24	42.9	5.42	46.6	5.95	53.1	6.62	57.0	7.45
	6	28.9	3.57	34.5	3.89	40.1	4.33	42.9	5.54	46.6	6.08	53.1	6.76	57.0	7.63
	8	28.9	3.63	34.5	3.97	40.1	4.42	42.9	5.65	46.6	6.19	53.1	6.88	57.0	7.75
	10	28.9	3.70	34.5	4.04	40.1	4.50	42.9	5.81	46.6	6.30	53.1	7.02	57.0	7.74
	12	28.9	3.78	34.5	4.13	40.1	4.59	42.9	5.91	46.6	6.43	53.1	7.15	57.0	7.86
	14	28.9	3.85	34.5	4.22	40.1	4.68	42.9	6.01	46.6	6.53	53.1	7.27	57.0	7.99
	16	28.9	3.93	34.5	4.32	40.1	4.78	42.9	6.12	46.6	6.66	53.1	7.40	57.0	8.15
	18	28.9	4.00	34.5	4.41	40.1	4.87	42.9	6.22	46.6	6.79	53.1	7.53	57.0	8.30
	20	28.9	4.09	34.5	4.56	40.1	4.97	42.9	6.35	46.6	6.84	53.1	7.68	57.0	8.46
	21	28.9	4.13	34.5	4.75	40.1	5.06	42.9	6.81	46.6	6.96	53.1	7.76	57.0	8.64
	23	28.9	4.42	34.5	5.12	40.1	5.44	42.9	7.27	46.6	7.40	53.1	8.07	57.0	8.71
	25	28.9	4.73	34.5	5.52	40.1	5.84	42.9	7.67	46.6	7.89	53.1	8.61	57.0	9.28
	27	28.9	5.05	34.5	5.94	40.1	6.25	42.9	8.05	46.6	8.40	53.1	9.18	57.0	9.89
	29	28.9	5.41	34.5	6.38	40.1	6.69	42.9	8.39	46.6	8.94	53.1	9.79	57.0	10.56
	31	28.9	5.78	34.5	6.84	40.1	7.15	42.9	8.85	46.6	9.51	53.1	10.41	57.0	11.28
	33	28.9	6.17	34.5	7.33	40.1	7.64	42.9	9.23	46.6	10.10	53.1	11.08	57.0	12.00
	35	28.9	6.57	34.5	7.86	40.1	8.16	42.9	9.30	46.6	10.72	53.1	11.80	57.0	12.80
	37	28.9	7.01	34.5	8.41	40.1	8.70	42.9	9.73	46.6	11.39	53.1	12.54	57.0	13.62
	39	28.9	7.46	34.5	8.98	40.1	9.27	42.9	10.10	46.6	11.80	53.1	13.31	57.0	14.49
	41	28.9	7.74	34.5	9.33	40.1	9.62	42.9	10.47	46.6	12.22	53.1	13.94	57.0	15.42
43	28.9	8.02	34.5	9.52	40.1	9.97	42.9	10.96	46.6	12.82	53.1	14.53	57.0	16.12	
45	28.9	8.67	34.5	10.71	40.1	11.32	42.9	11.94	46.6	13.86	53.1	15.18	57.0	16.82	
48	28.9	9.96	34.5	11.17	40.1	12.37	42.9	13.58	46.6	14.79	53.1	16.00	57.0	17.21	
50	28.9	11.24	34.5	12.45	40.1	13.66	42.9	14.87	46.6	16.08	53.1	17.29	57.0	18.50	
52	28.9	12.52	34.5	13.73	40.1	14.94	42.9	16.15	46.6	17.36	53.1	18.57	57.0	19.78	
54	28.9	13.81	34.5	15.02	40.1	16.23	42.9	17.44	46.6	18.65	53.1	19.85	57.0	21.06	
25%	-5	14.4	1.81	17.3	1.97	20.0	2.17	21.4	2.98	23.2	3.09	26.4	3.52	28.4	3.79
	-2	14.4	1.83	17.3	2.00	20.0	2.20	21.4	3.05	23.2	3.15	26.4	3.56	28.4	3.84
	0	14.4	1.85	17.3	2.02	20.0	2.24	21.4	3.07	23.2	3.18	26.4	3.62	28.4	3.91
	2	14.4	1.88	17.3	2.05	20.0	2.26	21.4	3.08	23.2	3.24	26.4	3.64	28.4	3.98
	4	14.4	1.90	17.3	2.08	20.0	2.30	21.4	3.09	23.2	3.31	26.4	3.73	28.4	4.08
	6	14.4	1.94	17.3	2.11	20.0	2.35	21.4	3.11	23.2	3.37	26.4	3.79	28.4	4.20
	8	14.4	1.97	17.3	2.16	20.0	2.40	21.4	3.12	23.2	3.41	26.4	3.85	28.4	4.34
	10	14.4	2.01	17.3	2.20	20.0	2.45	21.4	3.09	23.2	3.51	26.4	3.95	28.4	4.40
	12	14.4	2.05	17.3	2.24	20.0	2.50	21.4	3.11	23.2	3.58	26.4	4.02	28.4	4.47
	14	14.4	2.09	17.3	2.29	20.0	2.54	21.4	3.13	23.2	3.63	26.4	4.09	28.4	4.56
	16	14.4	2.13	17.3	2.35	20.0	2.60	21.4	3.13	23.2	3.69	26.4	4.16	28.4	4.63
	18	14.4	2.17	17.3	2.39	20.0	2.65	21.4	3.15	23.2	3.76	26.4	4.23	28.4	4.72
	20	14.4	2.22	17.3	2.48	20.0	2.70	21.4	3.30	23.2	3.83	26.4	4.30	28.4	4.81
	21	14.4	2.24	17.3	2.58	20.0	2.75	21.4	3.46	23.2	3.86	26.4	4.35	28.4	4.86
	23	14.4	2.40	17.3	2.78	20.0	2.96	21.4	3.70	23.2	3.93	26.4	4.42	28.4	4.97
	25	14.4	2.57	17.3	3.00	20.0	3.17	21.4	3.93	23.2	4.05	26.4	4.65	28.4	5.30
	27	14.4	2.75	17.3	3.23	20.0	3.40	21.4	4.24	23.2	4.30	26.4	4.95	28.4	5.65
	29	14.4	2.94	17.3	3.46	20.0	3.63	21.4	4.37	23.2	4.58	26.4	5.26	28.4	6.02
	31	14.4	3.14	17.3	3.72	20.0	3.88	21.4	4.66	23.2	4.86	26.4	5.60	28.4	6.41
	33	14.4	3.35	17.3	3.98	20.0	4.15	21.4	4.91	23.2	5.16	26.4	5.95	28.4	6.81
	35	14.4	3.57	17.3	4.27	20.0	4.43	21.4	5.05	23.2	5.46	26.4	6.32	28.4	7.23
	37	14.4	3.81	17.3	4.57	20.0	4.73	21.4	5.28	23.2	5.79	26.4	6.70	28.4	7.69
	39	14.4	4.05	17.3	4.88	20.0	5.04	21.4	5.49	23.2	6.14	26.4	7.11	28.4	8.16
	41	14.4	4.21	17.3	5.07	20.0	5.23	21.4	5.69	23.2	6.41	26.4	7.49	28.4	8.54
43	14.4	4.36	17.3	5.17	20.0	5.42	21.4	6.06	23.2	6.57	26.4	7.87	28.4	8.92	
45	14.4	4.56	17.3	5.82	20.0	6.20	21.4	6.69	23.2	7.34	26.4	8.62	28.4	9.30	
48	14.4	5.36	17.3	6.12	20.0	6.87	21.4	7.63	23.2	8.39	26.4	9.15	28.4	9.91	
50	14.4	6.16	17.3	6.91	20.0	7.67	21.4	8.43	23.2	9.19	26.4	9.95	28.4	10.71	
52	14.4	6.95	17.3	7.71	20.0	8.47	21.4	9.23	23.2	9.99	26.4	10.75	28.4	11.50	
54	14.4	7.75	17.3	8.51	20.0	9.27	21.4	10.03	23.2	10.79	26.4	11.54	28.4	12.30	

Обозначения:

ТС: Полная производительность (кВт)

PI: Потребляемая мощность (компрессор + двигатель вентилятора наружного блока) (кВт)

MVS FDC II-S

Таблица 2-8.24: Частичная холодильная нагрузка для блоков производительностью 32 л.с.

Частичная нагрузка	Температура наружного воздуха (°CDB)	Температура в помещении (°C DB/WD)													
		20.8/14		23.3/16		25.8/18		27/19		28.2/20		30.7/22		32/24	
		ТС	PI	ТС	PI	ТС	PI	ТС	PI	ТС	PI	ТС	PI	ТС	PI
		кВт	кВт	кВт	кВт	кВт	кВт	кВт	кВт	кВт	кВт	кВт	кВт	кВт	кВт
100%	-5	63.1	11.51	74.1	12.53	88.7	13.82	90.0	16.22	97.6	15.85	112.2	17.55	115.6	19.35
	-2	63.1	11.67	74.1	12.70	88.7	14.10	90.0	16.35	97.6	16.07	112.2	17.77	115.6	19.48
	0	63.1	11.80	74.1	12.86	88.7	14.34	90.0	16.60	97.6	16.23	112.2	18.09	115.6	19.70
	2	63.1	11.97	74.1	13.02	88.7	14.66	90.0	16.75	97.6	16.42	112.2	18.38	115.6	20.02
	4	63.1	12.08	74.1	13.24	88.7	14.85	90.0	17.00	97.6	16.65	112.2	18.58	115.6	20.25
	6	63.1	12.34	74.1	13.43	88.7	15.11	90.0	17.36	97.6	16.91	112.2	18.87	115.6	20.57
	8	63.1	12.53	74.1	13.72	88.7	15.39	90.0	17.67	97.6	17.19	112.2	19.19	115.6	20.92
	10	63.1	12.79	74.1	13.97	88.7	15.63	90.0	17.95	97.6	17.53	112.2	19.53	115.6	21.23
	12	63.1	13.05	74.1	14.27	88.7	16.22	90.0	18.31	97.6	17.88	112.2	19.92	114.0	21.40
	14	63.1	13.31	74.1	14.58	88.7	16.98	90.0	19.47	97.6	18.22	112.2	20.35	112.7	21.67
	16	63.1	13.56	74.1	14.92	88.7	17.39	90.0	19.96	97.6	18.62	108.8	20.61	111.1	21.93
	18	63.1	13.82	74.1	15.22	88.7	18.06	90.0	20.75	97.6	19.00	107.6	21.35	109.8	22.49
	20	63.1	14.13	74.1	15.75	88.7	19.57	90.0	22.16	97.6	20.43	105.9	22.43	108.2	23.61
	21	63.1	14.26	74.1	16.39	88.7	20.96	90.0	23.51	97.6	21.17	105.3	23.00	107.6	24.18
	23	63.1	15.25	74.1	17.69	88.7	22.55	90.0	25.13	97.6	22.77	104.0	24.12	105.9	25.30
	25	63.1	16.34	74.1	19.08	88.7	24.33	90.0	26.39	97.6	24.46	102.4	25.25	104.7	26.43
	27	63.1	17.46	74.1	20.51	88.7	25.76	90.0	27.97	97.6	26.24	100.8	26.37	103.1	27.60
	29	63.1	18.68	74.1	22.03	88.7	27.70	90.0	28.80	97.3	27.93	99.5	28.51	101.8	28.72
	31	63.1	19.98	74.1	23.63	88.7	29.62	90.0	29.33	96.0	29.05	97.9	29.53	100.2	29.89
	33	63.1	21.32	74.1	25.32	88.7	31.03	90.0	30.16	94.4	30.18	96.6	30.62	98.9	31.06
	35	63.1	22.70	74.1	27.14	88.7	31.66	90.0	32.14	92.8	32.19	95.0	32.51	97.3	32.83
	37	63.1	24.22	74.1	29.04	88.7	31.89	88.8	33.60	91.8	34.08	93.7	34.51	95.7	34.97
	39	63.1	25.78	74.1	31.03	88.7	32.46	87.7	34.91	90.6	35.50	92.1	36.21	94.4	36.50
	41	63.1	26.74	74.1	32.24	88.7	32.95	86.6	36.16	89.3	36.90	88.8	37.25	93.0	37.65
43	63.1	27.71	74.1	32.87	88.7	34.04	86.3	37.88	88.1	38.48	89.3	39.14	89.6	39.44	
45	63.1	28.99	74.1	33.79	88.7	36.18	85.7	40.28	86.8	42.51	88.5	44.64	88.2	45.50	
48	63.1	33.43	74.1	36.00	88.7	38.57	84.7	43.39	85.6	45.96	86.5	48.53	86.9	51.11	
50	63.1	37.86	74.1	40.44	88.7	43.01	84.0	45.58	84.3	48.15	85.2	50.72	85.6	53.29	
52	63.1	42.30	74.1	44.87	88.7	47.44	83.2	50.01	83.1	52.58	83.9	55.16	84.2	57.73	
54	63.1	46.73	74.1	49.31	88.7	51.88	82.4	54.45	81.8	57.02	82.5	59.59	82.9	62.16	
75%	-5	45.6	6.75	54.6	6.97	63.3	8.10	67.8	9.35	73.6	10.06	83.6	11.57	89.9	13.25
	-2	45.6	6.84	54.6	7.05	63.3	8.22	67.8	9.40	73.6	10.19	83.6	11.69	89.9	13.38
	0	45.6	6.92	54.6	7.14	63.3	8.35	67.8	9.45	73.6	10.32	83.6	11.82	89.9	13.48
	2	45.6	7.02	54.6	7.24	63.3	8.44	67.8	9.71	73.6	10.48	83.6	12.06	89.9	13.68
	4	45.6	7.09	54.6	7.35	63.3	8.59	67.8	9.86	73.6	10.61	83.6	12.25	89.9	13.88
	6	45.6	7.24	54.6	7.50	63.3	8.76	67.8	10.05	73.6	10.80	83.6	12.44	89.9	14.12
	8	45.6	7.35	54.6	7.65	63.3	8.95	67.8	10.22	73.6	10.99	83.6	12.67	89.9	14.25
	10	45.6	7.50	54.6	7.83	63.3	9.13	67.8	10.40	73.6	11.24	83.6	12.83	89.9	14.48
	12	45.6	7.65	54.6	7.98	63.3	9.30	67.8	10.59	73.6	11.45	83.6	13.08	89.9	14.74
	14	45.6	7.80	54.6	8.12	63.3	9.48	67.8	10.93	73.6	11.65	83.6	13.32	89.9	15.01
	16	45.6	7.95	54.6	8.27	63.3	9.69	67.8	10.97	73.6	11.89	83.6	13.58	89.9	15.28
	18	45.6	8.11	54.6	8.45	63.3	9.87	67.8	11.00	73.6	12.13	83.6	13.85	89.9	15.76
	20	45.6	8.29	54.6	8.65	63.3	10.08	67.8	11.72	73.6	12.57	83.6	14.89	89.9	16.50
	21	45.6	8.36	54.6	8.72	63.3	10.25	67.8	12.55	73.6	13.02	83.6	15.43	89.9	16.88
	23	45.6	8.94	54.6	9.08	63.3	11.03	67.8	13.23	73.6	13.97	83.6	16.56	89.9	17.66
	25	45.6	9.58	54.6	9.73	63.3	11.83	67.8	14.21	73.6	14.92	83.6	17.72	89.9	18.43
	27	45.6	10.24	54.6	10.38	63.3	12.66	67.8	15.23	73.6	15.96	83.6	18.97	89.9	19.20
	29	45.6	10.95	54.6	11.10	63.3	13.55	67.8	15.94	73.6	17.06	83.6	19.83	89.9	19.98
	31	45.6	11.71	54.6	11.84	63.3	14.48	67.8	16.99	73.6	18.19	83.6	20.60	89.9	20.78
	33	45.6	12.50	54.6	12.61	63.3	15.49	67.8	18.02	73.6	19.41	83.6	21.40	89.9	21.55
	35	45.6	13.31	54.6	13.45	63.3	16.53	67.8	18.85	73.6	20.69	83.6	22.18	89.9	22.35
	37	45.6	14.20	54.6	14.31	63.3	17.63	67.8	19.70	73.6	22.06	83.6	22.95	89.9	23.13
	39	45.6	15.12	54.6	15.26	63.3	18.79	67.8	20.47	73.6	23.52	83.6	23.75	89.9	23.93
	41	45.6	15.68	54.6	15.97	63.3	19.49	67.8	21.20	73.6	23.63	83.6	24.36	89.9	24.50
43	45.6	16.25	54.6	16.67	63.3	20.20	67.8	22.21	73.6	24.13	83.6	24.67	89.9	24.88	
45	45.6	17.00	54.6	17.52	63.3	21.05	67.8	23.62	73.6	24.80	83.6	26.82	89.9	27.96	
48	45.6	19.60	54.6	21.49	63.3	23.37	67.8	25.26	73.6	27.14	83.6	29.03	89.9	30.91	
50	45.6	22.20	54.6	24.09	63.3	25.97	67.8	27.86	73.6	29.74	83.6	31.63	89.9	33.51	
52	45.6	24.80	54.6	26.69	63.3	28.57	67.8	30.46	73.6	32.34	83.6	34.23	89.9	36.11	
54	45.6	27.41	54.6	29.29	63.3	31.17	67.8	33.06	73.6	34.94	83.6	36.83	89.9	38.71	

Обозначения:

ТС: Полная производительность (кВт)

PI: Потребляемая мощность (компрессор + двигатель вентилятора наружного блока) (кВт)

Продолжение таблицы на следующей странице...

Таблица 2-8.24: Частичная холодильная нагрузка для блоков производительностью 32 л.с. (продолжение)

Частичная нагрузка	Температура наружного воздуха (°CDB)	Температура в помещении (°C DB/WD)													
		20.8/14		23.3/16		25.8/18		27/19		28.2/20		30.7/22		32/24	
		ТС	PI	ТС	PI	ТС	PI	ТС	PI	ТС	PI	ТС	PI	ТС	PI
		кВт	кВт	кВт	кВт	кВт	кВт	кВт	кВт	кВт	кВт	кВт	кВт	кВт	кВт
50%	-5	30.6	3.78	36.5	4.12	42.5	4.54	45.5	5.81	49.3	6.33	56.2	7.04	60.3	8.07
	-2	30.6	3.83	36.5	4.17	42.5	4.60	45.5	5.89	49.3	6.44	56.2	7.15	60.3	8.13
	0	30.6	3.87	36.5	4.22	42.5	4.68	45.5	5.96	49.3	6.52	56.2	7.25	60.3	8.23
	2	30.6	3.93	36.5	4.27	42.5	4.73	45.5	6.08	49.3	6.62	56.2	7.40	60.3	8.34
	4	30.6	3.97	36.5	4.35	42.5	4.81	45.5	6.15	49.3	6.76	56.2	7.52	60.3	8.46
	6	30.6	4.05	36.5	4.41	42.5	4.91	45.5	6.29	49.3	6.89	56.2	7.67	60.3	8.65
	8	30.6	4.12	36.5	4.50	42.5	5.01	45.5	6.41	49.3	7.03	56.2	7.81	60.3	8.79
	10	30.6	4.20	36.5	4.59	42.5	5.11	45.5	6.59	49.3	7.14	56.2	7.96	60.3	8.78
	12	30.6	4.28	36.5	4.69	42.5	5.21	45.5	6.71	49.3	7.29	56.2	8.11	60.3	8.92
	14	30.6	4.37	36.5	4.79	42.5	5.31	45.5	6.82	49.3	7.41	56.2	8.25	60.3	9.07
	16	30.6	4.45	36.5	4.90	42.5	5.43	45.5	6.94	49.3	7.55	56.2	8.40	60.3	9.24
	18	30.6	4.54	36.5	5.00	42.5	5.53	45.5	7.06	49.3	7.70	56.2	8.54	60.3	9.42
	20	30.6	4.64	36.5	5.17	42.5	5.64	45.5	7.20	49.3	7.76	56.2	8.72	60.3	9.59
	21	30.6	4.68	36.5	5.38	42.5	5.74	45.5	7.72	49.3	7.90	56.2	8.81	60.3	9.80
	23	30.6	5.01	36.5	5.81	42.5	6.18	45.5	8.25	49.3	8.40	56.2	9.16	60.3	9.88
	25	30.6	5.36	36.5	6.27	42.5	6.63	45.5	8.70	49.3	8.95	56.2	9.77	60.3	10.53
	27	30.6	5.73	36.5	6.74	42.5	7.09	45.5	9.13	49.3	9.53	56.2	10.41	60.3	11.23
	29	30.6	6.13	36.5	7.23	42.5	7.59	45.5	9.52	49.3	10.15	56.2	11.11	60.3	11.98
	31	30.6	6.56	36.5	7.76	42.5	8.11	45.5	10.04	49.3	10.79	56.2	11.81	60.3	12.80
	33	30.6	7.00	36.5	8.31	42.5	8.67	45.5	10.47	49.3	11.46	56.2	12.57	60.3	13.62
	35	30.6	7.46	36.5	8.91	42.5	9.26	45.5	10.55	49.3	12.16	56.2	13.38	60.3	14.52
	37	30.6	7.95	36.5	9.54	42.5	9.87	45.5	11.04	49.3	12.92	56.2	14.23	60.3	15.45
	39	30.6	8.47	36.5	10.19	42.5	10.52	45.5	11.46	49.3	13.39	56.2	15.10	60.3	16.44
	41	30.6	8.78	36.5	10.59	42.5	10.92	45.5	11.88	49.3	13.86	56.2	15.82	60.3	17.49
43	30.6	9.10	36.5	10.80	42.5	11.31	45.5	12.44	49.3	14.55	56.2	16.49	60.3	18.29	
45	30.6	9.84	36.5	12.15	42.5	12.84	45.5	13.54	49.3	15.72	56.2	17.23	60.3	19.08	
48	30.6	11.29	36.5	12.67	42.5	14.04	45.5	15.41	49.3	16.78	56.2	18.16	60.3	19.53	
50	30.6	12.75	36.5	14.12	42.5	15.50	45.5	16.87	49.3	18.24	56.2	19.61	60.3	20.98	
52	30.6	14.21	36.5	15.58	42.5	16.95	45.5	18.32	49.3	19.70	56.2	21.07	60.3	22.44	
54	30.6	15.66	36.5	17.04	42.5	18.41	45.5	19.78	49.3	21.15	56.2	22.52	60.3	23.90	
25%	-5	15.3	2.05	18.3	2.24	21.2	2.47	22.6	3.38	24.5	3.51	27.9	3.99	30.1	4.30
	-2	15.3	2.08	18.3	2.26	21.2	2.50	22.6	3.47	24.5	3.57	27.9	4.04	30.1	4.36
	0	15.3	2.10	18.3	2.29	21.2	2.54	22.6	3.48	24.5	3.61	27.9	4.11	30.1	4.43
	2	15.3	2.13	18.3	2.32	21.2	2.57	22.6	3.49	24.5	3.68	27.9	4.13	30.1	4.52
	4	15.3	2.16	18.3	2.36	21.2	2.61	22.6	3.50	24.5	3.75	27.9	4.23	30.1	4.63
	6	15.3	2.20	18.3	2.40	21.2	2.67	22.6	3.53	24.5	3.82	27.9	4.30	30.1	4.77
	8	15.3	2.24	18.3	2.45	21.2	2.72	22.6	3.54	24.5	3.87	27.9	4.37	30.1	4.92
	10	15.3	2.28	18.3	2.49	21.2	2.78	22.6	3.51	24.5	3.98	27.9	4.48	30.1	5.00
	12	15.3	2.33	18.3	2.55	21.2	2.83	22.6	3.53	24.5	4.06	27.9	4.56	30.1	5.08
	14	15.3	2.37	18.3	2.60	21.2	2.88	22.6	3.55	24.5	4.12	27.9	4.64	30.1	5.18
	16	15.3	2.42	18.3	2.66	21.2	2.95	22.6	3.56	24.5	4.18	27.9	4.72	30.1	5.26
	18	15.3	2.47	18.3	2.72	21.2	3.00	22.6	3.57	24.5	4.26	27.9	4.80	30.1	5.36
	20	15.3	2.52	18.3	2.81	21.2	3.07	22.6	3.74	24.5	4.34	27.9	4.88	30.1	5.46
	21	15.3	2.54	18.3	2.92	21.2	3.12	22.6	3.93	24.5	4.38	27.9	4.94	30.1	5.51
	23	15.3	2.72	18.3	3.16	21.2	3.35	22.6	4.19	24.5	4.46	27.9	5.02	30.1	5.63
	25	15.3	2.91	18.3	3.40	21.2	3.60	22.6	4.46	24.5	4.60	27.9	5.28	30.1	6.01
	27	15.3	3.12	18.3	3.66	21.2	3.85	22.6	4.81	24.5	4.88	27.9	5.61	30.1	6.41
	29	15.3	3.33	18.3	3.93	21.2	4.12	22.6	4.96	24.5	5.20	27.9	5.97	30.1	6.83
	31	15.3	3.56	18.3	4.21	21.2	4.40	22.6	5.28	24.5	5.51	27.9	6.35	30.1	7.27
	33	15.3	3.80	18.3	4.52	21.2	4.71	22.6	5.57	24.5	5.85	27.9	6.75	30.1	7.72
	35	15.3	4.05	18.3	4.84	21.2	5.03	22.6	5.73	24.5	6.19	27.9	7.17	30.1	8.20
	37	15.3	4.32	18.3	5.18	21.2	5.36	22.6	5.99	24.5	6.57	27.9	7.61	30.1	8.72
	39	15.3	4.60	18.3	5.54	21.2	5.72	22.6	6.23	24.5	6.97	27.9	8.06	30.1	9.26
	41	15.3	4.77	18.3	5.75	21.2	5.93	22.6	6.45	24.5	7.27	27.9	8.49	30.1	9.69
43	15.3	4.94	18.3	5.86	21.2	6.15	22.6	6.87	24.5	7.46	27.9	8.92	30.1	10.12	
45	15.3	5.17	18.3	6.60	21.2	7.03	22.6	7.59	24.5	8.33	27.9	9.78	30.1	10.55	
48	15.3	6.08	18.3	6.94	21.2	7.80	22.6	8.66	24.5	9.52	27.9	10.38	30.1	11.24	
50	15.3	6.98	18.3	7.84	21.2	8.70	22.6	9.56	24.5	10.42	27.9	11.28	30.1	12.14	
52	15.3	7.89	18.3	8.75	21.2	9.61	22.6	10.47	24.5	11.33	27.9	12.19	30.1	13.05	
54	15.3	8.80	18.3	9.66	21.2	10.52	22.6	11.38	24.5	12.24	27.9	13.10	30.1	13.96	

Обозначения:

ТС: Полная производительность (кВт)

PI: Потребляемая мощность (компрессор + двигатель вентилятора наружного блока) (кВт)

8.6 Частичная тепловая нагрузка при комбинационном соотношении 100%

Таблица 2-8.25: Частичная тепловая нагрузка для блоков производительностью 18 л.с.

Частичная нагрузка	Температура наружного воздуха (°CDB)		Температура в помещении (°C DB/WD)											
			16.0		18.0		20.0		21.0		22.0		24.0	
	°C DB	°C WB	ТС	PI	ТС	PI	ТС	PI	ТС	PI	ТС	PI	ТС	PI
100%	-25	-25.4	40.63	14.50	40.48	14.64	40.32	14.80	40.32	14.89	40.32	14.98	40.16	15.17
	-19.8	-20	40.95	14.50	40.79	14.66	40.63	14.82	40.63	14.91	40.63	14.99	40.48	15.17
	-18.8	-19	41.59	14.53	41.43	14.69	41.27	14.85	41.27	14.92	41.27	15.01	41.11	15.19
	-16.7	-17	42.22	14.55	42.06	14.71	42.06	14.87	41.90	14.96	41.90	15.05	41.75	14.87
	-13.7	-15	42.86	14.59	42.70	14.73	42.70	14.91	42.54	14.98	42.54	15.06	42.38	14.57
	-11.8	-13	43.49	14.60	43.33	14.76	43.33	14.92	43.17	15.01	43.17	15.08	42.38	14.29
	-9.8	-11	43.81	14.62	43.81	14.78	43.65	14.94	43.65	15.01	43.49	15.10	42.38	14.14
	-9.5	-10	44.13	14.64	43.97	14.78	43.97	14.94	43.81	15.03	43.81	15.12	42.38	14.02
	-8.5	-9.1	44.60	14.66	44.60	14.80	44.44	14.96	44.29	15.05	44.29	15.14	42.38	13.83
	-7	-7.6	48.10	14.68	47.94	14.81	47.94	14.96	47.78	15.59	46.19	14.83	42.38	13.38
	-5	-5.6	48.73	14.69	48.57	14.81	48.57	14.97	48.10	16.13	46.19	15.35	42.38	13.84
	-3	-3.7	49.68	14.71	49.52	14.82	49.52	14.48	48.10	15.17	46.19	16.13	42.38	14.55
	0	-0.7	50.95	14.73	53.81	14.83	50.00	14.08	48.10	15.95	46.19	15.21	42.38	13.67
	3	2.2	54.29	15.65	53.81	14.46	50.00	13.67	48.10	14.68	46.19	14.00	42.38	12.66
	5	4.1	57.62	14.84	53.81	13.76	50.00	13.03	48.10	13.40	46.19	12.80	42.38	11.65
	7	6	57.62	14.03	53.81	13.05	50.00	12.20	48.10	11.72	46.19	11.23	42.38	10.29
	9	7.9	57.62	13.23	53.81	12.36	50.00	11.49	48.10	11.07	46.19	10.64	42.38	9.81
11	9.8	57.62	12.38	53.81	11.60	50.00	10.86	48.10	10.48	46.19	10.11	42.38	9.39	
13	11.8	57.62	11.60	53.81	10.94	50.00	10.29	48.10	9.97	46.19	9.65	42.38	9.02	
15	13.7	57.62	11.03	53.81	10.47	50.00	9.88	48.10	9.60	46.19	9.32	42.38	8.75	
75%	-25	-25.4	42.84	15.82	40.22	14.55	37.51	13.33	35.98	12.73	34.62	12.15	31.74	10.99
	-19.8	-20	42.77	15.49	40.22	14.25	37.51	13.07	35.98	12.48	34.62	11.90	31.74	10.77
	-18.8	-19	43.11	15.33	40.22	14.11	37.51	12.92	35.98	12.35	34.62	11.79	31.74	10.68
	-16.7	-17	43.11	15.01	40.22	13.83	37.51	12.68	35.98	12.11	34.62	11.55	31.74	10.48
	-13.7	-15	43.11	14.72	40.22	13.55	37.51	12.42	35.98	11.88	34.62	11.33	31.74	10.27
	-11.8	-13	43.11	14.42	40.22	13.29	37.51	12.20	35.98	11.64	34.62	11.13	31.74	10.09
	-9.8	-11	43.11	14.14	40.22	13.03	37.51	11.96	35.98	11.44	34.62	10.92	31.74	9.90
	-9.5	-10	43.11	14.01	40.22	12.92	37.51	11.85	35.98	11.33	34.62	10.81	31.74	9.83
	-8.5	-9.1	43.11	13.88	40.22	12.81	37.51	11.75	35.98	11.24	34.62	10.74	31.74	9.74
	-7	-7.6	43.11	13.70	40.22	12.62	37.51	11.59	35.98	11.09	34.62	10.59	31.74	9.61
	-5	-5.6	43.11	13.27	40.22	12.25	37.51	11.27	35.98	10.79	34.62	10.31	31.74	9.39
	-3	-3.7	43.11	13.74	40.22	12.68	37.51	11.66	35.98	11.16	34.62	10.68	31.74	9.72
	0	-0.7	43.11	14.44	40.22	13.35	37.51	12.27	35.98	11.75	34.62	11.24	31.74	10.24
	3	2.2	43.11	12.57	40.22	11.64	37.51	10.74	35.98	10.29	34.62	9.85	31.74	9.00
	5	4.1	43.11	11.61	40.22	10.81	37.51	10.01	35.98	9.63	34.62	9.24	31.74	8.48
	7	6	43.11	10.29	40.22	9.63	37.51	8.98	35.98	8.64	34.62	8.33	31.74	7.70
	9	7.9	43.11	9.85	40.22	9.26	37.51	8.68	35.98	10.26	34.62	8.11	31.74	7.55
11	9.8	43.11	9.46	40.22	8.94	37.51	8.42	35.98	8.18	34.62	7.92	31.74	7.42	
13	11.8	43.11	9.11	40.22	8.66	37.51	8.20	35.98	7.98	34.62	7.76	31.74	7.31	
15	13.7	43.11	8.87	40.22	8.46	37.51	8.07	35.98	7.87	34.62	7.66	31.74	7.27	

Обозначения:

ТС: Полная производительность (кВт)

PI: Потребляемая мощность (компрессор + двигатель вентилятора наружного блока) (кВт)

Продолжение таблицы на следующей странице...

Таблица 2-8.25: Частичная тепловая нагрузка для блоков производительностью 18 л.с. (продолжение)

Частичная нагрузка	Температура наружного воздуха (°CDB)		Температура в помещении (°C DB/WD)											
			16.0		18.0		20.0		21.0		22.0		24.0	
	°C DB	°C WB	ТС	PI	ТС	PI	ТС	PI	ТС	PI	ТС	PI	ТС	PI
50%	-25	-25.4	28.89	9.66	26.98	8.95	25.08	8.25	23.97	8.64	23.02	7.58	21.11	6.93
	-19.8	-20	28.89	9.49	26.98	8.80	25.08	8.11	23.97	7.79	23.02	7.45	21.11	6.82
	-18.8	-19	28.89	9.40	26.98	8.71	25.08	8.04	23.97	9.38	23.02	7.39	21.11	6.75
	-16.7	-17	28.89	9.22	26.98	8.55	25.08	7.89	23.97	7.57	23.02	7.25	21.11	6.63
	-13.7	-15	28.89	9.05	26.98	8.39	25.08	7.76	23.97	7.44	23.02	7.14	21.11	6.51
	-11.8	-13	28.89	8.88	26.98	8.24	25.08	7.62	23.97	7.30	23.02	7.00	21.11	6.41
	-9.8	-11	28.89	8.73	26.98	8.11	25.08	7.49	23.97	7.19	23.02	6.88	21.11	6.30
	-9.5	-10	28.89	8.65	26.98	8.03	25.08	7.42	23.97	7.12	23.02	6.83	21.11	6.25
	-8.5	-9.1	28.89	8.58	26.98	7.97	25.08	7.37	23.97	7.07	23.02	6.78	21.11	6.21
	-7	-7.6	28.89	8.48	26.98	7.87	25.08	7.27	23.97	6.98	23.02	6.70	21.11	6.13
	-5	-5.6	28.89	8.28	26.98	7.69	25.08	7.12	23.97	6.85	23.02	6.56	21.11	6.03
	-3	-3.7	28.89	8.58	26.98	7.97	25.08	7.39	23.97	7.10	23.02	6.82	21.11	6.25
	0	-0.7	28.89	9.03	26.98	8.39	25.08	7.79	23.97	7.49	23.02	7.19	21.11	6.60
	3	2.2	28.89	7.94	26.98	7.40	25.08	6.87	23.97	6.61	23.02	6.35	21.11	5.84
	5	4.1	28.89	7.50	26.98	7.02	25.08	6.56	23.97	6.33	23.02	6.09	21.11	5.64
	7	6	28.89	6.82	26.98	6.43	25.08	6.03	23.97	5.84	23.02	5.64	21.11	5.25
	9	7.9	28.89	6.70	26.98	6.35	25.08	5.99	23.97	5.83	23.02	5.64	21.11	5.31
11	9.8	28.89	6.60	26.98	6.28	25.08	5.96	23.97	5.81	23.02	5.66	21.11	5.34	
13	11.8	28.89	6.51	26.98	6.23	25.08	5.96	23.97	5.81	23.02	5.66	21.11	5.41	
15	13.7	28.89	6.50	26.98	6.23	25.08	5.98	23.97	5.86	23.02	5.74	21.11	5.49	
25%	-25	-25.4	14.42	5.22	13.49	4.81	12.50	4.42	12.04	4.23	11.51	4.04	10.58	3.67
	-19.8	-20	14.42	5.11	13.49	4.72	12.50	4.33	12.04	4.14	11.51	3.96	10.58	3.60
	-18.8	-19	14.42	5.06	13.49	4.67	12.50	4.29	12.04	4.11	11.51	3.92	10.58	3.57
	-16.7	-17	14.42	4.96	13.49	4.58	12.50	4.21	12.04	4.03	11.51	3.85	10.58	3.51
	-13.7	-15	14.42	4.86	13.49	4.49	12.50	4.13	12.04	3.95	11.51	3.78	10.58	3.44
	-11.8	-13	14.42	4.77	13.49	4.41	12.50	4.06	12.04	3.88	11.51	3.71	10.58	3.38
	-9.8	-11	14.42	4.68	13.49	4.33	12.50	3.98	12.04	3.81	11.51	3.65	10.58	3.32
	-9.5	-10	14.42	4.64	13.49	4.28	12.50	3.95	12.04	3.78	11.51	3.62	10.58	3.29
	-8.5	-9.1	14.42	4.60	13.49	4.25	12.50	3.92	12.04	3.75	11.51	3.59	10.58	3.27
	-7	-7.6	14.42	4.53	13.49	4.20	12.50	3.87	12.04	3.70	11.51	3.54	10.58	3.23
	-5	-5.6	14.42	4.41	13.49	4.09	12.50	3.77	12.04	3.62	11.51	3.46	10.58	3.16
	-3	-3.7	14.42	4.57	13.49	4.23	12.50	3.90	12.04	3.75	11.51	3.59	10.58	3.28
	0	-0.7	14.42	4.80	13.49	4.45	12.50	4.11	12.04	3.95	11.51	3.78	10.58	3.45
	3	2.2	14.42	4.20	13.49	3.90	12.50	3.61	12.04	3.47	11.51	3.32	10.58	3.04
	5	4.1	14.42	3.92	13.49	3.66	12.50	3.40	12.04	3.28	11.51	3.15	10.58	2.90
	7	6	14.42	3.52	13.49	3.30	12.50	3.09	12.04	2.98	11.51	2.88	10.58	2.67
	9	7.9	14.42	3.41	13.49	3.21	12.50	3.02	12.04	2.93	11.51	2.84	10.58	2.65
11	9.8	14.42	3.31	13.49	3.14	12.50	2.97	12.04	2.88	11.51	2.80	10.58	2.63	
13	11.8	14.42	3.23	13.49	3.07	12.50	2.93	12.04	2.85	11.51	2.77	10.58	2.63	
15	13.7	14.42	3.18	13.49	3.04	12.50	2.90	12.04	2.84	11.51	2.77	10.58	2.63	

Обозначения:

ТС: Полная производительность (кВт)

PI: Потребляемая мощность (компрессор + двигатель вентилятора наружного блока) (кВт)

MVS FDC II-S

Таблица 2-8.26: Частичная тепловая нагрузка для блоков производительностью 20 л.с.

Частичная нагрузка	Температура наружного воздуха (°CDB)		Температура в помещении (°C DB/WD)											
			16.0		18.0		20.0		21.0		22.0		24.0	
	°C DB	°C WB	ТС	PI	ТС	PI	ТС	PI	ТС	PI	ТС	PI	ТС	PI
100%	-25	-25.4	45.51	16.42	45.33	16.58	45.16	16.76	45.16	16.86	45.16	16.96	44.98	17.18
	-19.8	-20	45.87	16.42	45.69	16.60	45.51	16.78	45.51	16.88	45.51	16.98	45.33	17.18
	-18.8	-19	46.58	16.46	46.40	16.64	46.22	16.82	46.22	16.90	46.22	17.00	46.04	17.20
	-16.7	-17	47.29	16.48	47.11	16.66	47.11	16.84	46.93	16.94	46.93	17.04	46.76	16.84
	-13.7	-15	48.00	16.52	47.82	16.68	47.82	16.88	47.64	16.96	47.64	17.06	47.47	16.50
	-11.8	-13	48.71	16.54	48.53	16.72	48.53	16.90	48.36	17.00	48.36	17.08	47.47	16.18
	-9.8	-11	49.07	16.56	49.07	16.74	48.89	16.92	48.89	17.00	48.71	17.10	47.47	16.02
	-9.5	-10	49.42	16.58	49.24	16.74	49.24	16.92	49.07	17.02	49.07	17.12	47.47	15.88
	-8.5	-9.1	49.96	16.60	49.96	16.76	49.78	16.94	49.60	17.04	49.60	17.14	47.47	15.66
	-7	-7.6	53.87	16.62	53.69	16.77	53.69	16.95	53.51	17.67	51.73	16.80	47.47	15.16
	-5	-5.6	54.58	16.64	54.40	16.78	54.40	16.96	53.87	18.27	51.73	17.39	47.47	15.68
	-3	-3.7	55.64	16.66	55.47	16.79	55.47	16.40	53.87	17.18	51.73	18.27	47.47	16.48
	0	-0.7	57.07	16.68	60.27	16.80	56.00	15.95	53.87	18.07	51.73	17.22	47.47	15.48
	3	2.2	60.80	17.73	60.27	16.38	56.00	15.49	53.87	16.62	51.73	15.86	47.47	14.34
	5	4.1	64.53	16.81	60.27	15.58	56.00	14.76	53.87	15.18	51.73	14.50	47.47	13.20
	7	6	64.53	15.89	60.27	14.78	56.00	13.82	53.87	13.28	51.73	12.72	47.47	11.66
	9	7.9	64.53	14.98	60.27	14.00	56.00	13.02	53.87	12.54	51.73	12.06	47.47	11.12
11	9.8	64.53	14.02	60.27	13.14	56.00	12.30	53.87	11.88	51.73	11.46	47.47	10.64	
13	11.8	64.53	13.14	60.27	12.40	56.00	11.66	53.87	11.30	51.73	10.94	47.47	10.21	
15	13.7	64.53	12.50	60.27	11.86	56.00	11.20	53.87	10.88	51.73	10.56	47.47	9.91	
75%	-25	-25.4	47.98	17.92	45.05	16.48	42.01	15.10	40.30	14.42	38.78	13.76	35.55	12.45
	-19.8	-20	47.90	17.55	45.05	16.15	42.01	14.80	40.30	14.13	38.78	13.48	35.55	12.20
	-18.8	-19	48.28	17.36	45.05	15.98	42.01	14.64	40.30	13.99	38.78	13.36	35.55	12.10
	-16.7	-17	48.28	17.01	45.05	15.66	42.01	14.36	40.30	13.71	38.78	13.08	35.55	11.87
	-13.7	-15	48.28	16.67	45.05	15.35	42.01	14.07	40.30	13.46	38.78	12.83	35.55	11.64
	-11.8	-13	48.28	16.34	45.05	15.06	42.01	13.82	40.30	13.19	38.78	12.60	35.55	11.43
	-9.8	-11	48.28	16.02	45.05	14.76	42.01	13.55	40.30	12.96	38.78	12.37	35.55	11.22
	-9.5	-10	48.28	15.87	45.05	14.64	42.01	13.42	40.30	12.83	38.78	12.25	35.55	11.13
	-8.5	-9.1	48.28	15.73	45.05	14.51	42.01	13.32	40.30	12.73	38.78	12.16	35.55	11.03
	-7	-7.6	48.28	15.52	45.05	14.30	42.01	13.13	40.30	12.56	38.78	11.99	35.55	10.88
	-5	-5.6	48.28	15.03	45.05	13.88	42.01	12.77	40.30	12.23	38.78	11.68	35.55	10.63
	-3	-3.7	48.28	15.56	45.05	14.36	42.01	13.21	40.30	12.64	38.78	12.10	35.55	11.01
	0	-0.7	48.28	16.36	45.05	15.12	42.01	13.90	40.30	13.32	38.78	12.73	35.55	11.60
	3	2.2	48.28	14.24	45.05	13.19	42.01	12.16	40.30	11.66	38.78	11.16	35.55	10.19
	5	4.1	48.28	13.15	45.05	12.25	42.01	11.34	40.30	10.90	38.78	10.46	35.55	9.60
	7	6	48.28	11.66	45.05	10.90	42.01	10.17	40.30	9.79	38.78	9.44	35.55	8.72
	9	7.9	48.28	11.16	45.05	10.48	42.01	9.83	40.30	11.62	38.78	9.18	35.55	8.56
11	9.8	48.28	10.72	45.05	10.13	42.01	9.54	40.30	9.27	38.78	8.97	35.55	8.41	
13	11.8	48.28	10.32	45.05	9.81	42.01	9.29	40.30	9.04	38.78	8.79	35.55	8.28	
15	13.7	48.28	10.04	45.05	9.58	42.01	9.14	40.30	8.91	38.78	8.68	35.55	8.24	

Обозначения:

ТС: Полная производительность (кВт)

PI: Потребляемая мощность (компрессор + двигатель вентилятора наружного блока) (кВт)

Продолжение таблицы на следующей странице...

Таблица 2-8.26: Частичная тепловая нагрузка для блоков производительностью 20 л.с. (продолжение)

Частичная нагрузка	Температура наружного воздуха (°CDB)		Температура в помещении (°C DB/WD)											
			16.0		18.0		20.0		21.0		22.0		24.0	
	°C DB	°C WB	ТС	PI	ТС	PI	ТС	PI	ТС	PI	ТС	PI	ТС	PI
50%	-25	-25.4	32.36	10.94	30.22	10.14	28.09	9.35	26.84	9.79	25.78	8.59	23.64	7.85
	-19.8	-20	32.36	10.75	30.22	9.97	28.09	9.19	26.84	8.82	25.78	8.44	23.64	7.72
	-18.8	-19	32.36	10.65	30.22	9.87	28.09	9.11	26.84	10.63	25.78	8.37	23.64	7.65
	-16.7	-17	32.36	10.44	30.22	9.68	28.09	8.94	26.84	8.58	25.78	8.22	23.64	7.51
	-13.7	-15	32.36	10.25	30.22	9.51	28.09	8.79	26.84	8.42	25.78	8.08	23.64	7.38
	-11.8	-13	32.36	10.06	30.22	9.34	28.09	8.63	26.84	8.27	25.78	7.93	23.64	7.26
	-9.8	-11	32.36	9.89	30.22	9.19	28.09	8.48	26.84	8.14	25.78	7.80	23.64	7.13
	-9.5	-10	32.36	9.79	30.22	9.09	28.09	8.41	26.84	8.06	25.78	7.74	23.64	7.07
	-8.5	-9.1	32.36	9.72	30.22	9.03	28.09	8.35	26.84	8.01	25.78	7.68	23.64	7.04
	-7	-7.6	32.36	9.60	30.22	8.92	28.09	8.23	26.84	7.91	25.78	7.59	23.64	6.94
	-5	-5.6	32.36	9.38	30.22	8.71	28.09	8.06	26.84	7.76	25.78	7.44	23.64	6.83
	-3	-3.7	32.36	9.72	30.22	9.03	28.09	8.37	26.84	8.04	25.78	7.72	23.64	7.07
	0	-0.7	32.36	10.23	30.22	9.51	28.09	8.82	26.84	8.48	25.78	8.14	23.64	7.47
	3	2.2	32.36	9.00	30.22	8.39	28.09	7.78	26.84	7.49	25.78	7.19	23.64	6.62
	5	4.1	32.36	8.50	30.22	7.95	28.09	7.44	26.84	7.17	25.78	6.90	23.64	6.39
	7	6	32.36	7.72	30.22	7.28	28.09	6.83	26.84	6.62	25.78	6.39	23.64	5.95
9	7.9	32.36	7.59	30.22	7.19	28.09	6.79	26.84	6.60	25.78	6.39	23.64	6.01	
11	9.8	32.36	7.47	30.22	7.11	28.09	6.75	26.84	6.58	25.78	6.41	23.64	6.05	
13	11.8	32.36	7.38	30.22	7.06	28.09	6.75	26.84	6.58	25.78	6.41	23.64	6.12	
15	13.7	32.36	7.36	30.22	7.06	28.09	6.77	26.84	6.64	25.78	6.50	23.64	6.22	
25%	-25	-25.4	16.15	5.91	15.11	5.45	14.00	5.01	13.48	4.79	12.89	4.58	11.85	4.16
	-19.8	-20	16.15	5.79	15.11	5.34	14.00	4.91	13.48	4.69	12.89	4.49	11.85	4.08
	-18.8	-19	16.15	5.73	15.11	5.29	14.00	4.86	13.48	4.65	12.89	4.45	11.85	4.05
	-16.7	-17	16.15	5.62	15.11	5.18	14.00	4.77	13.48	4.56	12.89	4.36	11.85	3.97
	-13.7	-15	16.15	5.51	15.11	5.08	14.00	4.68	13.48	4.48	12.89	4.29	11.85	3.90
	-11.8	-13	16.15	5.40	15.11	4.99	14.00	4.59	13.48	4.40	12.89	4.20	11.85	3.83
	-9.8	-11	16.15	5.30	15.11	4.90	14.00	4.51	13.48	4.32	12.89	4.13	11.85	3.76
	-9.5	-10	16.15	5.25	15.11	4.85	14.00	4.47	13.48	4.28	12.89	4.10	11.85	3.73
	-8.5	-9.1	16.15	5.22	15.11	4.82	14.00	4.44	13.48	4.25	12.89	4.06	11.85	3.71
	-7	-7.6	16.15	5.13	15.11	4.75	14.00	4.38	13.48	4.20	12.89	4.01	11.85	3.66
	-5	-5.6	16.15	4.99	15.11	4.63	14.00	4.27	13.48	4.10	12.89	3.92	11.85	3.58
	-3	-3.7	16.15	5.18	15.11	4.79	14.00	4.42	13.48	4.25	12.89	4.06	11.85	3.71
	0	-0.7	16.15	5.44	15.11	5.04	14.00	4.66	13.48	4.47	12.89	4.28	11.85	3.91
	3	2.2	16.15	4.76	15.11	4.42	14.00	4.09	13.48	3.93	12.89	3.76	11.85	3.45
	5	4.1	16.15	4.45	15.11	4.15	14.00	3.86	13.48	3.71	12.89	3.57	11.85	3.29
	7	6	16.15	3.99	15.11	3.74	14.00	3.50	13.48	3.37	12.89	3.26	11.85	3.02
9	7.9	16.15	3.86	15.11	3.64	14.00	3.42	13.48	3.32	12.89	3.22	11.85	3.00	
11	9.8	16.15	3.75	15.11	3.56	14.00	3.36	13.48	3.27	12.89	3.17	11.85	2.98	
13	11.8	16.15	3.66	15.11	3.48	14.00	3.32	13.48	3.22	12.89	3.14	11.85	2.97	
15	13.7	16.15	3.60	15.11	3.44	14.00	3.29	13.48	3.22	12.89	3.14	11.85	2.98	

Обозначения:

ТС: Полная производительность (кВт)

PI: Потребляемая мощность (компрессор + двигатель вентилятора наружного блока) (кВт)

MVS FDC II-S

Таблица 2-8.27: Частичная тепловая нагрузка для блоков производительностью 22 л.с.

Частичная нагрузка	Температура наружного воздуха (°CDB)		Температура в помещении (°C DB/WD)											
			16.0		18.0		20.0		21.0		22.0		24.0	
	°C DB	°C WB	ТС	PI	ТС	PI	ТС	PI	ТС	PI	ТС	PI	ТС	PI
100%	-25	-25.4	49.98	20.88	49.79	21.08	49.59	21.31	49.59	21.44	49.59	21.57	49.40	21.85
	-19.8	-20	50.37	20.88	50.18	21.11	49.98	21.34	49.98	21.47	49.98	21.59	49.79	21.85
	-18.8	-19	51.15	20.93	50.96	21.16	50.76	21.39	50.76	21.49	50.76	21.62	50.57	21.87
	-16.7	-17	51.93	20.96	51.74	21.19	51.74	21.42	51.54	21.54	51.54	21.67	51.35	21.42
	-13.7	-15	52.71	21.01	52.52	21.21	52.52	21.47	52.32	21.57	52.32	21.70	52.13	20.98
	-11.8	-13	53.50	21.03	53.30	21.26	53.30	21.49	53.10	21.62	53.10	21.72	52.13	20.57
	-9.8	-11	53.89	21.06	53.89	21.29	53.69	21.52	53.69	21.62	53.50	21.75	52.13	20.37
	-9.5	-10	54.28	21.08	54.08	21.29	54.08	21.52	53.89	21.64	53.89	21.77	52.13	20.19
	-8.5	-9.1	54.86	21.11	54.86	21.31	54.67	21.54	54.47	21.67	54.47	21.80	52.13	19.91
	-7	-7.6	59.16	21.13	58.96	21.32	58.96	21.55	58.77	22.46	56.81	21.36	52.13	19.28
	-5	-5.6	59.94	21.16	59.74	21.33	59.74	21.56	59.16	23.22	56.81	22.10	52.13	19.94
	-3	-3.7	61.11	21.19	60.91	21.35	60.91	20.85	59.16	21.85	56.81	23.22	52.13	20.96
	0	-0.7	62.67	21.21	66.19	21.36	61.50	20.27	59.16	22.97	56.81	21.90	52.13	19.68
	3	2.2	66.77	22.54	66.19	20.83	61.50	19.69	59.16	21.13	56.81	20.17	52.13	18.23
	5	4.1	70.87	21.37	66.19	19.81	61.50	18.76	59.16	19.30	56.81	18.44	52.13	16.78
	7	6	70.87	20.20	66.19	18.79	61.50	17.57	59.16	16.88	56.81	16.17	52.13	14.82
	9	7.9	70.87	19.05	66.19	17.80	61.50	16.55	59.16	15.94	56.81	15.33	52.13	14.13
11	9.8	70.87	17.82	66.19	16.70	61.50	15.63	59.16	15.10	56.81	14.57	52.13	13.52	
13	11.8	70.87	16.70	66.19	15.76	61.50	14.82	59.16	14.36	56.81	13.90	52.13	12.99	
15	13.7	70.87	15.89	66.19	15.07	61.50	14.23	59.16	13.83	56.81	13.42	52.13	12.60	
75%	-25	-25.4	52.69	22.79	49.47	20.95	46.13	19.20	44.26	18.33	42.59	17.49	39.04	15.83
	-19.8	-20	52.61	22.31	49.47	20.53	46.13	18.82	44.26	17.97	42.59	17.14	39.04	15.52
	-18.8	-19	53.02	22.07	49.47	20.31	46.13	18.61	44.26	17.78	42.59	16.98	39.04	15.38
	-16.7	-17	53.02	21.62	49.47	19.91	46.13	18.26	44.26	17.44	42.59	16.64	39.04	15.09
	-13.7	-15	53.02	21.19	49.47	19.51	46.13	17.89	44.26	17.12	42.59	16.32	39.04	14.80
	-11.8	-13	53.02	20.77	49.47	19.14	46.13	17.57	44.26	16.77	42.59	16.02	39.04	14.53
	-9.8	-11	53.02	20.37	49.47	18.77	46.13	17.22	44.26	16.48	42.59	15.73	39.04	14.26
	-9.5	-10	53.02	20.18	49.47	18.61	46.13	17.06	44.26	16.32	42.59	15.57	39.04	14.16
	-8.5	-9.1	53.02	19.99	49.47	18.45	46.13	16.93	44.26	16.18	42.59	15.46	39.04	14.02
	-7	-7.6	53.02	19.73	49.47	18.18	46.13	16.69	44.26	15.97	42.59	15.25	39.04	13.84
	-5	-5.6	53.02	19.11	49.47	17.65	46.13	16.24	44.26	15.54	42.59	14.85	39.04	13.52
	-3	-3.7	53.02	19.78	49.47	18.26	46.13	16.80	44.26	16.08	42.59	15.38	39.04	14.00
	0	-0.7	53.02	20.79	49.47	19.22	46.13	17.68	44.26	16.93	42.59	16.18	39.04	14.74
	3	2.2	53.02	18.10	49.47	16.77	46.13	15.46	44.26	14.82	42.59	14.18	39.04	12.96
	5	4.1	53.02	16.72	49.47	15.57	46.13	14.42	44.26	13.86	42.59	13.30	39.04	12.21
	7	6	53.02	14.82	49.47	13.86	46.13	12.93	44.26	12.45	42.59	12.00	39.04	11.09
	9	7.9	53.02	14.18	49.47	13.33	46.13	12.50	44.26	14.77	42.59	11.68	39.04	10.88
11	9.8	53.02	13.62	49.47	12.88	46.13	12.13	44.26	11.78	42.59	11.41	39.04	10.69	
13	11.8	53.02	13.12	49.47	12.48	46.13	11.81	44.26	11.49	42.59	11.17	39.04	10.53	
15	13.7	53.02	12.77	49.47	12.18	46.13	11.62	44.26	11.33	42.59	11.04	39.04	10.48	

Обозначения:

ТС: Полная производительность (кВт)

PI: Потребляемая мощность (компрессор + двигатель вентилятора наружного блока) (кВт)

Продолжение таблицы на следующей странице...

Таблица 2-8.27: Частичная тепловая нагрузка для блоков производительностью 22 л.с. (продолжение)

Частичная нагрузка	Температура наружного воздуха (°CDB)		Температура в помещении (°C DB/WD)											
			16.0		18.0		20.0		21.0		22.0		24.0	
			ТС	PI	ТС	PI	ТС	PI	ТС	PI	ТС	PI	ТС	PI
°C DB	°C WB	кВт	кВт	кВт	кВт	кВт	кВт	кВт	кВт	кВт	кВт	кВт	кВт	
50%	-25	-25.4	35.53	13.91	33.19	12.89	30.85	11.89	29.48	12.44	28.31	10.92	25.97	9.98
	-19.8	-20	35.53	13.66	33.19	12.67	30.85	11.68	29.48	11.22	28.31	10.74	25.97	9.82
	-18.8	-19	35.53	13.54	33.19	12.55	30.85	11.58	29.48	13.52	28.31	10.64	25.97	9.72
	-16.7	-17	35.53	13.27	33.19	12.31	30.85	11.36	29.48	10.90	28.31	10.45	25.97	9.55
	-13.7	-15	35.53	13.03	33.19	12.09	30.85	11.17	29.48	10.71	28.31	10.28	25.97	9.38
	-11.8	-13	35.53	12.79	33.19	11.87	30.85	10.98	29.48	10.52	28.31	10.08	25.97	9.24
	-9.8	-11	35.53	12.57	33.19	11.68	30.85	10.78	29.48	10.35	28.31	9.91	25.97	9.07
	-9.5	-10	35.53	12.45	33.19	11.56	30.85	10.69	29.48	10.25	28.31	9.84	25.97	8.99
	-8.5	-9.1	35.53	12.36	33.19	11.48	30.85	10.61	29.48	10.18	28.31	9.77	25.97	8.95
	-7	-7.6	35.53	12.21	33.19	11.34	30.85	10.47	29.48	10.06	28.31	9.65	25.97	8.83
	-5	-5.6	35.53	11.92	33.19	11.07	30.85	10.25	29.48	9.86	28.31	9.45	25.97	8.68
	-3	-3.7	35.53	12.36	33.19	11.48	30.85	10.64	29.48	10.23	28.31	9.82	25.97	8.99
	0	-0.7	35.53	13.01	33.19	12.09	30.85	11.22	29.48	10.78	28.31	10.35	25.97	9.50
	3	2.2	35.53	11.44	33.19	10.66	30.85	9.89	29.48	9.53	28.31	9.14	25.97	8.41
	5	4.1	35.53	10.81	33.19	10.11	30.85	9.45	29.48	9.12	28.31	8.78	25.97	8.12
	7	6	35.53	9.82	33.19	9.26	30.85	8.68	29.48	8.41	28.31	8.12	25.97	7.57
	9	7.9	35.53	9.65	33.19	9.14	30.85	8.63	29.48	8.39	28.31	8.12	25.97	7.64
11	9.8	35.53	9.50	33.19	9.04	30.85	8.58	29.48	8.37	28.31	8.15	25.97	7.69	
13	11.8	35.53	9.38	33.19	8.97	30.85	8.58	29.48	8.37	28.31	8.15	25.97	7.79	
15	13.7	35.53	9.36	33.19	8.97	30.85	8.61	29.48	8.44	28.31	8.27	25.97	7.91	
25%	-25	-25.4	17.73	7.52	16.60	6.93	15.38	6.37	14.81	6.09	14.15	5.82	13.02	5.29
	-19.8	-20	17.73	7.36	16.60	6.79	15.38	6.24	14.81	5.97	14.15	5.70	13.02	5.19
	-18.8	-19	17.73	7.29	16.60	6.73	15.38	6.18	14.81	5.92	14.15	5.65	13.02	5.14
	-16.7	-17	17.73	7.14	16.60	6.59	15.38	6.06	14.81	5.80	14.15	5.55	13.02	5.05
	-13.7	-15	17.73	7.00	16.60	6.46	15.38	5.95	14.81	5.69	14.15	5.45	13.02	4.95
	-11.8	-13	17.73	6.87	16.60	6.35	15.38	5.84	14.81	5.59	14.15	5.34	13.02	4.87
	-9.8	-11	17.73	6.74	16.60	6.23	15.38	5.74	14.81	5.49	14.15	5.25	13.02	4.79
	-9.5	-10	17.73	6.68	16.60	6.17	15.38	5.68	14.81	5.44	14.15	5.21	13.02	4.74
	-8.5	-9.1	17.73	6.63	16.60	6.13	15.38	5.64	14.81	5.40	14.15	5.17	13.02	4.71
	-7	-7.6	17.73	6.53	16.60	6.04	15.38	5.57	14.81	5.33	14.15	5.10	13.02	4.65
	-5	-5.6	17.73	6.35	16.60	5.88	15.38	5.43	14.81	5.21	14.15	4.99	13.02	4.55
	-3	-3.7	17.73	6.58	16.60	6.09	15.38	5.62	14.81	5.40	14.15	5.17	13.02	4.72
	0	-0.7	17.73	6.92	16.60	6.41	15.38	5.93	14.81	5.68	14.15	5.44	13.02	4.98
	3	2.2	17.73	6.05	16.60	5.62	15.38	5.20	14.81	5.00	14.15	4.79	13.02	4.38
	5	4.1	17.73	5.65	16.60	5.27	15.38	4.90	14.81	4.72	14.15	4.54	13.02	4.18
	7	6	17.73	5.07	16.60	4.75	15.38	4.45	14.81	4.29	14.15	4.14	13.02	3.84
	9	7.9	17.73	4.91	16.60	4.63	15.38	4.35	14.81	4.21	14.15	4.09	13.02	3.81
11	9.8	17.73	4.76	16.60	4.52	15.38	4.28	14.81	4.15	14.15	4.04	13.02	3.79	
13	11.8	17.73	4.65	16.60	4.43	15.38	4.21	14.81	4.10	14.15	3.99	13.02	3.78	
15	13.7	17.73	4.57	16.60	4.37	15.38	4.18	14.81	4.09	14.15	3.99	13.02	3.79	

Обозначения:

ТС: Полная производительность (кВт)

PI: Потребляемая мощность (компрессор + двигатель вентилятора наружного блока) (кВт)

MVS FDC II-S

Таблица 2-8.28: Частичная тепловая нагрузка для блоков производительностью 24 л.с.

Частичная нагрузка	Температура наружного воздуха (°C DB)		Температура в помещении (°C DB/WD)											
			16.0		18.0		20.0		21.0		22.0		24.0	
			ТС	PI	ТС	PI	ТС	PI	ТС	PI	ТС	PI	ТС	PI
°C DB	°C WB	кВт	кВт	кВт	кВт	кВт	кВт	кВт	кВт	кВт	кВт	кВт	кВт	
100%	-25	-25.4	54.45	19.91	54.24	20.10	54.03	20.32	54.03	20.44	54.03	20.56	53.81	20.83
	-19.8	-20	54.88	19.91	54.66	20.12	54.45	20.34	54.45	20.46	54.45	20.59	54.24	20.83
	-18.8	-19	55.73	19.95	55.51	20.17	55.30	20.39	55.30	20.49	55.30	20.61	55.09	20.85
	-16.7	-17	56.58	19.98	56.37	20.20	56.37	20.42	56.15	20.54	56.15	20.66	55.94	20.42
	-13.7	-15	57.43	20.03	57.22	20.22	57.22	20.46	57.00	20.56	57.00	20.68	56.79	20.00
	-11.8	-13	58.28	20.05	58.07	20.27	58.07	20.49	57.85	20.61	57.85	20.71	56.79	19.61
	-9.8	-11	58.70	20.08	58.70	20.29	58.49	20.51	58.49	20.61	58.28	20.73	56.79	19.42
	-9.5	-10	59.13	20.10	58.92	20.29	58.92	20.51	58.70	20.63	58.70	20.76	56.79	19.25
	-8.5	-9.1	59.77	20.12	59.77	20.32	59.56	20.54	59.34	20.66	59.34	20.78	56.79	18.98
	-7	-7.6	64.45	20.15	64.23	20.33	64.23	20.55	64.02	21.41	61.90	20.37	56.79	18.38
	-5	-5.6	65.30	20.17	65.09	20.34	65.09	20.56	64.45	22.14	61.90	21.07	56.79	19.01
	-3	-3.7	66.57	20.20	66.36	20.35	66.36	19.88	64.45	20.83	61.90	22.14	56.79	19.98
	0	-0.7	68.28	20.22	72.10	20.36	67.00	19.33	64.45	21.90	61.90	20.88	56.79	18.76
	3	2.2	72.74	21.49	72.10	19.86	67.00	18.77	64.45	20.15	61.90	19.23	56.79	17.38
	5	4.1	77.21	20.38	72.10	18.89	67.00	17.89	64.45	18.40	61.90	17.58	56.79	16.00
	7	6	77.21	19.26	72.10	17.92	67.00	16.75	64.45	16.09	61.90	15.41	56.79	14.13
9	7.9	77.21	18.16	72.10	16.97	67.00	15.78	64.45	15.20	61.90	14.61	56.79	13.47	
11	9.8	77.21	16.99	72.10	15.92	67.00	14.91	64.45	14.40	61.90	13.89	56.79	12.89	
13	11.8	77.21	15.92	72.10	15.03	67.00	14.13	64.45	13.69	61.90	13.25	56.79	12.38	
15	13.7	77.21	15.15	72.10	14.37	67.00	13.57	64.45	13.18	61.90	12.79	56.79	12.02	
75%	-25	-25.4	57.40	21.72	53.90	19.98	50.26	18.30	48.21	17.48	46.39	16.67	42.53	15.09
	-19.8	-20	57.31	21.27	53.90	19.57	50.26	17.94	48.21	17.13	46.39	16.34	42.53	14.79
	-18.8	-19	57.77	21.04	53.90	19.37	50.26	17.74	48.21	16.95	46.39	16.19	42.53	14.66
	-16.7	-17	57.77	20.61	53.90	18.99	50.26	17.41	48.21	16.62	46.39	15.86	42.53	14.38
	-13.7	-15	57.77	20.20	53.90	18.60	50.26	17.05	48.21	16.32	46.39	15.55	42.53	14.11
	-11.8	-13	57.77	19.80	53.90	18.25	50.26	16.75	48.21	15.99	46.39	15.27	42.53	13.85
	-9.8	-11	57.77	19.42	53.90	17.89	50.26	16.42	48.21	15.71	46.39	14.99	42.53	13.60
	-9.5	-10	57.77	19.24	53.90	17.74	50.26	16.27	48.21	15.55	46.39	14.84	42.53	13.50
	-8.5	-9.1	57.77	19.06	53.90	17.59	50.26	16.14	48.21	15.43	46.39	14.74	42.53	13.37
	-7	-7.6	57.77	18.81	53.90	17.33	50.26	15.91	48.21	15.22	46.39	14.54	42.53	13.19
	-5	-5.6	57.77	18.22	53.90	16.82	50.26	15.48	48.21	14.82	46.39	14.16	42.53	12.89
	-3	-3.7	57.77	18.86	53.90	17.41	50.26	16.01	48.21	15.33	46.39	14.66	42.53	13.34
	0	-0.7	57.77	19.82	53.90	18.32	50.26	16.85	48.21	16.14	46.39	15.43	42.53	14.05
	3	2.2	57.77	17.26	53.90	15.99	50.26	14.74	48.21	14.13	46.39	13.52	42.53	12.35
	5	4.1	57.77	15.94	53.90	14.84	50.26	13.75	48.21	13.22	46.39	12.68	42.53	11.64
	7	6	57.77	14.13	53.90	13.22	50.26	12.33	48.21	11.87	46.39	11.44	42.53	10.57
9	7.9	57.77	13.52	53.90	12.71	50.26	11.92	48.21	14.08	46.39	11.13	42.53	10.37	
11	9.8	57.77	12.99	53.90	12.28	50.26	11.56	48.21	11.23	46.39	10.88	42.53	10.19	
13	11.8	57.77	12.50	53.90	11.89	50.26	11.26	48.21	10.95	46.39	10.65	42.53	10.04	
15	13.7	57.77	12.17	53.90	11.61	50.26	11.08	48.21	10.80	46.39	10.52	42.53	9.99	

Обозначения:

ТС: Полная производительность (кВт)

PI: Потребляемая мощность (компрессор + двигатель вентилятора наружного блока) (кВт)

Продолжение таблицы на следующей странице...

Таблица 2-8.28: Частичная тепловая нагрузка для блоков производительностью 24 л.с. (продолжение)

Частичная нагрузка	Температура наружного воздуха (°CDB)		Температура в помещении (°C DB/WD)											
			16.0		18.0		20.0		21.0		22.0		24.0	
	°C DB	°C WB	ТС	PI	ТС	PI	ТС	PI	ТС	PI	ТС	PI	ТС	PI
50%	-25	-25.4	38.71	13.26	36.16	12.29	33.61	11.33	32.12	11.86	30.84	10.41	28.29	9.51
	-19.8	-20	38.71	13.02	36.16	12.08	33.61	11.13	32.12	10.70	30.84	10.23	28.29	9.36
	-18.8	-19	38.71	12.91	36.16	11.96	33.61	11.04	32.12	12.89	30.84	10.14	28.29	9.27
	-16.7	-17	38.71	12.65	36.16	11.73	33.61	10.83	32.12	10.40	30.84	9.96	28.29	9.10
	-13.7	-15	38.71	12.42	36.16	11.53	33.61	10.65	32.12	10.21	30.84	9.80	28.29	8.94
	-11.8	-13	38.71	12.19	36.16	11.32	33.61	10.46	32.12	10.03	30.84	9.61	28.29	8.81
	-9.8	-11	38.71	11.99	36.16	11.13	33.61	10.28	32.12	9.87	30.84	9.45	28.29	8.64
	-9.5	-10	38.71	11.87	36.16	11.02	33.61	10.19	32.12	9.77	30.84	9.38	28.29	8.57
	-8.5	-9.1	38.71	11.78	36.16	10.95	33.61	10.12	32.12	9.70	30.84	9.31	28.29	8.53
	-7	-7.6	38.71	11.64	36.16	10.81	33.61	9.98	32.12	9.59	30.84	9.20	28.29	8.41
	-5	-5.6	38.71	11.36	36.16	10.56	33.61	9.77	32.12	9.40	30.84	9.01	28.29	8.27
	-3	-3.7	38.71	11.78	36.16	10.95	33.61	10.14	32.12	9.75	30.84	9.36	28.29	8.57
	0	-0.7	38.71	12.40	36.16	11.53	33.61	10.70	32.12	10.28	30.84	9.87	28.29	9.06
	3	2.2	38.71	10.90	36.16	10.17	33.61	9.43	32.12	9.08	30.84	8.71	28.29	8.02
	5	4.1	38.71	10.30	36.16	9.63	33.61	9.01	32.12	8.69	30.84	8.37	28.29	7.74
	7	6	38.71	9.36	36.16	8.83	33.61	8.27	32.12	8.02	30.84	7.74	28.29	7.21
	9	7.9	38.71	9.20	36.16	8.71	33.61	8.23	32.12	8.00	30.84	7.74	28.29	7.28
11	9.8	38.71	9.06	36.16	8.62	33.61	8.18	32.12	7.98	30.84	7.77	28.29	7.33	
13	11.8	38.71	8.94	36.16	8.55	33.61	8.18	32.12	7.98	30.84	7.77	28.29	7.42	
15	13.7	38.71	8.92	36.16	8.55	33.61	8.21	32.12	8.04	30.84	7.88	28.29	7.54	
25%	-25	-25.4	19.32	7.17	18.08	6.61	16.75	6.07	16.13	5.80	15.42	5.55	14.18	5.04
	-19.8	-20	19.32	7.02	18.08	6.47	16.75	5.95	16.13	5.69	15.42	5.44	14.18	4.94
	-18.8	-19	19.32	6.95	18.08	6.41	16.75	5.89	16.13	5.64	15.42	5.39	14.18	4.90
	-16.7	-17	19.32	6.81	18.08	6.28	16.75	5.78	16.13	5.53	15.42	5.29	14.18	4.81
	-13.7	-15	19.32	6.68	18.08	6.16	16.75	5.67	16.13	5.43	15.42	5.20	14.18	4.72
	-11.8	-13	19.32	6.55	18.08	6.05	16.75	5.57	16.13	5.33	15.42	5.10	14.18	4.64
	-9.8	-11	19.32	6.42	18.08	5.94	16.75	5.47	16.13	5.24	15.42	5.00	14.18	4.56
	-9.5	-10	19.32	6.36	18.08	5.88	16.75	5.42	16.13	5.19	15.42	4.96	14.18	4.52
	-8.5	-9.1	19.32	6.32	18.08	5.84	16.75	5.38	16.13	5.15	15.42	4.92	14.18	4.49
	-7	-7.6	19.32	6.22	18.08	5.76	16.75	5.31	16.13	5.09	15.42	4.86	14.18	4.43
	-5	-5.6	19.32	6.05	18.08	5.61	16.75	5.18	16.13	4.96	15.42	4.75	14.18	4.34
	-3	-3.7	19.32	6.27	18.08	5.81	16.75	5.36	16.13	5.15	15.42	4.92	14.18	4.50
	0	-0.7	19.32	6.60	18.08	6.11	16.75	5.65	16.13	5.42	15.42	5.19	14.18	4.74
	3	2.2	19.32	5.77	18.08	5.36	16.75	4.95	16.13	4.76	15.42	4.56	14.18	4.18
	5	4.1	19.32	5.39	18.08	5.02	16.75	4.67	16.13	4.50	15.42	4.33	14.18	3.99
	7	6	19.32	4.83	18.08	4.53	16.75	4.24	16.13	4.09	15.42	3.95	14.18	3.67
	9	7.9	19.32	4.68	18.08	4.41	16.75	4.15	16.13	4.02	15.42	3.90	14.18	3.64
11	9.8	19.32	4.54	18.08	4.31	16.75	4.08	16.13	3.96	15.42	3.85	14.18	3.62	
13	11.8	19.32	4.43	18.08	4.22	16.75	4.02	16.13	3.91	15.42	3.81	14.18	3.61	
15	13.7	19.32	4.36	18.08	4.17	16.75	3.99	16.13	3.90	15.42	3.81	14.18	3.62	

Обозначения:

ТС: Полная производительность (кВт)

PI: Потребляемая мощность (компрессор + двигатель вентилятора наружного блока) (кВт)

MVS FDC II-S

Таблица 2-8.29: Частичная тепловая нагрузка для блоков производительностью 26 л.с.

Частичная нагрузка	Температура наружного воздуха (°CDB)		Температура в помещении (°C DB/WD)											
			16.0		18.0		20.0		21.0		22.0		24.0	
	°C DB	°C WB	ТС	PI	ТС	PI	ТС	PI	ТС	PI	ТС	PI	ТС	PI
100%	-25	-25.4	59.33	21.42	59.10	21.62	58.86	21.86	58.86	21.99	58.86	22.12	58.63	22.41
	-19.8	-20	59.79	21.42	59.56	21.65	59.33	21.89	59.33	22.02	59.33	22.15	59.10	22.41
	-18.8	-19	60.72	21.47	60.49	21.70	60.25	21.94	60.25	22.04	60.25	22.17	60.02	22.43
	-16.7	-17	61.64	21.49	61.41	21.73	61.41	21.96	61.18	22.09	61.18	22.22	60.95	21.96
	-13.7	-15	62.57	21.55	62.34	21.75	62.34	22.02	62.11	22.12	62.11	22.25	61.88	21.52
	-11.8	-13	63.50	21.57	63.27	21.81	63.27	22.04	63.03	22.17	63.03	22.28	61.88	21.10
	-9.8	-11	63.96	21.60	63.96	21.83	63.73	22.07	63.73	22.17	63.50	22.30	61.88	20.89
	-9.5	-10	64.43	21.62	64.19	21.83	64.19	22.07	63.96	22.20	63.96	22.33	61.88	20.71
	-8.5	-9.1	65.12	21.65	65.12	21.86	64.89	22.09	64.66	22.22	64.66	22.36	61.88	20.42
	-7	-7.6	70.22	21.68	69.99	21.87	69.99	22.10	69.76	23.03	67.44	21.91	61.88	19.77
	-5	-5.6	71.15	21.70	70.91	21.88	70.91	22.12	70.22	23.82	67.44	22.67	61.88	20.45
	-3	-3.7	72.54	21.73	72.30	21.89	72.30	21.39	70.22	22.41	67.44	23.82	61.88	21.49
	0	-0.7	74.39	21.75	78.56	21.91	73.00	20.79	70.22	23.56	67.44	22.46	61.88	20.19
	3	2.2	79.26	23.12	78.56	21.36	73.00	20.20	70.22	21.68	67.44	20.68	61.88	18.70
	5	4.1	84.12	21.92	78.56	20.32	73.00	19.24	70.22	19.80	67.44	18.91	61.88	17.21
	7	6	84.12	20.72	78.56	19.27	73.00	18.02	70.22	17.31	67.44	16.58	61.88	15.20
	9	7.9	84.12	19.53	78.56	18.26	73.00	16.98	70.22	16.35	67.44	15.72	61.88	14.49
11	9.8	84.12	18.28	78.56	17.13	73.00	16.04	70.22	15.49	67.44	14.94	61.88	13.87	
13	11.8	84.12	17.13	78.56	16.17	73.00	15.20	70.22	14.73	67.44	14.26	61.88	13.32	
15	13.7	84.12	16.30	78.56	15.46	73.00	14.60	70.22	14.18	67.44	13.76	61.88	12.93	
75%	-25	-25.4	62.54	23.37	58.73	21.49	54.76	19.69	52.53	18.80	50.55	17.94	46.34	16.24
	-19.8	-20	62.44	22.89	58.73	21.05	54.76	19.30	52.53	18.43	50.55	17.58	46.34	15.91
	-18.8	-19	62.94	22.64	58.73	20.83	54.76	19.08	52.53	18.24	50.55	17.42	46.34	15.78
	-16.7	-17	62.94	22.17	58.73	20.42	54.76	18.73	52.53	17.88	50.55	17.06	46.34	15.48
	-13.7	-15	62.94	21.74	58.73	20.01	54.76	18.35	52.53	17.55	50.55	16.73	46.34	15.17
	-11.8	-13	62.94	21.30	58.73	19.63	54.76	18.02	52.53	17.20	50.55	16.43	46.34	14.90
	-9.8	-11	62.94	20.89	58.73	19.25	54.76	17.66	52.53	16.90	50.55	16.13	46.34	14.63
	-9.5	-10	62.94	20.70	58.73	19.08	54.76	17.50	52.53	16.73	50.55	15.97	46.34	14.52
	-8.5	-9.1	62.94	20.51	58.73	18.92	54.76	17.36	52.53	16.60	50.55	15.86	46.34	14.38
	-7	-7.6	62.94	20.23	58.73	18.65	54.76	17.12	52.53	16.38	50.55	15.64	46.34	14.19
	-5	-5.6	62.94	19.60	58.73	18.10	54.76	16.65	52.53	15.94	50.55	15.23	46.34	13.86
	-3	-3.7	62.94	20.29	58.73	18.73	54.76	17.23	52.53	16.49	50.55	15.78	46.34	14.35
	0	-0.7	62.94	21.33	58.73	19.71	54.76	18.13	52.53	17.36	50.55	16.60	46.34	15.12
	3	2.2	62.94	18.57	58.73	17.20	54.76	15.86	52.53	15.20	50.55	14.55	46.34	13.29
	5	4.1	62.94	17.14	58.73	15.97	54.76	14.79	52.53	14.22	50.55	13.64	46.34	12.52
	7	6	62.94	15.20	58.73	14.22	54.76	13.26	52.53	12.77	50.55	12.30	46.34	11.37
	9	7.9	62.94	14.55	58.73	13.67	54.76	12.82	52.53	15.15	50.55	11.98	46.34	11.16
11	9.8	62.94	13.97	58.73	13.21	54.76	12.44	52.53	12.09	50.55	11.70	46.34	10.96	
13	11.8	62.94	13.45	58.73	12.80	54.76	12.11	52.53	11.78	50.55	11.46	46.34	10.80	
15	13.7	62.94	13.10	58.73	12.50	54.76	11.92	52.53	11.62	50.55	11.32	46.34	10.75	

Обозначения:

ТС: Полная производительность (кВт)

PI: Потребляемая мощность (компрессор + двигатель вентилятора наружного блока) (кВт)

Продолжение таблицы на следующей странице...

Таблица 2-8.29: Частичная тепловая нагрузка для блоков производительностью 26 л.с. (продолжение)

Частичная нагрузка	Температура наружного воздуха (°CDB)		Температура в помещении (°C DB/WD)											
			16.0		18.0		20.0		21.0		22.0		24.0	
			ТС	PI	ТС	PI	ТС	PI	ТС	PI	ТС	PI	ТС	PI
°C DB	°C WB	кВт	кВт	кВт	кВт	кВт	кВт	кВт	кВт	кВт	кВт	кВт	кВт	
50%	-25	-25.4	42.18	14.27	39.40	13.22	36.62	12.19	34.99	12.76	33.60	11.20	30.82	10.23
	-19.8	-20	42.18	14.01	39.40	12.99	36.62	11.98	34.99	11.51	33.60	11.01	30.82	10.07
	-18.8	-19	42.18	13.89	39.40	12.87	36.62	11.88	34.99	13.86	33.60	10.91	30.82	9.97
	-16.7	-17	42.18	13.61	39.40	12.62	36.62	11.65	34.99	11.18	33.60	10.71	30.82	9.80
	-13.7	-15	42.18	13.37	39.40	12.40	36.62	11.46	34.99	10.99	33.60	10.54	30.82	9.62
	-11.8	-13	42.18	13.12	39.40	12.18	36.62	11.26	34.99	10.79	33.60	10.34	30.82	9.47
	-9.8	-11	42.18	12.89	39.40	11.98	36.62	11.06	34.99	10.61	33.60	10.17	30.82	9.30
	-9.5	-10	42.18	12.77	39.40	11.85	36.62	10.96	34.99	10.51	33.60	10.09	30.82	9.22
	-8.5	-9.1	42.18	12.67	39.40	11.78	36.62	10.89	34.99	10.44	33.60	10.02	30.82	9.18
	-7	-7.6	42.18	12.52	39.40	11.63	36.62	10.74	34.99	10.32	33.60	9.89	30.82	9.05
	-5	-5.6	42.18	12.23	39.40	11.36	36.62	10.51	34.99	10.12	33.60	9.70	30.82	8.90
	-3	-3.7	42.18	12.67	39.40	11.78	36.62	10.91	34.99	10.49	33.60	10.07	30.82	9.22
	0	-0.7	42.18	13.34	39.40	12.40	36.62	11.51	34.99	11.06	33.60	10.61	30.82	9.75
	3	2.2	42.18	11.73	39.40	10.94	36.62	10.14	34.99	9.77	33.60	9.37	30.82	8.63
	5	4.1	42.18	11.08	39.40	10.37	36.62	9.70	34.99	9.35	33.60	9.00	30.82	8.33
	7	6	42.18	10.07	39.40	9.50	36.62	8.90	34.99	8.63	33.60	8.33	30.82	7.76
	9	7.9	42.18	9.89	39.40	9.37	36.62	8.85	34.99	8.60	33.60	8.33	30.82	7.84
11	9.8	42.18	9.75	39.40	9.27	36.62	8.80	34.99	8.58	33.60	8.36	30.82	7.89	
13	11.8	42.18	9.62	39.40	9.20	36.62	8.80	34.99	8.58	33.60	8.36	30.82	7.98	
15	13.7	42.18	9.60	39.40	9.20	36.62	8.83	34.99	8.65	33.60	8.48	30.82	8.11	
25%	-25	-25.4	21.05	7.71	19.70	7.11	18.25	6.53	17.57	6.25	16.80	5.97	15.45	5.43
	-19.8	-20	21.05	7.55	19.70	6.97	18.25	6.40	17.57	6.12	16.80	5.85	15.45	5.32
	-18.8	-19	21.05	7.48	19.70	6.90	18.25	6.34	17.57	6.07	16.80	5.80	15.45	5.28
	-16.7	-17	21.05	7.32	19.70	6.76	18.25	6.22	17.57	5.95	16.80	5.69	15.45	5.18
	-13.7	-15	21.05	7.18	19.70	6.63	18.25	6.10	17.57	5.84	16.80	5.59	15.45	5.08
	-11.8	-13	21.05	7.04	19.70	6.51	18.25	5.99	17.57	5.73	16.80	5.48	15.45	4.99
	-9.8	-11	21.05	6.91	19.70	6.39	18.25	5.88	17.57	5.63	16.80	5.38	15.45	4.91
	-9.5	-10	21.05	6.85	19.70	6.33	18.25	5.83	17.57	5.58	16.80	5.34	15.45	4.86
	-8.5	-9.1	21.05	6.80	19.70	6.28	18.25	5.79	17.57	5.54	16.80	5.30	15.45	4.83
	-7	-7.6	21.05	6.70	19.70	6.20	18.25	5.71	17.57	5.47	16.80	5.23	15.45	4.77
	-5	-5.6	21.05	6.51	19.70	6.03	18.25	5.57	17.57	5.34	16.80	5.11	15.45	4.67
	-3	-3.7	21.05	6.75	19.70	6.25	18.25	5.76	17.57	5.54	16.80	5.30	15.45	4.84
	0	-0.7	21.05	7.10	19.70	6.58	18.25	6.08	17.57	5.83	16.80	5.58	15.45	5.10
	3	2.2	21.05	6.21	19.70	5.76	18.25	5.33	17.57	5.12	16.80	4.91	15.45	4.50
	5	4.1	21.05	5.80	19.70	5.41	18.25	5.03	17.57	4.84	16.80	4.66	15.45	4.29
	7	6	21.05	5.20	19.70	4.88	18.25	4.56	17.57	4.40	16.80	4.25	15.45	3.94
	9	7.9	21.05	5.04	19.70	4.75	18.25	4.46	17.57	4.32	16.80	4.19	15.45	3.91
11	9.8	21.05	4.89	19.70	4.64	18.25	4.39	17.57	4.26	16.80	4.14	15.45	3.89	
13	11.8	21.05	4.77	19.70	4.54	18.25	4.32	17.57	4.20	16.80	4.10	15.45	3.88	
15	13.7	21.05	4.69	19.70	4.49	18.25	4.29	17.57	4.19	16.80	4.10	15.45	3.89	

Обозначения:

ТС: Полная производительность (кВт)

PI: Потребляемая мощность (компрессор + двигатель вентилятора наружного блока) (кВт)

MVS FDC II-S

Таблица 2-8.30: Частичная тепловая нагрузка для блоков производительностью 28 л.с.

Частичная нагрузка	Температура наружного воздуха (°CDB)		Температура в помещении (°C DB/WD)											
			16.0		18.0		20.0		21.0		22.0		24.0	
			ТС	PI	ТС	PI	ТС	PI	ТС	PI	ТС	PI	ТС	PI
°C DB	°C WB	кВт	кВт	кВт	кВт	кВт	кВт	кВт	кВт	кВт	кВт	кВт	кВт	
100%	-25	-25.4	63.80	25.92	63.55	26.17	63.30	26.46	63.30	26.61	63.30	26.77	63.05	27.12
	-19.8	-20	64.30	25.92	64.05	26.20	63.80	26.49	63.80	26.65	63.80	26.80	63.55	27.12
	-18.8	-19	65.29	25.98	65.04	26.27	64.79	26.55	64.79	26.68	64.79	26.84	64.54	27.15
	-16.7	-17	66.29	26.01	66.04	26.30	66.04	26.58	65.79	26.74	65.79	26.90	65.54	26.58
	-13.7	-15	67.29	26.08	67.04	26.33	67.04	26.65	66.79	26.77	66.79	26.93	66.54	26.05
	-11.8	-13	68.28	26.11	68.03	26.39	68.03	26.68	67.78	26.84	67.78	26.96	66.54	25.54
	-9.8	-11	68.78	26.14	68.78	26.42	68.53	26.71	68.53	26.84	68.28	26.99	66.54	25.29
	-9.5	-10	69.28	26.17	69.03	26.42	69.03	26.71	68.78	26.87	68.78	27.03	66.54	25.07
	-8.5	-9.1	70.03	26.20	70.03	26.46	69.78	26.74	69.53	26.90	69.53	27.06	66.54	24.72
	-7	-7.6	75.51	26.24	75.26	26.47	75.26	26.75	75.01	27.88	72.52	26.52	66.54	23.93
	-5	-5.6	76.51	26.27	76.26	26.48	76.26	26.77	75.51	28.83	72.52	27.44	66.54	24.75
	-3	-3.7	78.00	26.30	77.75	26.50	77.75	25.89	75.51	27.12	72.52	28.83	66.54	26.01
	0	-0.7	80.00	26.33	84.48	26.51	78.50	25.17	75.51	28.51	72.52	27.18	66.54	24.43
	3	2.2	85.23	27.98	84.48	25.86	78.50	24.45	75.51	26.24	72.52	25.03	66.54	22.63
	5	4.1	90.46	26.53	84.48	24.59	78.50	23.29	75.51	23.96	72.52	22.88	66.54	20.83
	7	6	90.46	25.08	84.48	23.33	78.50	21.81	75.51	20.96	72.52	20.07	66.54	18.40
9	7.9	90.46	23.64	84.48	22.09	78.50	20.55	75.51	19.79	72.52	19.03	66.54	17.54	
11	9.8	90.46	22.13	84.48	20.74	78.50	19.41	75.51	18.74	72.52	18.08	66.54	16.78	
13	11.8	90.46	20.74	84.48	19.57	78.50	18.40	75.51	17.83	72.52	17.26	66.54	16.12	
15	13.7	90.46	19.72	84.48	18.71	78.50	17.67	75.51	17.16	72.52	16.66	66.54	15.65	
75%	-25	-25.4	67.25	28.28	63.15	26.01	58.89	23.83	56.49	22.76	54.36	21.71	49.83	19.65
	-19.8	-20	67.15	27.70	63.15	25.48	58.89	23.36	56.49	22.30	54.36	21.28	49.83	19.26
	-18.8	-19	67.68	27.40	63.15	25.22	58.89	23.10	56.49	22.07	54.36	21.08	49.83	19.09
	-16.7	-17	67.68	26.84	63.15	24.72	58.89	22.67	56.49	21.64	54.36	20.65	49.83	18.73
	-13.7	-15	67.68	26.31	63.15	24.22	58.89	22.21	56.49	21.25	54.36	20.25	49.83	18.37
	-11.8	-13	67.68	25.78	63.15	23.76	58.89	21.81	56.49	20.82	54.36	19.89	49.83	18.04
	-9.8	-11	67.68	25.28	63.15	23.30	58.89	21.38	56.49	20.45	54.36	19.52	49.83	17.70
	-9.5	-10	67.68	25.05	63.15	23.10	58.89	21.18	56.49	20.25	54.36	19.33	49.83	17.57
	-8.5	-9.1	67.68	24.82	63.15	22.90	58.89	21.01	56.49	20.09	54.36	19.19	49.83	17.41
	-7	-7.6	67.68	24.49	63.15	22.57	58.89	20.72	56.49	19.82	54.36	18.93	49.83	17.18
	-5	-5.6	67.68	23.73	63.15	21.91	58.89	20.15	56.49	19.29	54.36	18.43	49.83	16.78
	-3	-3.7	67.68	24.55	63.15	22.67	58.89	20.85	56.49	19.95	54.36	19.09	49.83	17.37
	0	-0.7	67.68	25.81	63.15	23.86	58.89	21.94	56.49	21.01	54.36	20.09	49.83	18.30
	3	2.2	67.68	22.47	63.15	20.82	58.89	19.19	56.49	18.40	54.36	17.61	49.83	16.08
	5	4.1	67.68	20.75	63.15	19.33	58.89	17.90	56.49	17.21	54.36	16.51	49.83	15.16
	7	6	67.68	18.40	63.15	17.21	58.89	16.05	56.49	15.45	54.36	14.89	49.83	13.77
9	7.9	67.68	17.61	63.15	16.55	58.89	15.52	56.49	18.33	54.36	14.49	49.83	13.50	
11	9.8	67.68	16.91	63.15	15.98	58.89	15.06	56.49	14.63	54.36	14.16	49.83	13.27	
13	11.8	67.68	16.28	63.15	15.49	58.89	14.66	56.49	14.26	54.36	13.87	49.83	13.07	
15	13.7	67.68	15.85	63.15	15.12	58.89	14.43	56.49	14.06	54.36	13.70	49.83	13.01	

Обозначения:

ТС: Полная производительность (кВт)

PI: Потребляемая мощность (компрессор + двигатель вентилятора наружного блока) (кВт)

Продолжение таблицы на следующей странице...

Таблица 2-8.30: Частичная тепловая нагрузка для блоков производительностью 28 л.с. (продолжение)

Частичная нагрузка	Температура наружного воздуха (°CDB)		Температура в помещении (°C DB/WD)											
			16.0		18.0		20.0		21.0		22.0		24.0	
			ТС	PI	ТС	PI	ТС	PI	ТС	PI	ТС	PI	ТС	PI
°C DB	°C WB	кВт	кВт	кВт	кВт	кВт	кВт	кВт	кВт	кВт	кВт	кВт	кВт	
50%	-25	-25.4	45.36	17.27	42.37	16.00	39.37	14.75	37.63	15.44	36.13	13.55	33.14	12.39
	-19.8	-20	45.36	16.96	42.37	15.73	39.37	14.50	37.63	13.93	36.13	13.33	33.14	12.19
	-18.8	-19	45.36	16.81	42.37	15.58	39.37	14.38	37.63	16.78	36.13	13.21	33.14	12.07
	-16.7	-17	45.36	16.48	42.37	15.28	39.37	14.11	37.63	13.54	36.13	12.97	33.14	11.86
	-13.7	-15	45.36	16.18	42.37	15.01	39.37	13.87	37.63	13.30	36.13	12.76	33.14	11.65
	-11.8	-13	45.36	15.88	42.37	14.74	39.37	13.63	37.63	13.06	36.13	12.52	33.14	11.47
	-9.8	-11	45.36	15.61	42.37	14.50	39.37	13.39	37.63	12.85	36.13	12.31	33.14	11.25
	-9.5	-10	45.36	15.46	42.37	14.35	39.37	13.27	37.63	12.73	36.13	12.22	33.14	11.16
	-8.5	-9.1	45.36	15.34	42.37	14.26	39.37	13.18	37.63	12.64	36.13	12.13	33.14	11.10
	-7	-7.6	45.36	15.16	42.37	14.08	39.37	13.00	37.63	12.49	36.13	11.98	33.14	10.95
	-5	-5.6	45.36	14.80	42.37	13.75	39.37	12.73	37.63	12.25	36.13	11.74	33.14	10.77
	-3	-3.7	45.36	15.34	42.37	14.26	39.37	13.21	37.63	12.70	36.13	12.19	33.14	11.16
	0	-0.7	45.36	16.15	42.37	15.01	39.37	13.93	37.63	13.39	36.13	12.85	33.14	11.80
	3	2.2	45.36	14.20	42.37	13.24	39.37	12.28	37.63	11.83	36.13	11.35	33.14	10.44
	5	4.1	45.36	13.42	42.37	12.55	39.37	11.74	37.63	11.32	36.13	10.89	33.14	10.08
	7	6	45.36	12.19	42.37	11.50	39.37	10.77	37.63	10.44	36.13	10.08	33.14	9.39
9	7.9	45.36	11.98	42.37	11.35	39.37	10.71	37.63	10.41	36.13	10.08	33.14	9.48	
11	9.8	45.36	11.80	42.37	11.22	39.37	10.65	37.63	10.38	36.13	10.11	33.14	9.54	
13	11.8	45.36	11.65	42.37	11.13	39.37	10.65	37.63	10.38	36.13	10.11	33.14	9.66	
15	13.7	45.36	11.62	42.37	11.13	39.37	10.68	37.63	10.47	36.13	10.26	33.14	9.81	
25%	-25	-25.4	22.64	9.33	21.18	8.61	19.63	7.90	18.90	7.56	18.07	7.22	16.61	6.57
	-19.8	-20	22.64	9.14	21.18	8.43	19.63	7.75	18.90	7.41	18.07	7.08	16.61	6.44
	-18.8	-19	22.64	9.05	21.18	8.35	19.63	7.67	18.90	7.34	18.07	7.01	16.61	6.39
	-16.7	-17	22.64	8.86	21.18	8.18	19.63	7.53	18.90	7.20	18.07	6.88	16.61	6.27
	-13.7	-15	22.64	8.69	21.18	8.02	19.63	7.38	18.90	7.07	18.07	6.77	16.61	6.15
	-11.8	-13	22.64	8.52	21.18	7.88	19.63	7.25	18.90	6.94	18.07	6.63	16.61	6.04
	-9.8	-11	22.64	8.37	21.18	7.74	19.63	7.12	18.90	6.82	18.07	6.52	16.61	5.94
	-9.5	-10	22.64	8.29	21.18	7.66	19.63	7.05	18.90	6.75	18.07	6.46	16.61	5.89
	-8.5	-9.1	22.64	8.23	21.18	7.60	19.63	7.00	18.90	6.70	18.07	6.41	16.61	5.85
	-7	-7.6	22.64	8.10	21.18	7.50	19.63	6.91	18.90	6.62	18.07	6.33	16.61	5.77
	-5	-5.6	22.64	7.88	21.18	7.30	19.63	6.74	18.90	6.46	18.07	6.19	16.61	5.65
	-3	-3.7	22.64	8.17	21.18	7.57	19.63	6.98	18.90	6.70	18.07	6.41	16.61	5.86
	0	-0.7	22.64	8.59	21.18	7.96	19.63	7.36	18.90	7.05	18.07	6.75	16.61	6.18
	3	2.2	22.64	7.51	21.18	6.98	19.63	6.45	18.90	6.20	18.07	5.94	16.61	5.44
	5	4.1	22.64	7.01	21.18	6.54	19.63	6.08	18.90	5.86	18.07	5.64	16.61	5.19
	7	6	22.64	6.29	21.18	5.90	19.63	5.52	18.90	5.32	18.07	5.14	16.61	4.77
9	7.9	22.64	6.10	21.18	5.74	19.63	5.40	18.90	5.23	18.07	5.07	16.61	4.73	
11	9.8	22.64	5.91	21.18	5.61	19.63	5.31	18.90	5.15	18.07	5.01	16.61	4.71	
13	11.8	22.64	5.77	21.18	5.49	19.63	5.23	18.90	5.09	18.07	4.96	16.61	4.69	
15	13.7	22.64	5.68	21.18	5.43	19.63	5.19	18.90	5.07	18.07	4.96	16.61	4.71	

Обозначения:

ТС: Полная производительность (кВт)

PI: Потребляемая мощность (компрессор + двигатель вентилятора наружного блока) (кВт)

MVS FDC II-S

Таблица 2-8.31: Частичная тепловая нагрузка для блоков производительностью 30 л.с.

Частичная нагрузка	Температура наружного воздуха (°CDB)		Температура в помещении (°C DB/WD)											
			16.0		18.0		20.0		21.0		22.0		24.0	
	°C DB	°C WB	ТС	PI	ТС	PI	ТС	PI	ТС	PI	ТС	PI	ТС	PI
100%	-25	-25.4	69.08	28.85	68.81	29.14	68.54	29.45	68.54	29.63	68.54	29.80	68.27	30.19
	-19.8	-20	69.62	28.85	69.35	29.17	69.08	29.49	69.08	29.66	69.08	29.84	68.81	30.19
	-18.8	-19	70.70	28.92	70.43	29.24	70.16	29.56	70.16	29.70	70.16	29.87	69.89	30.23
	-16.7	-17	71.78	28.96	71.51	29.28	71.51	29.59	71.24	29.77	71.24	29.95	70.97	29.59
	-13.7	-15	72.86	29.03	72.59	29.31	72.59	29.66	72.32	29.80	72.32	29.98	72.05	29.00
	-11.8	-13	73.94	29.07	73.67	29.38	73.67	29.70	73.40	29.87	73.40	30.02	72.05	28.43
	-9.8	-11	74.48	29.10	74.48	29.42	74.21	29.73	74.21	29.87	73.94	30.05	72.05	28.15
	-9.5	-10	75.02	29.14	74.75	29.42	74.75	29.73	74.48	29.91	74.48	30.09	72.05	27.90
	-8.5	-9.1	75.83	29.17	75.83	29.45	75.56	29.77	75.29	29.95	75.29	30.12	72.05	27.52
	-7	-7.6	81.76	29.21	81.49	29.46	81.49	29.78	81.22	31.04	78.52	29.52	72.05	26.64
	-5	-5.6	82.84	29.24	82.57	29.48	82.57	29.80	81.76	32.09	78.52	30.54	72.05	27.55
	-3	-3.7	84.46	29.28	84.19	29.50	84.19	28.82	81.76	30.19	78.52	32.09	72.05	28.96
	0	-0.7	86.62	29.31	91.48	29.52	85.00	28.02	81.76	31.74	78.52	30.26	72.05	27.20
	3	2.2	92.29	31.15	91.48	28.78	85.00	27.21	81.76	29.21	78.52	27.87	72.05	25.19
	5	4.1	97.95	29.53	91.48	27.38	85.00	25.93	81.76	26.67	78.52	25.48	72.05	23.19
	7	6	97.95	27.92	91.48	25.97	85.00	24.28	81.76	23.33	78.52	22.34	72.05	20.48
	9	7.9	97.95	26.32	91.48	24.60	85.00	22.87	81.76	22.03	78.52	21.18	72.05	19.53
11	9.8	97.95	24.63	91.48	23.08	85.00	21.61	81.76	20.87	78.52	20.13	72.05	18.69	
13	11.8	97.95	23.08	91.48	21.78	85.00	20.48	81.76	19.85	78.52	19.21	72.05	17.95	
15	13.7	97.95	21.96	91.48	20.83	85.00	19.67	81.76	19.11	78.52	18.54	72.05	17.42	
75%	-25	-25.4	72.82	31.49	68.38	28.96	63.76	26.53	61.17	25.34	58.86	24.17	53.95	21.88
	-19.8	-20	72.71	30.84	68.38	28.37	63.76	26.01	61.17	24.83	58.86	23.69	53.95	21.44
	-18.8	-19	73.28	30.50	68.38	28.07	63.76	25.71	61.17	24.57	58.86	23.47	53.95	21.26
	-16.7	-17	73.28	29.88	68.38	27.52	63.76	25.24	61.17	24.09	58.86	22.99	53.95	20.85
	-13.7	-15	73.28	29.29	68.38	26.97	63.76	24.72	61.17	23.65	58.86	22.55	53.95	20.45
	-11.8	-13	73.28	28.70	68.38	26.45	63.76	24.28	61.17	23.17	58.86	22.14	53.95	20.08
	-9.8	-11	73.28	28.15	68.38	25.94	63.76	23.80	61.17	22.77	58.86	21.74	53.95	19.71
	-9.5	-10	73.28	27.89	68.38	25.71	63.76	23.58	61.17	22.55	58.86	21.51	53.95	19.56
	-8.5	-9.1	73.28	27.63	68.38	25.49	63.76	23.39	61.17	22.36	58.86	21.37	53.95	19.38
	-7	-7.6	73.28	27.26	68.38	25.13	63.76	23.06	61.17	22.07	58.86	21.07	53.95	19.12
	-5	-5.6	73.28	26.41	68.38	24.39	63.76	22.44	61.17	21.48	58.86	20.52	53.95	18.68
	-3	-3.7	73.28	27.34	68.38	25.24	63.76	23.21	61.17	22.21	58.86	21.26	53.95	19.34
	0	-0.7	73.28	28.74	68.38	26.56	63.76	24.43	61.17	23.39	58.86	22.36	53.95	20.37
	3	2.2	73.28	25.01	68.38	23.17	63.76	21.37	61.17	20.48	58.86	19.60	53.95	17.90
	5	4.1	73.28	23.10	68.38	21.51	63.76	19.93	61.17	19.16	58.86	18.38	53.95	16.87
	7	6	73.28	20.48	68.38	19.16	63.76	17.87	61.17	17.20	58.86	16.58	53.95	15.33
	9	7.9	73.28	19.60	68.38	18.42	63.76	17.28	61.17	20.41	58.86	16.14	53.95	15.03
11	9.8	73.28	18.83	68.38	17.79	63.76	16.76	61.17	16.28	58.86	15.77	53.95	14.77	
13	11.8	73.28	18.13	68.38	17.24	63.76	16.32	61.17	15.88	58.86	15.44	53.95	14.55	
15	13.7	73.28	17.65	68.38	16.84	63.76	16.06	61.17	15.66	58.86	15.25	53.95	14.48	

Обозначения:

ТС: Полная производительность (кВт)

PI: Потребляемая мощность (компрессор + двигатель вентилятора наружного блока) (кВт)

Продолжение таблицы на следующей странице...

Таблица 2-8.31: Частичная тепловая нагрузка для блоков производительностью 30 л.с. (продолжение)

Частичная нагрузка	Температура наружного воздуха (°CDB)		Температура в помещении (°C DB/WD)											
			16.0		18.0		20.0		21.0		22.0		24.0	
			ТС	PI	ТС	PI	ТС	PI	ТС	PI	ТС	PI	ТС	PI
°C DB	°C WB	кВт	кВт	кВт	кВт	кВт	кВт	кВт	кВт	кВт	кВт	кВт	кВт	
50%	-25	-25.4	49.11	19.22	45.87	17.81	42.63	16.42	40.75	17.19	39.13	15.09	35.89	13.79
	-19.8	-20	49.11	18.88	45.87	17.51	42.63	16.14	40.75	15.50	39.13	14.84	35.89	13.57
	-18.8	-19	49.11	18.71	45.87	17.34	42.63	16.00	40.75	18.68	39.13	14.70	35.89	13.43
	-16.7	-17	49.11	18.34	45.87	17.01	42.63	15.70	40.75	15.07	39.13	14.43	35.89	13.20
	-13.7	-15	49.11	18.01	45.87	16.71	42.63	15.44	40.75	14.80	39.13	14.20	35.89	12.96
	-11.8	-13	49.11	17.68	45.87	16.41	42.63	15.17	40.75	14.53	39.13	13.93	35.89	12.76
	-9.8	-11	49.11	17.37	45.87	16.14	42.63	14.90	40.75	14.30	39.13	13.70	35.89	12.53
	-9.5	-10	49.11	17.21	45.87	15.97	42.63	14.77	40.75	14.17	39.13	13.60	35.89	12.43
	-8.5	-9.1	49.11	17.07	45.87	15.87	42.63	14.67	40.75	14.07	39.13	13.50	35.89	12.36
	-7	-7.6	49.11	16.87	45.87	15.67	42.63	14.47	40.75	13.90	39.13	13.33	35.89	12.20
	-5	-5.6	49.11	16.47	45.87	15.30	42.63	14.17	40.75	13.63	39.13	13.06	35.89	12.00
	-3	-3.7	49.11	17.07	45.87	15.87	42.63	14.70	40.75	14.13	39.13	13.57	35.89	12.43
	0	-0.7	49.11	17.98	45.87	16.71	42.63	15.50	40.75	14.90	39.13	14.30	35.89	13.13
	3	2.2	49.11	15.80	45.87	14.73	42.63	13.67	40.75	13.16	39.13	12.63	35.89	11.63
	5	4.1	49.11	14.94	45.87	13.97	42.63	13.06	40.75	12.60	39.13	12.13	35.89	11.23
	7	6	49.11	13.57	45.87	12.80	42.63	12.00	40.75	11.63	39.13	11.23	35.89	10.46
	9	7.9	49.11	13.33	45.87	12.63	42.63	11.93	40.75	11.59	39.13	11.23	35.89	10.56
11	9.8	49.11	13.13	45.87	12.50	42.63	11.86	40.75	11.56	39.13	11.26	35.89	10.63	
13	11.8	49.11	12.96	45.87	12.40	42.63	11.86	40.75	11.56	39.13	11.26	35.89	10.76	
15	13.7	49.11	12.93	45.87	12.40	42.63	11.89	40.75	11.66	39.13	11.43	35.89	10.93	
25%	-25	-25.4	24.51	10.39	22.94	9.58	21.25	8.80	20.46	8.41	19.56	8.04	17.99	7.31
	-19.8	-20	24.51	10.17	22.94	9.39	21.25	8.63	20.46	8.25	19.56	7.88	17.99	7.17
	-18.8	-19	24.51	10.07	22.94	9.30	21.25	8.54	20.46	8.17	19.56	7.81	17.99	7.11
	-16.7	-17	24.51	9.87	22.94	9.11	21.25	8.38	20.46	8.01	19.56	7.66	17.99	6.98
	-13.7	-15	24.51	9.68	22.94	8.93	21.25	8.22	20.46	7.87	19.56	7.53	17.99	6.85
	-11.8	-13	24.51	9.49	22.94	8.77	21.25	8.07	20.46	7.72	19.56	7.39	17.99	6.73
	-9.8	-11	24.51	9.31	22.94	8.61	21.25	7.93	20.46	7.59	19.56	7.25	17.99	6.61
	-9.5	-10	24.51	9.23	22.94	8.52	21.25	7.85	20.46	7.52	19.56	7.20	17.99	6.55
	-8.5	-9.1	24.51	9.16	22.94	8.47	21.25	7.79	20.46	7.46	19.56	7.14	17.99	6.51
	-7	-7.6	24.51	9.02	22.94	8.35	21.25	7.69	20.46	7.37	19.56	7.05	17.99	6.42
	-5	-5.6	24.51	8.77	22.94	8.13	21.25	7.50	20.46	7.20	19.56	6.89	17.99	6.29
	-3	-3.7	24.51	9.09	22.94	8.42	21.25	7.77	20.46	7.46	19.56	7.14	17.99	6.52
	0	-0.7	24.51	9.56	22.94	8.86	21.25	8.19	20.46	7.85	19.56	7.52	17.99	6.88
	3	2.2	24.51	8.36	22.94	7.77	21.25	7.18	20.46	6.90	19.56	6.61	17.99	6.06
	5	4.1	24.51	7.81	22.94	7.28	21.25	6.77	20.46	6.52	19.56	6.28	17.99	5.78
	7	6	24.51	7.01	22.94	6.57	21.25	6.15	20.46	5.93	19.56	5.72	17.99	5.31
	9	7.9	24.51	6.79	22.94	6.39	21.25	6.01	20.46	5.82	19.56	5.65	17.99	5.27
11	9.8	24.51	6.58	22.94	6.25	21.25	5.91	20.46	5.74	19.56	5.58	17.99	5.24	
13	11.8	24.51	6.42	22.94	6.12	21.25	5.82	20.46	5.66	19.56	5.52	17.99	5.23	
15	13.7	24.51	6.32	22.94	6.04	21.25	5.78	20.46	5.65	19.56	5.52	17.99	5.24	

Обозначения:

ТС: Полная производительность (кВт)

PI: Потребляемая мощность (компрессор + двигатель вентилятора наружного блока) (кВт)

MVS FDC II-S

Таблица 2-8.32: Частичная тепловая нагрузка для блоков производительностью 32 л.с.

Частичная нагрузка	Температура наружного воздуха (°CDB)		Температура в помещении (°C DB/WD)											
			16.0		18.0		20.0		21.0		22.0		24.0	
			ТС	PI	ТС	PI	ТС	PI	ТС	PI	ТС	PI	ТС	PI
°C DB	°C WB	кВт	кВт	кВт	кВт	кВт	кВт	кВт	кВт	кВт	кВт	кВт	кВт	
100%	-25	-25.4	73.14	31.46	72.86	31.76	72.57	32.11	72.57	32.30	72.57	32.49	72.29	32.91
	-19.8	-20	73.71	31.46	73.43	31.80	73.14	32.15	73.14	32.34	73.14	32.53	72.86	32.91
	-18.8	-19	74.86	31.53	74.57	31.88	74.29	32.22	74.29	32.38	74.29	32.57	74.00	32.95
	-16.7	-17	76.00	31.57	75.71	31.92	75.71	32.26	75.43	32.45	75.43	32.65	75.14	32.26
	-13.7	-15	77.14	31.65	76.86	31.96	76.86	32.34	76.57	32.49	76.57	32.68	76.29	31.61
	-11.8	-13	78.29	31.69	78.00	32.03	78.00	32.38	77.71	32.57	77.71	32.72	76.29	31.00
	-9.8	-11	78.86	31.73	78.86	32.07	78.57	32.42	78.57	32.57	78.29	32.76	76.29	30.69
	-9.5	-10	79.43	31.76	79.14	32.07	79.14	32.42	78.86	32.61	78.86	32.80	76.29	30.42
	-8.5	-9.1	80.29	31.80	80.29	32.11	80.00	32.45	79.71	32.65	79.71	32.84	76.29	30.00
	-7	-7.6	86.57	31.84	86.29	32.12	86.29	32.47	86.00	33.84	83.14	32.19	76.29	29.04
	-5	-5.6	87.71	31.88	87.43	32.14	87.43	32.49	86.57	34.99	83.14	33.30	76.29	30.04
	-3	-3.7	89.43	31.92	89.14	32.16	89.14	31.42	86.57	32.91	83.14	34.99	76.29	31.57
	0	-0.7	91.71	31.96	96.86	32.18	90.00	30.54	86.57	34.60	83.14	32.99	76.29	29.65
	3	2.2	97.71	33.96	96.86	31.38	90.00	29.67	86.57	31.84	83.14	30.38	76.29	27.47
	5	4.1	103.71	32.20	96.86	29.85	90.00	28.27	86.57	29.08	83.14	27.77	76.29	25.28
	7	6	103.71	30.43	96.86	28.31	90.00	26.47	86.57	25.43	83.14	24.36	76.29	22.33
	9	7.9	103.71	28.70	96.86	26.82	90.00	24.94	86.57	24.01	83.14	23.09	76.29	21.29
11	9.8	103.71	26.85	96.86	25.17	90.00	23.55	86.57	22.75	83.14	21.94	76.29	20.37	
13	11.8	103.71	25.17	96.86	23.75	90.00	22.33	86.57	21.64	83.14	20.95	76.29	19.56	
15	13.7	103.71	23.94	96.86	22.71	90.00	21.44	86.57	20.83	83.14	20.22	76.29	18.99	
75%	-25	-25.4	77.11	34.33	72.40	31.57	67.51	28.92	64.76	27.62	62.32	26.35	57.13	23.85
	-19.8	-20	76.98	33.62	72.40	30.93	67.51	28.36	64.76	27.07	62.32	25.83	57.13	23.38
	-18.8	-19	77.60	33.26	72.40	30.60	67.51	28.03	64.76	26.79	62.32	25.58	57.13	23.17
	-16.7	-17	77.60	32.57	72.40	30.00	67.51	27.51	64.76	26.27	62.32	25.06	57.13	22.73
	-13.7	-15	77.60	31.93	72.40	29.40	67.51	26.95	64.76	25.78	62.32	24.58	57.13	22.29
	-11.8	-13	77.60	31.29	72.40	28.84	67.51	26.47	64.76	25.26	62.32	24.14	57.13	21.89
	-9.8	-11	77.60	30.68	72.40	28.28	67.51	25.95	64.76	24.82	62.32	23.70	57.13	21.49
	-9.5	-10	77.60	30.40	72.40	28.03	67.51	25.70	64.76	24.58	62.32	23.46	57.13	21.33
	-8.5	-9.1	77.60	30.12	72.40	27.79	67.51	25.50	64.76	24.38	62.32	23.29	57.13	21.13
	-7	-7.6	77.60	29.72	72.40	27.39	67.51	25.14	64.76	24.06	62.32	22.97	57.13	20.84
	-5	-5.6	77.60	28.80	72.40	26.59	67.51	24.46	64.76	23.42	62.32	22.37	57.13	20.36
	-3	-3.7	77.60	29.80	72.40	27.51	67.51	25.30	64.76	24.22	62.32	23.17	57.13	21.09
	0	-0.7	77.60	31.33	72.40	28.96	67.51	26.63	64.76	25.50	62.32	24.38	57.13	22.21
	3	2.2	77.60	27.27	72.40	25.26	67.51	23.29	64.76	22.33	62.32	21.37	57.13	19.52
	5	4.1	77.60	25.18	72.40	23.46	67.51	21.73	64.76	20.88	62.32	20.04	57.13	18.39
	7	6	77.60	22.33	72.40	20.88	67.51	19.48	64.76	18.76	62.32	18.07	57.13	16.71
	9	7.9	77.60	21.37	72.40	20.08	67.51	18.84	64.76	22.25	62.32	17.59	57.13	16.39
11	9.8	77.60	20.52	72.40	19.40	67.51	18.27	64.76	17.75	62.32	17.19	57.13	16.11	
13	11.8	77.60	19.76	72.40	18.80	67.51	17.79	64.76	17.31	62.32	16.83	57.13	15.86	
15	13.7	77.60	19.24	72.40	18.35	67.51	17.51	64.76	17.07	62.32	16.63	57.13	15.78	

Обозначения:

ТС: Полная производительность (кВт)

PI: Потребляемая мощность (компрессор + двигатель вентилятора наружного блока) (кВт)

Продолжение таблицы на следующей странице...

Таблица 2-8.32: Частичная тепловая нагрузка для блоков производительностью 32 л.с. (продолжение)

Частичная нагрузка	Температура наружного воздуха (°CDB)		Температура в помещении (°C DB/WD)											
			16.0		18.0		20.0		21.0		22.0		24.0	
			ТС	PI	ТС	PI	ТС	PI	ТС	PI	ТС	PI	ТС	PI
°C DB	°C WB	кВт	кВт	кВт	кВт	кВт	кВт	кВт	кВт	кВт	кВт	кВт	кВт	
50%	-25	-25.4	52.00	20.96	48.57	19.42	45.14	17.91	43.14	18.74	41.43	16.45	38.00	15.03
	-19.8	-20	52.00	20.58	48.57	19.09	45.14	17.59	43.14	16.90	41.43	16.17	38.00	14.79
	-18.8	-19	52.00	20.40	48.57	18.91	45.14	17.45	43.14	20.36	41.43	16.03	38.00	14.64
	-16.7	-17	52.00	20.00	48.57	18.54	45.14	17.12	43.14	16.43	41.43	15.74	38.00	14.39
	-13.7	-15	52.00	19.63	48.57	18.21	45.14	16.83	43.14	16.14	41.43	15.48	38.00	14.13
	-11.8	-13	52.00	19.27	48.57	17.89	45.14	16.54	43.14	15.85	41.43	15.19	38.00	13.91
	-9.8	-11	52.00	18.94	48.57	17.59	45.14	16.25	43.14	15.59	41.43	14.93	38.00	13.66
	-9.5	-10	52.00	18.76	48.57	17.41	45.14	16.10	43.14	15.44	41.43	14.83	38.00	13.55
	-8.5	-9.1	52.00	18.61	48.57	17.30	45.14	15.99	43.14	15.34	41.43	14.72	38.00	13.48
	-7	-7.6	52.00	18.40	48.57	17.08	45.14	15.77	43.14	15.15	41.43	14.53	38.00	13.30
	-5	-5.6	52.00	17.96	48.57	16.68	45.14	15.44	43.14	14.86	41.43	14.24	38.00	13.08
	-3	-3.7	52.00	18.61	48.57	17.30	45.14	16.03	43.14	15.41	41.43	14.79	38.00	13.55
	0	-0.7	52.00	19.60	48.57	18.21	45.14	16.90	43.14	16.25	41.43	15.59	38.00	14.32
	3	2.2	52.00	17.23	48.57	16.06	45.14	14.90	43.14	14.35	41.43	13.77	38.00	12.68
	5	4.1	52.00	16.28	48.57	15.23	45.14	14.24	43.14	13.73	41.43	13.22	38.00	12.24
	7	6	52.00	14.79	48.57	13.95	45.14	13.08	43.14	12.68	41.43	12.24	38.00	11.40
	9	7.9	52.00	14.53	48.57	13.77	45.14	13.00	43.14	12.64	41.43	12.24	38.00	11.51
11	9.8	52.00	14.32	48.57	13.62	45.14	12.93	43.14	12.60	41.43	12.28	38.00	11.58	
13	11.8	52.00	14.13	48.57	13.51	45.14	12.93	43.14	12.60	41.43	12.28	38.00	11.73	
15	13.7	52.00	14.10	48.57	13.51	45.14	12.97	43.14	12.71	41.43	12.46	38.00	11.91	
25%	-25	-25.4	25.95	11.33	24.29	10.44	22.50	9.59	21.67	9.17	20.71	8.77	19.05	7.97
	-19.8	-20	25.95	11.09	24.29	10.23	22.50	9.40	21.67	8.99	20.71	8.59	19.05	7.81
	-18.8	-19	25.95	10.98	24.29	10.14	22.50	9.31	21.67	8.91	20.71	8.51	19.05	7.75
	-16.7	-17	25.95	10.76	24.29	9.93	22.50	9.13	21.67	8.74	20.71	8.35	19.05	7.61
	-13.7	-15	25.95	10.55	24.29	9.74	22.50	8.96	21.67	8.58	20.71	8.21	19.05	7.46
	-11.8	-13	25.95	10.34	24.29	9.56	22.50	8.80	21.67	8.42	20.71	8.05	19.05	7.34
	-9.8	-11	25.95	10.15	24.29	9.39	22.50	8.64	21.67	8.28	20.71	7.91	19.05	7.21
	-9.5	-10	25.95	10.06	24.29	9.29	22.50	8.56	21.67	8.20	20.71	7.85	19.05	7.15
	-8.5	-9.1	25.95	9.99	24.29	9.23	22.50	8.50	21.67	8.13	20.71	7.78	19.05	7.10
	-7	-7.6	25.95	9.83	24.29	9.10	22.50	8.39	21.67	8.04	20.71	7.69	19.05	7.00
	-5	-5.6	25.95	9.56	24.29	8.86	22.50	8.18	21.67	7.85	20.71	7.51	19.05	6.86
	-3	-3.7	25.95	9.91	24.29	9.18	22.50	8.47	21.67	8.13	20.71	7.78	19.05	7.11
	0	-0.7	25.95	10.42	24.29	9.66	22.50	8.93	21.67	8.56	20.71	8.20	19.05	7.50
	3	2.2	25.95	9.12	24.29	8.47	22.50	7.83	21.67	7.53	20.71	7.21	19.05	6.60
	5	4.1	25.95	8.51	24.29	7.94	22.50	7.38	21.67	7.11	20.71	6.84	19.05	6.30
	7	6	25.95	7.64	24.29	7.16	22.50	6.70	21.67	6.46	20.71	6.24	19.05	5.79
	9	7.9	25.95	7.40	24.29	6.97	22.50	6.56	21.67	6.35	20.71	6.16	19.05	5.74
11	9.8	25.95	7.18	24.29	6.81	22.50	6.44	21.67	6.25	20.71	6.08	19.05	5.71	
13	11.8	25.95	7.00	24.29	6.67	22.50	6.35	21.67	6.17	20.71	6.02	19.05	5.70	
15	13.7	25.95	6.89	24.29	6.59	22.50	6.30	21.67	6.16	20.71	6.02	19.05	5.71	

Обозначения:

ТС: Полная производительность (кВт)

PI: Потребляемая мощность (компрессор + двигатель вентилятора наружного блока) (кВт)

9. Диапазон рабочих температур

Рисунок 2-9.1: Диапазон рабочих температур в режиме охлаждения



Рисунок 2-9.2: Диапазон рабочих температур в режиме обогрева



Примечание:

1. Данные технические характеристики приведены для эксплуатации в следующих условиях:
 - Эквивалентная длина трубопровода: 7,5 м
 - Перепад высот: 0

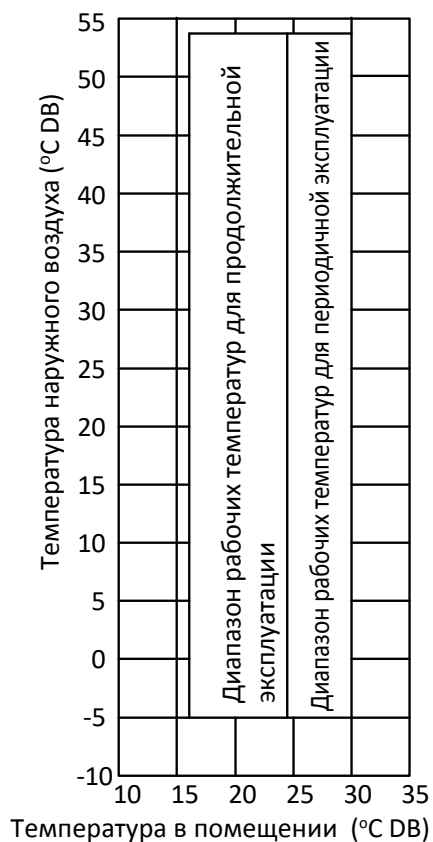
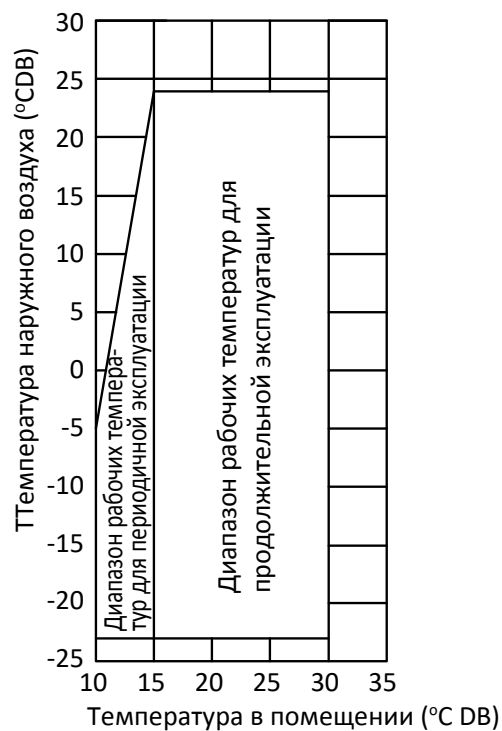
10. Уровень звукового давления

10.1 Общие уровни звукового давления

Таблица 2-10.1: Уровни звукового давления

Модель	дБ(А)
18 л.с	62
20 л.с	63
22 л.с	63
24 л.с	64
26 л.с	64
28 л.с	64
30 л.с	64
32 л.с	64

Примечание:

1. Значения звукового давления измерены в полубезэховой лаборатории на расстоянии 1 м от фронтальной стороны блока и 1,3 м от пола. При фактической эксплуатации уровень звукового давления может быть выше в результате воздействия постороннего шума.

Рисунок 2-10.1: Измерение уровня звукового давления (Единица измерения: мм)

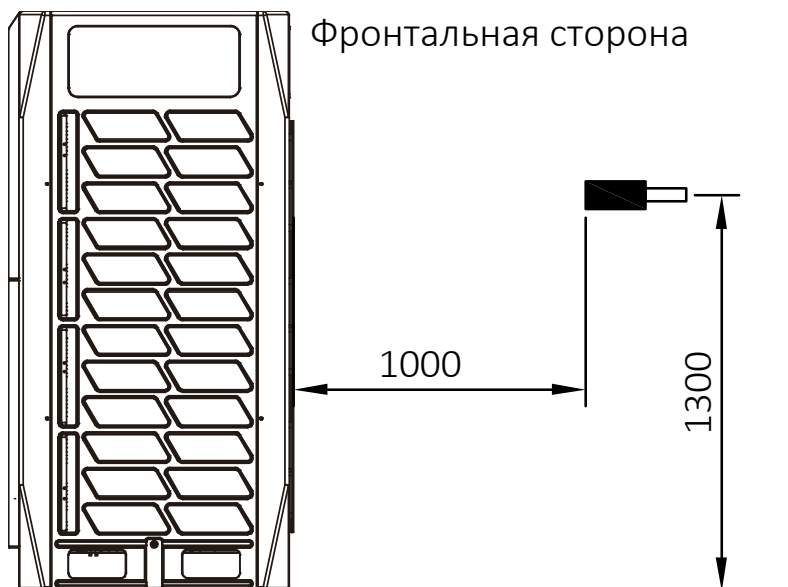

Измерение уровней звукового давления в октавных полосах частот

Рисунок 2-10.5 Измерение уровней звукового давления для блоков производительностью 18 л.с.



Рисунок 2-10.6 Измерение уровней звукового давления для блоков производительностью 20/22 л.с.







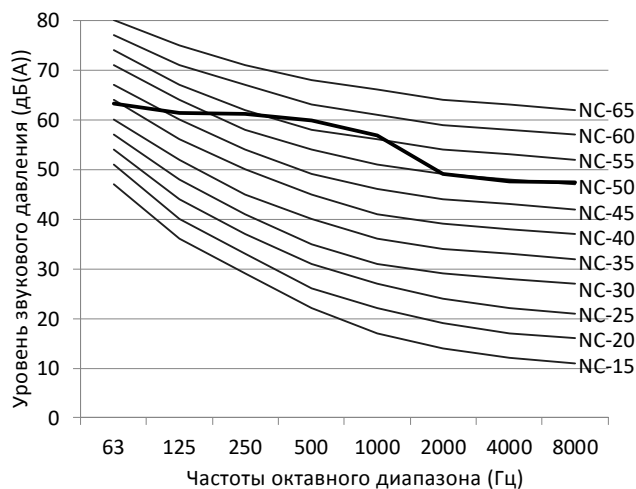

Рисунок 2-10.7 Измерение уровней звукового давления для блоков производительностью 24/26/28/30/32 л.с.

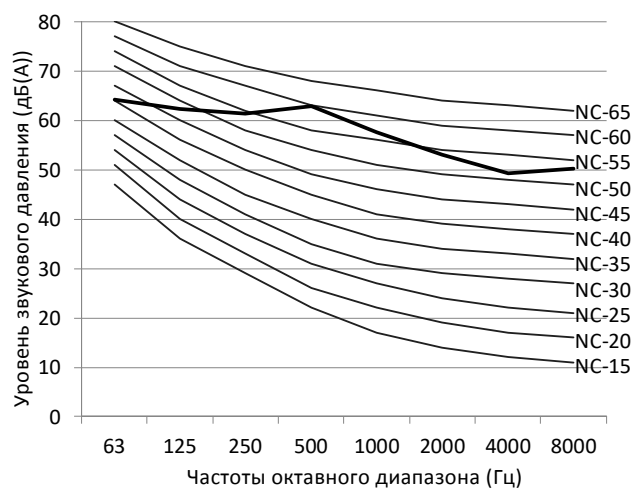
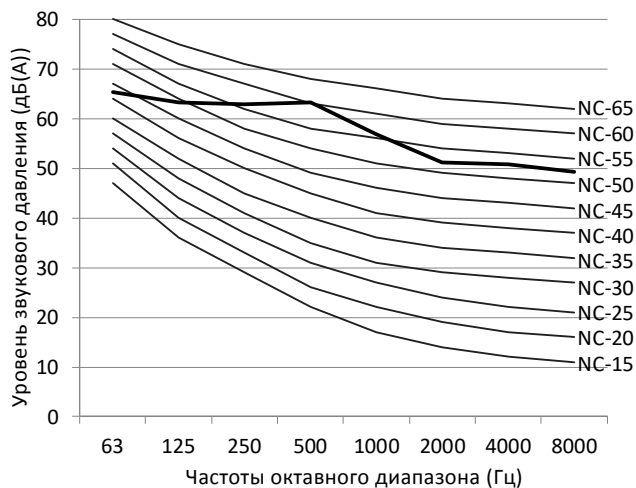

11. Принадлежности

11.1 Стандартные принадлежности

Таблица 2-11.1: Стандартные принадлежности

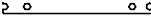
Наименование	Внешний вид	Количество	Функция
Руководство по монтажу наружного блока		1	
Руководство по эксплуатации наружного блока		1	
Руководство по эксплуатации внутреннего блока		2	
Плоская отвертка	-	1	Регулировка DIP- переключателей внутреннего и наружного блоков
90° угольник		1	Для соединения трубопроводов
Уплотняющая пробка		8	Для сохранения чистоты труб
Соединительный трубопровод		3	Для соединения трубопроводов
Согласующий резистор		2	Для стабилизации связи
Гаечный ключ		1	Для снятия боковой панели
Упаковка для принадлежностей	-	1	

11.2 Опциональные принадлежности

Таблица 2-11.2: Опциональные принадлежности

Опциональные принадлежности	Модель	Габаритные размеры в упаковке(мм)	Вес без упаковки/ Вес в упаковке (кг)	Функция
Разветвители для внутренних блоков	MD-ZHN01E	290×105×100	0,3 / 0,4	Распределение хладагента между внутренними блоками и уравнивание потерь между наружными блоками
	MD-ZHN02E	290×105×100	0,4 / 0,6	
	MD-ZHN03E	310×130×125	0,6 / 0,9	
	MD-ZHN04E	350×170×180	1,1 / 1,5	

Часть 3

Проектирование и МОНТАЖ СИСТЕМЫ

1.	Предисловие к Части 3	135
2.	Монтаж блока	136
3.	Монтаж воздухопроводов для наружных блоков	139
4.	Проектирование трубопроводов хладагента	144
5.	Монтаж трубопровода хладагента	153
6.	Монтаж дренажных трубопроводов	164
7.	Теплоизоляция	167
8.	Заправка дополнительного количества хладагента	169
9.	Монтаж электрических соединений	171
10.	Монтаж в местах с высокой концентрацией солей в воздухе	174
11.	Пусконаладочные работы для ввода в эксплуатацию	175
12.	Приложение к Части 3 - Отчет о пусконаладочных работах	177

1. Предисловие к Части 3

1.1 Примечания для специалистов по монтажу

Информация, содержащаяся в данном техническом руководстве, предназначена для использования на этапе проектирования системы VRFсерии Dantex FDC II-S. Дополнительная информация, которая может пригодиться на этапе монтажа, помещена в рамку, как, например, в приведенном ниже примере под названием «Примечания для специалистов по монтажу».

Примечания для специалистов по монтажу

- В данных примечаниях содержится информация, которая может пригодиться непосредственно на этапе монтажа в отличие от этапа проектирования.

1.2 Определения

Термин «действующее законодательство» относится ко всем государственным, местным и другим законам, стандартам, кодексам, правилам, положениям и законодательным актам, которые имеют силу в отношении случаев, приведённых в настоящем руководстве.

1.3 Меры технической безопасности

Все виды работ по монтажу, включая монтаж трубопроводов и электромонтаж, должны осуществляться исключительно квалифицированными и авторизованными специалистами по монтажу в соответствии с действующим законодательством.

2. Монтаж блока

2.1 Наружные блоки

2.1.1 Выбор места для монтажа

При выборе места для монтажа наружного блока обратите особое внимание на следующие пункты:

- Убедитесь, что наружный блок установлен в месте, защищенном от прямого воздействия высокой температуры от источников тепла.
- Не устанавливайте наружный блок в месте с повышенной концентрацией пыли и загрязнений во избежание их попадания в теплообменник наружного блока.
- Не устанавливайте наружный блок в месте с концентрацией масла или вредных газов, например, кислых или щелочных газов.
- Не устанавливайте наружный блок в месте с высокой концентрацией солей в воздухе, пока не приняты соответствующие меры безопасности, описанные в Части 3, п. 10 «Монтаж в местах с высокой концентрацией солей в воздухе». Исключение составляют модели с антикоррозионными свойствами.
- Убедитесь, что наружный блок установлен в сухом, хорошо проветриваемом месте, расположенном как можно ближе к внутреннему блоку.

2.1.2 Пространство для монтажа

Обеспечьте достаточное пространство вокруг наружных блоков для монтажа и осуществления технического обслуживания. Для обеспечения достаточной производительности наружных блоков необходимо обеспечить свободную циркуляцию воздуха вокруг теплообменников. На Рисунках 3-2.1 - 3-2.3 изображены три различных варианта размещения блоков относительно друг друга и окружающих их объектов.

Когда наружный блок располагается ниже окружающих его объектов (см. Рисунки 3-2.1 - 3-2.3), во избежание пересечения нагретых потоков воздуха от наружных блоков, которые могут неблагоприятно влиять на эффективность теплообменного процесса, пожалуйста, установите перегородку между наружными блоками для отвода тепла. См. Часть 3, п. 3 «Монтаж воздухопроводов для наружных блоков».

Рисунок 3-2.1: Монтаж одиночного блока (Единица измерения: мм)



Рисунок 3-2.2: Монтаж блоков в один ряд (Единица измерения: мм)



Рисунок 3-2.3: Монтаж блоков в несколько рядов (Единица измерения: мм)

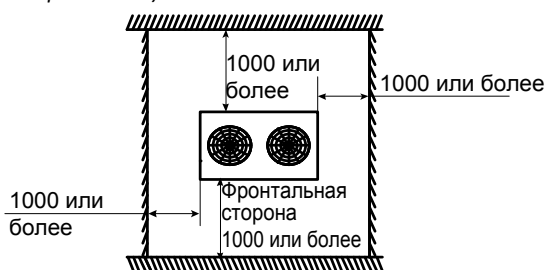

2.1.3 Монтажное основание

При подготовке монтажного основания наружного блока обратите особое внимание на следующие пункты:

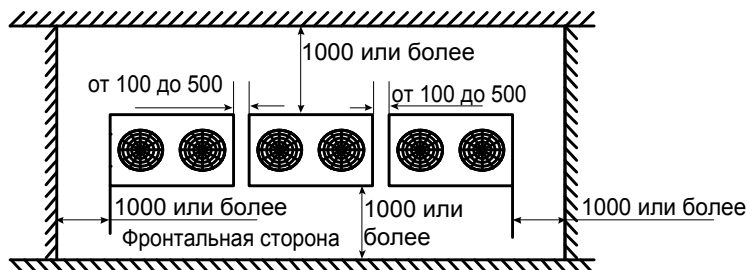
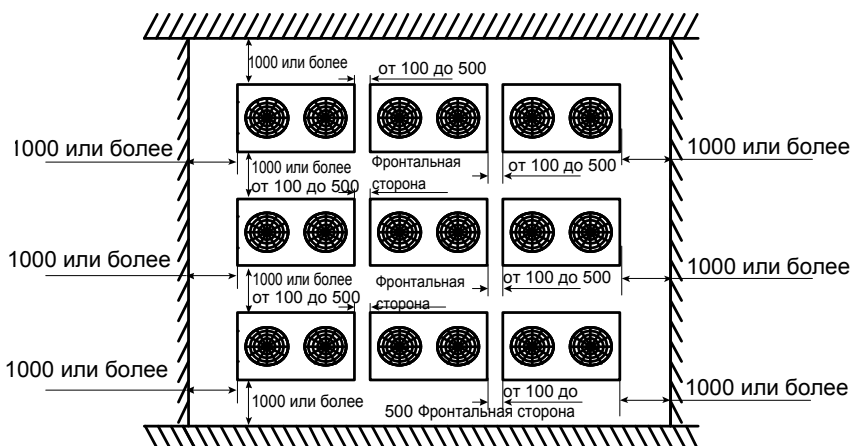
- Прочное основание способно предотвратить смещение наружного блока и снизить уровень шума, создаваемого блоком в результате недостаточно прочной фиксации на основании. Устанавливайте блок на ровной поверхности, способной выдержать его вес во время работы, при этом поверхность должна обеспечивать горизонтальное положение блока, таким образом, уровень шума и вибрации будут минимальными.
- При прокладывании трубопровода из нижней части блока высота основания должна быть не менее 200 мм.
- Устанавливайте блок на основании со стальной конструкцией или бетонном основании.
- Стандартное бетонное основание показано на Рисунке 3-2.4. Стандартный состав бетонного основания: цемент 1 часть, песок 2 части, щебень 4 части, а также стальная арматура 10 мм. Поверхность раствора цемента и песка должна быть ровной, обеспечьте углы скоса кромки основания.
- Перед изготовлением основания блока, пожалуйста, убедитесь, что оно строго вертикальное и поддерживает непосредственно задний и фронтальный края загнутой кромки нижней панели, так как данные края являются точками фактической опоры блока. Расположение крепежных болтов показано на Рисунке 3-2.5 и в Таблице 3-2.1.
- Для слива конденсата, образуемого на теплообменниках блока при его работе в режиме обогрева и скапливаемого вокруг агрегата, обеспечьте специальную канавку вокруг основания. Убедитесь, что отвод конденсата осуществляется в должном направлении на достаточном расстоянии от дорог и пешеходных тротуаров, не создавая угрозы для безопасности в результате обмерзания в холодное время года.

Рисунок 3-2.4: Конструкция стандартного бетонного основания наружного блока (Единица измерения: мм)



Рисунок 3-2.5: Изображение расположения крепежных болтов



Таблица 3-2.1: Расстояния между крепежными болтами

Размер (мм)	8-12 л.с.	14-22 л.с.	24-32 л.с.
A	740	1090	1480
B	990	1340	1730
C	723	723	723
D	790	790	790

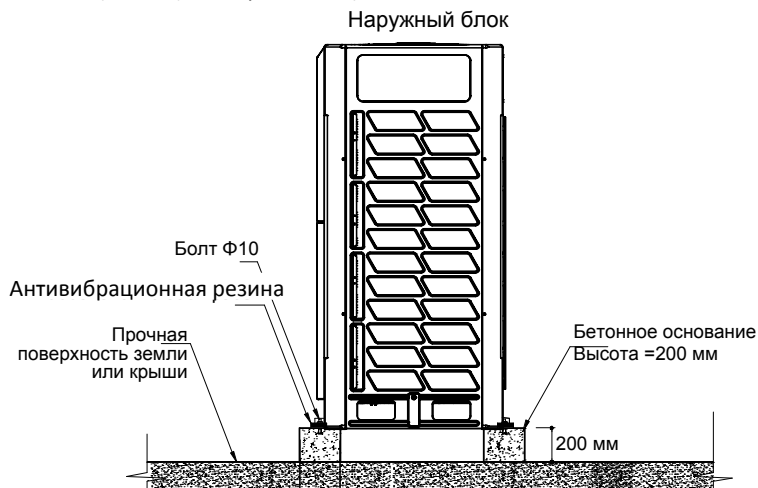
2.1.4 Приемка и распаковка наружного блока

Примечания для специалистов по монтажу

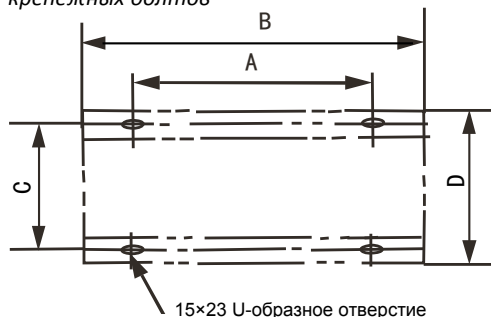
- После доставки груза проверьте его на наличие возможных повреждений, нанесенных во время транспортировки. При обнаружении каких-либо повреждений корпуса или внутренних частей агрегата незамедлительно направьте отчет в письменном виде в транспортную компанию, осуществлявшую доставку груза.
- Убедитесь, что модель, технические характеристики и количество агрегатов соответствуют условиям договора.
- После извлечения агрегата из внешней упаковки сохраните инструкции по эксплуатации и пересчитайте принадлежности.

2.1.5 Подъем наружного блока

Примечания для специалистов по монтажу

- Не снимайте упаковочные материалы с блока до его подъема. Если блок не упакован или упаковка повреждена, используйте деревянные бруски или упаковочный материал для обеспечения защиты блока.
- Во время подъема и подвески наружного блока держите его в вертикальном положении и убедитесь, что угол подъема не превышает 30°, примите все необходимые меры технической безопасности.

2.2 Внутренние блоки

2.2.1 Выбор места для монтажа

При выборе места для монтажа внутреннего блока обратите особое внимание на следующие пункты:

- Во время монтажа внутреннего блока убедитесь в наличии достаточного запаса по высоте для размещения дренажного трубопровода.
- Избегайте рециркуляции воздуха с выхода внутреннего блока на вход по кратчайшему пути для обеспечения достаточной производительности внутреннего блока при охлаждении или нагреве.
- Анкеры и шпильки должны быть достаточно прочными, чтобы выдерживать двойной вес внутреннего блока и обеспечивать защиту от шума и вибраций во время эксплуатации блока.

Примечания для специалистов по монтажу

- Перед монтажом внутреннего блока проверьте его исходные данные, убедитесь в соответствии модели указанным техническим характеристикам и инструкциям по монтажу блока.
- Убедитесь, что блок установлен на необходимой высоте.
- Обеспечьте горизонтальное расположение блока с отклонением не более $\pm 1^\circ$ для его надежной фиксации во избежание шума и вибрации во время эксплуатации, а также для обеспечения свободного слива конденсата из блока. В противном случае возможны утечки конденсата и повышенные уровни шума и вибрации во время работы блока.

3. Монтаж воздуховодов для наружных блоков

3.1 Основание для монтажа воздухонаправляющей перегородки между наружными блоками

Когда наружный блок располагается ниже окружающих его объектов, во избежание пересечения нагретых потоков воздуха от наружных блоков, которые могут неблагоприятно влиять на эффективность теплообменного процесса, пожалуйста, установите перегородку между наружными блоками для отвода тепла. Высота воздухонаправляющей перегородки $H-h$ показана на Рисунке 3-3.1.

Рисунок 3-3.1: Расстояния при расположении наружного блока ниже окружающих его объектов

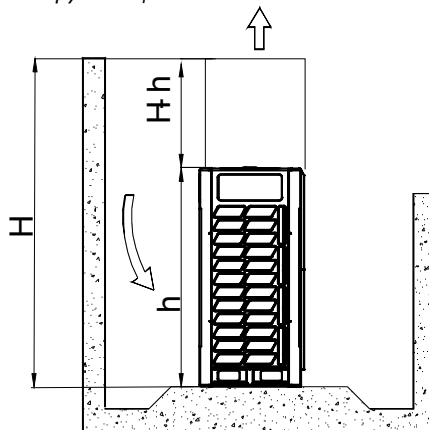

3.2 Проектирование воздуховодов

При проектировании воздуховодов наружного блока обратите особое внимание на следующие пункты:

- Воздуховод не должен иметь более одного изгиба.
- Установите гибкую муфту между блоком и воздуховодом во избежание шума и вибраций.
- При необходимости установки жалюзи учитывайте, что угол открытия при этом не должен превышать 15° , в обратном случае может быть снижен расход воздуха.

MVS FDC II-S

3.3 Монтаж воздуховодов для наружных блоков производительностью 18 л.с.

3.3.1 Вариант А – Поперечный воздуховод

Рисунок 3-3.4: Поперечный воздуховод для наружных блоков производительностью 18 л.с. (Единица измерения: мм)



Таблица 3-3.5: Габаритные размеры воздуховода

Габаритные размеры (мм)	
A	$A \geq 300$
B	$B \geq 250$
C	$C \leq 3000$
D	$770 \leq D \leq 800$
E	$E = A + 770$
θ	$\theta \leq 15^\circ$

Таблица 3-3.6: Внешнее статическое давление

ESP (Па)	Примечания
0	Заводские настройки по умолчанию
0 – 20	Снимите защитную решетку с верхней крышки и подсоедините воздуховод длиной менее 3 м.
> 20	Устанавливается пользователем

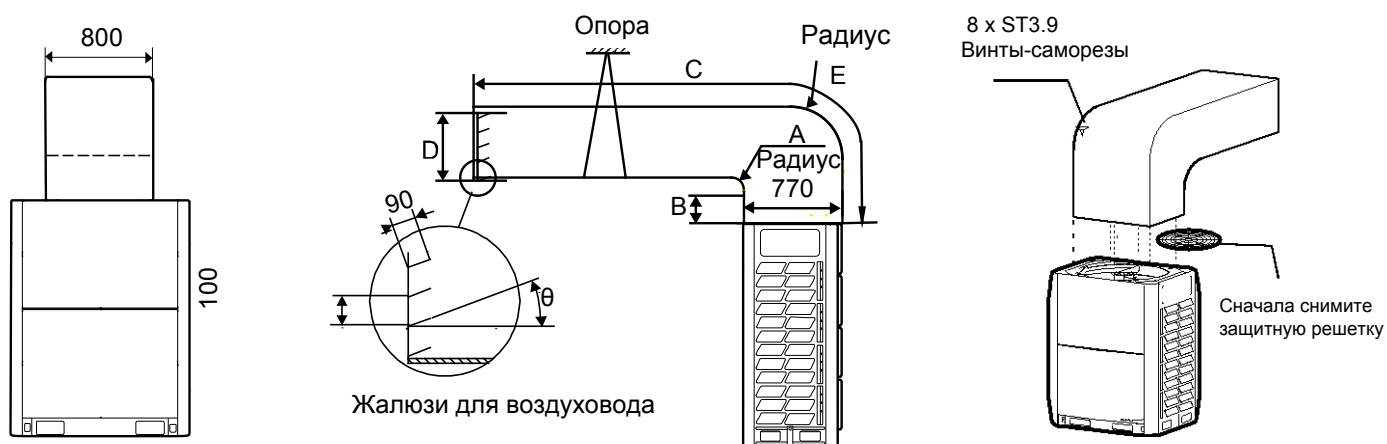
3.3.2 Вариант В – Продольный воздуховод

Рисунок 3-3.5: Продольный воздуховод для наружных блоков производительностью 18 л.с. (Единица измерения: мм)



Таблица 3-3.7: Габаритные размеры воздуховода

Габаритные размеры (мм)	
A	$A \geq 300$
B	$B \geq 250$
C	$C \leq 3000$
D	$D \geq 1290$
E	$E = A + 1290$
θ	$\theta \leq 15^\circ$

Таблица 3-3.8: Внешнее статическое давление

ESP (Па)	Примечания
0	Заводские настройки по умолчанию
0 – 20	Снимите защитную решетку с верхней крышки и подсоедините воздуховод длиной менее 3 м.
> 20	Устанавливается пользователем

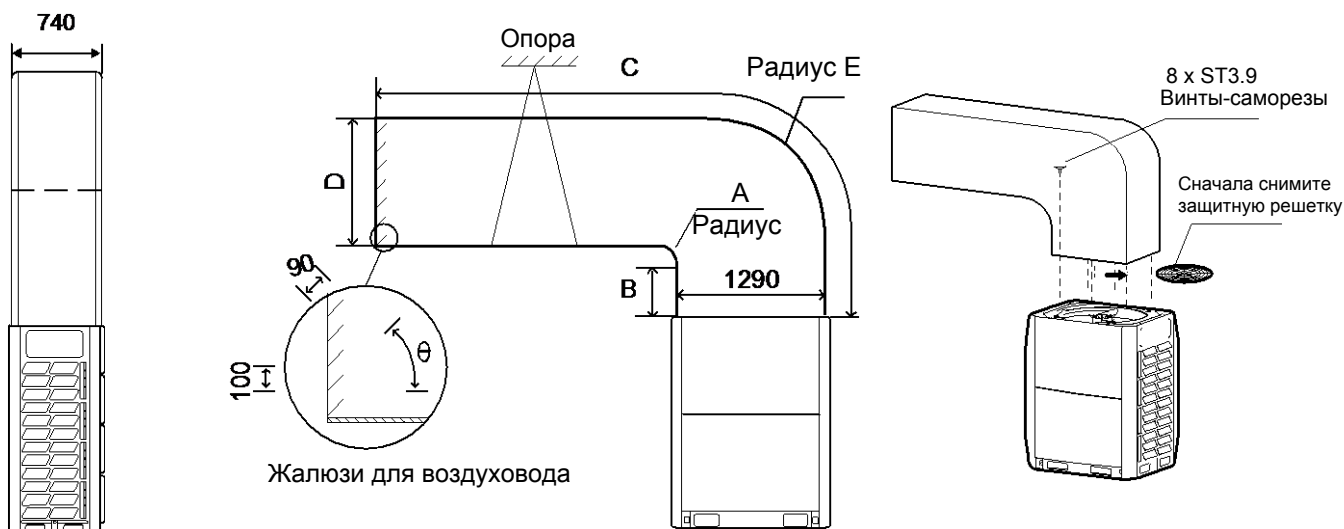
Монтаж воздухопроводов для наружных блоков производительностью 20 л.с. и 22 л.с.

3.3.3 Вариант А – Поперечный воздуховод

Рисунок 3-3.6: Поперечный воздуховод для наружных блоков производительностью 20 л.с. и 22 л.с. (Единица измерения: мм)



Таблица 3-3.9: Габаритные размеры воздуховода

Габаритные размеры (мм)	
A	$A \geq 300$
B	$B \geq 250$
C	$C \leq 3000$
D	$630 \leq D \leq 660$
E	$E = A + 630$
θ	$\theta \leq 15^\circ$

Таблица 3-3.10: Внешнее статическое давление

ESP (Па)	Примечания
0	Заводские настройки по умолчанию
0 – 20	Снимите защитную решетку с верхней крышки и подсоедините воздуховод длиной менее 3 м.
> 20	Устанавливается пользователем

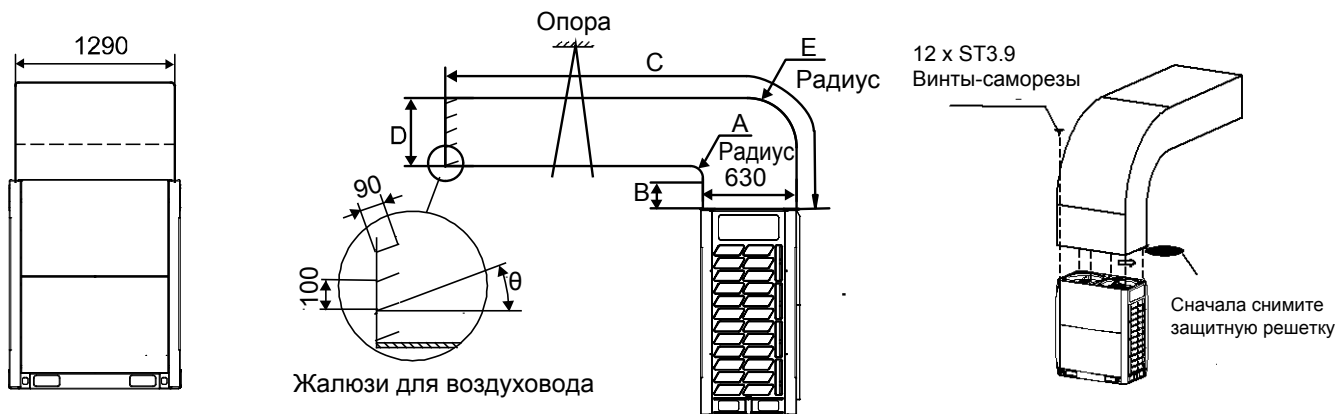
3.3.4 Вариант В – Продольный воздуховод

Рисунок 3-3.7: Продольный воздуховод для наружных блоков производительностью 20 л.с. и 22 л.с. (Единица измерения: мм)



Таблица 3-3.11: Габаритные размеры воздуховода

Габаритные размеры (мм)	
A	$A \geq 300$
B	$B \geq 250$
C	$C \leq 3000$
D	$D \geq 1290$
E	$E = A + 1290$
θ	$\theta \leq 15^\circ$

Таблица 3-3.12: Внешнее статическое давление

ESP (Па)	Примечания
0	Заводские настройки по умолчанию
0 – 20	Снимите защитную решетку с верхней крышки и подсоедините воздуховод длиной менее 3 м.
> 20	Устанавливается пользователем

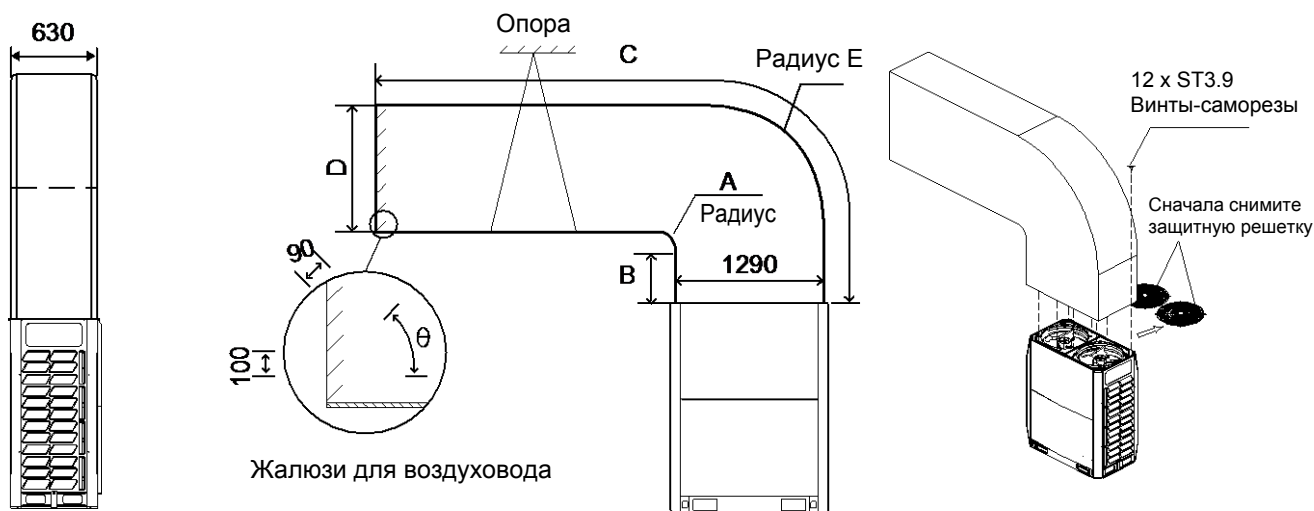
MVS FDC II-S

Монтаж воздуховодов для наружных блоков производительностью 24 л.с., 26 л.с., 28 л.с., 30 л.с. и 32 л.с.

3.3.5 Только поперечный воздуховод

Рисунок 3-3.8: Поперечный воздуховод для наружных блоков производительностью 24 л.с., 26 л.с., 28 л.с., 30 л.с. и 32 л.с. (Единица измерения: мм)



Таблица 3-3.13: Габаритные размеры воздуховода

Габаритные размеры (мм)	
A	$A \geq 300$
B	$B \geq 250$
C	$C \leq 3000$
D	$740 \leq D \leq 770$
E	$E = A + 740$
θ	$\theta \leq 15^\circ$

Таблица 3-3.14: Внешнее статическое давление

ESP (Па)	Примечания
0	Заводские настройки по умолчанию
0 – 20	Снимите защитную решетку с верхней крышки и подсоедините воздуховод длиной менее 3 м.
> 20	Устанавливается пользователем

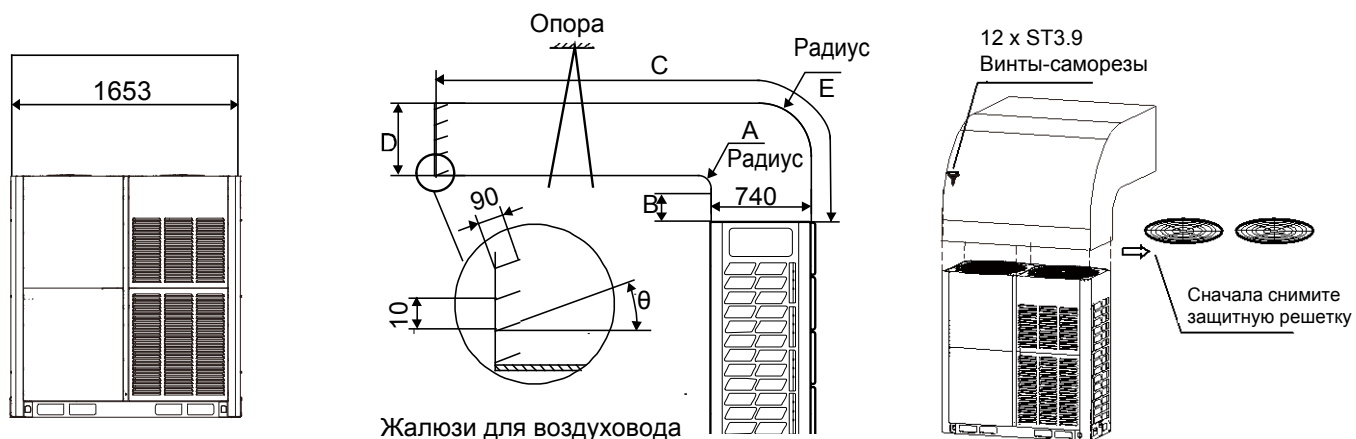
3.4 Производительность вентилятора наружного блока

Статическое давление наружного блока по умолчанию 0 Па, при снятии защитной решетки достигается давление до 20 Па.

Рисунок 3-3.10: Производительность вентилятора наружного блока 18 л.с.



Рисунок 3-3.11: Производительность вентилятора наружного блока 20-22 л.с.



Рисунок 3-3.12: Производительность вентилятора наружного блока 24-28 л.с.

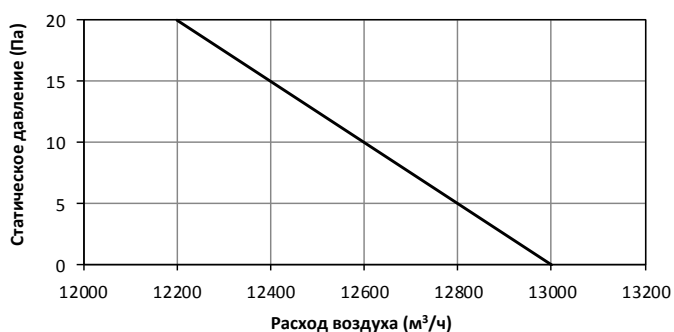

Рисунок 3-3.13: Производительность вентилятора наружного блока 30-32 л.с.

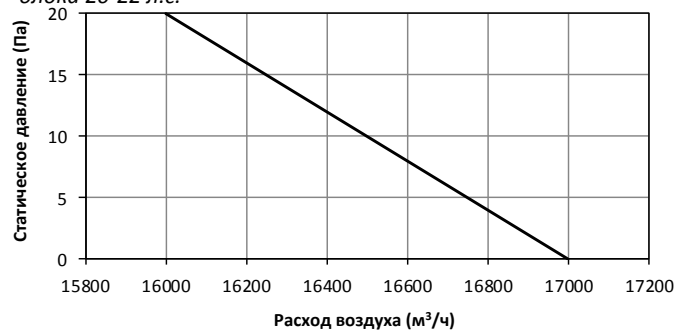

Примечания для специалистов по монтажу

- До начала монтажа воздуховодов, пожалуйста, снимите защитную решетку, в противном случае может быть снижен расход воздуха.

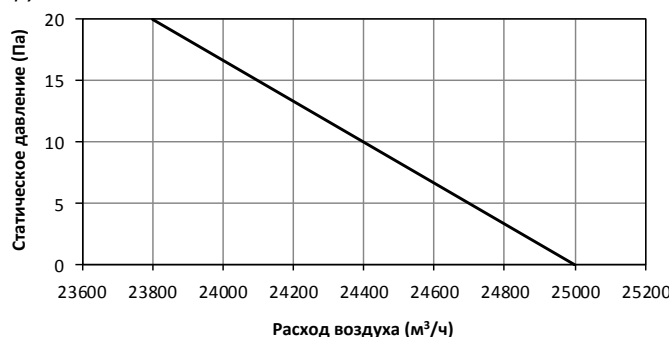
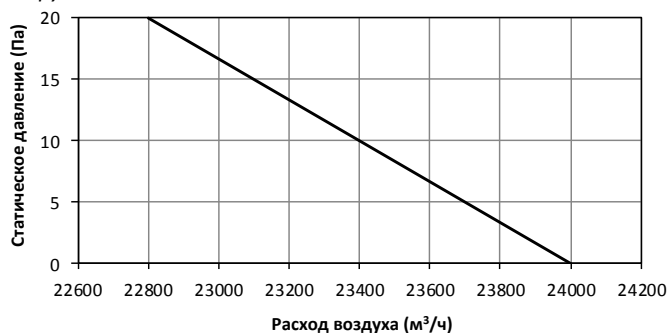
3.5 Защита от снега

В регионах, где возможно выпадение снега в зимний период, необходимо предусмотреть установку специальных принадлежностей на входе и выходе воздуха для защиты блока от попадания в него снега. Также, высота основания должна быть увеличена, чтобы блок располагался на достаточном расстоянии от земли.

Рисунок 3-3.14: Защита наружного блока от снега

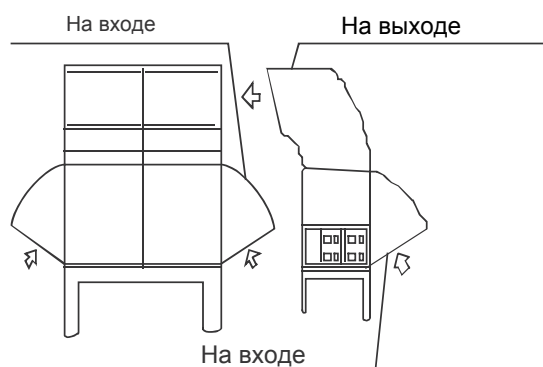

4. Проектирование трубопроводов хладагента

4.1 Процесс проектирования трубопроводов хладагента

При проектировании трубопроводов хладагента обратите особое внимание на следующие пункты:

- Пайка должна осуществляться только при необходимости и как можно реже, и количество швов должно быть минимальным.
- По возможности внутренние блоки должны быть установлены равными по количеству, производительности, общей длине трубопроводов по обе стороны U-образного разветвителя (разветвителя «А» на Рисунках 3-4.2, 3-4.3 и 3-4.4).

4.2 Материал трубопроводов

Следует использовать только бесшовные, бескислородные медные трубы, которые соответствуют всем требованиям действующего законодательства. Марки отпуска и минимальная толщина для разных диаметров трубопровода указаны в Таблице 3-4.1.

Таблица 3-4.1: Марки отпуска и минимальная толщина

Наружный диаметр трубы (мм)	Марки отпуска ¹	Минимальная толщина (мм)
Ф6,35	О (Отожженная)	0,8
Ф9,53		0,8
Ф12,7		0,8
Ф15,9		1,0
Ф19,1		1,0
Ф22,2	1/2Н (Полутвердая)	1,2
Ф25,4		1,2
Ф28,6		1,3
Ф31,8		1,5
Ф38,1		1,5
Ф41,3		1,5
Ф44,5		1,5
Ф54,0	1,8	

Примечания:

1. О: бухта; 1/2Н: прямой трубопровод.

4.3 Допустимые значения длин трубопроводов хладагента и перепада высот между блоками

Длина трубопровода и перепад высот представлены в Таблице 3-4.3 и детально описаны ниже (См. Рисунок 3-4.2):

- Требование 1:** Общая длина трубопровода в одной системе хладагента не должна превышать 1000 м. При расчете общей длины трубопровода учитывайте, что фактическая длина трубопроводов с учетом разветвителей (длина трубопроводов L2 - L9 между первым и последним разветвителями) должна быть увеличена в два раза.
- Требование 2:** Длина трубопровода от наружного блока до самого дальнего внутреннего блока (N10) не должна превышать 175 м (фактическая длина) и 200 м (эквивалентная длина). (Эквивалентная длина каждого разветвителя 0,5 м).
- Требование 3:** Длина трубопровода от первого разветвителя (A) до самого дальнего внутреннего блока (N10) не должна превышать 40 м ($L5 + L8 + L9 + j \leq 40$ м), но при выполнении следующих условий допустимая длина может быть увеличена до 90 м:

Условия:

- Длина каждого дополнительного трубопровода (от каждого внутреннего блока до ближайшего разветвителя) не превышает 20 м ($a - m \leq 20$ м).
- Перепад высот между {участком от первого разветвителя (A) до самого дальнего внутреннего блока (N10)} и {участком от первого разветвителя (A) до ближайшего внутреннего блока (N1)} не превышает 40 м. Таким образом: $(L5 + L8 + L9 + j) - (L2 + L3 + a) \leq 40$ м.

Меры:

- Увеличьте диаметр трубопроводов L2 - L9 между первым и последним разветвителями, как показано в Таблице 3-4.2. Увеличение диаметра главных трубопроводов для внутренних блоков не требуется, поскольку диаметр данных трубопроводов совпадает с диаметром главного трубопровода L1.
- Требование 4:** Максимальный перепад высот между внутренним и наружным блоками не должен превышать 90 м, если наружный блок выше, и 110 м - если наружный блок ниже.
Примечание:
 - Если наружный блок располагается выше внутренних блоков и перепад высот превышает 20 м, рекомендуется установить масловозвратные петли в главном газовом трубопроводе с интервалом 10 м (см. Рисунок 3-4.1).
 - Если наружный блок располагается ниже внутренних блоков и перепад высот превышает 40 м, жидкостный главный трубопровод (L1) необходимо увеличить на один типоразмер (см. Таблицу 3-4.2).
 - Требование 5:** Максимальный перепад высот между внутренними блоками не должен превышать 30 м.

Таблица 3-4.2: Увеличение диаметров трубопроводов

Исходный диаметр трубопровода (мм)	Увеличенный диаметр трубопровода (мм)
Φ9,53	Φ12,7
Φ12,7	Φ15,9
Φ15,9	Φ19,1
Φ19,1	Φ22,2
Φ22,2	Φ25,4
Φ25,4	Φ28,6
Φ28,6	Φ31,8
Φ31,8	Φ38,1
Φ38,1	Φ41,3
Φ41,3	Φ44,5
Φ44,5	Φ54,0

Рисунок 3-4.1: Масловозвратные петли (Единица измерения: мм)

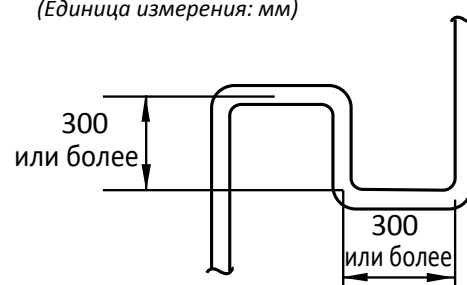

MVS FDC II-S

Рисунок 3-4.2: Допустимые значения длин трубопроводов хладагента и перепада высот между блоками

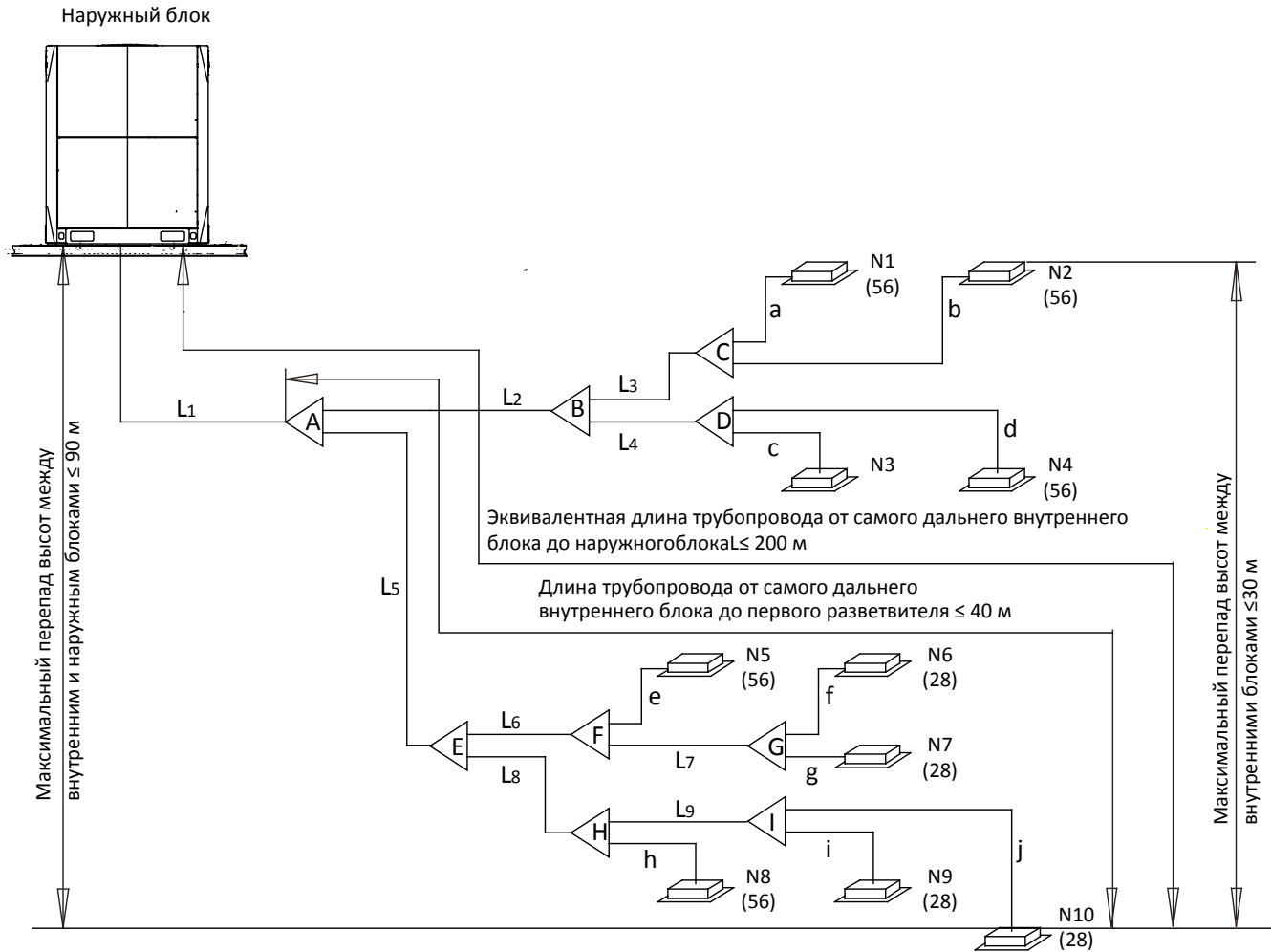

Обозначение		
L ₁	Главный трубопровод	Цифры в скобках обозначают показатели производительности внутренних блоков.
L ₂ to L ₉	Главные трубопроводы для внутренних блоков	
a to j	Дополнительные трубопроводы для внутренних блоков	
A to I	Разветвители внутренних блоков	

Таблица 3-4.3: Допустимые значения длин трубопроводов хладагента и перепада высот между блоками

		Допустимое значение	Трубопроводы, см. Рисунок 3-4.2	
Длина трубопровода	Общая длина трубопровода ¹	≤ 1000 м	$L_1 + 2 \times \sum\{L_2 \text{ to } L_9\} + \sum\{a \text{ to } j\}$	
	Длина трубопровода от наружного блока до самого дальнего внутреннего блока	Фактическая длина	≤ 175 м	$L_1 + L_5 + L_8 + L_9 + j$
		Эквивалентная длина	≤ 200 м	
	Длина трубопровода от первого разветвителя до самого дальнего внутреннего блока ³	≤ 40 м / 90 м	$L_5 + L_8 + L_9 + j$	
Перепад высот	Максимальный перепад высот между внутренним и наружным блоками ⁴	Наружный блок выше	≤ 90 м	
		Наружный блок ниже	≤ 110 м	
	Максимальный перепад высот между внутренними блоками ⁵	≤ 30 м		

Примечания:

1. См. Требование 1 выше.
2. См. Требование 2 выше.
3. См. Требование 3 выше.
4. См. Требование 4 выше.
5. См. Требование 5 выше.

4.4 Подбор диаметра трубопроводов

В Таблицах 3-4.4–3.4.8 ниже указаны необходимые диаметры трубопроводов для внутреннего и наружного блоков. Подберите главный трубопровод (L_1) и разветвитель (A), ориентируясь на Таблицы 3-4.4 и 3-4.5: выбирайте трубопровод с большим диаметром как главный трубопровод L_1 .

Рисунок 3-4.3: Подбор диаметра трубопроводов

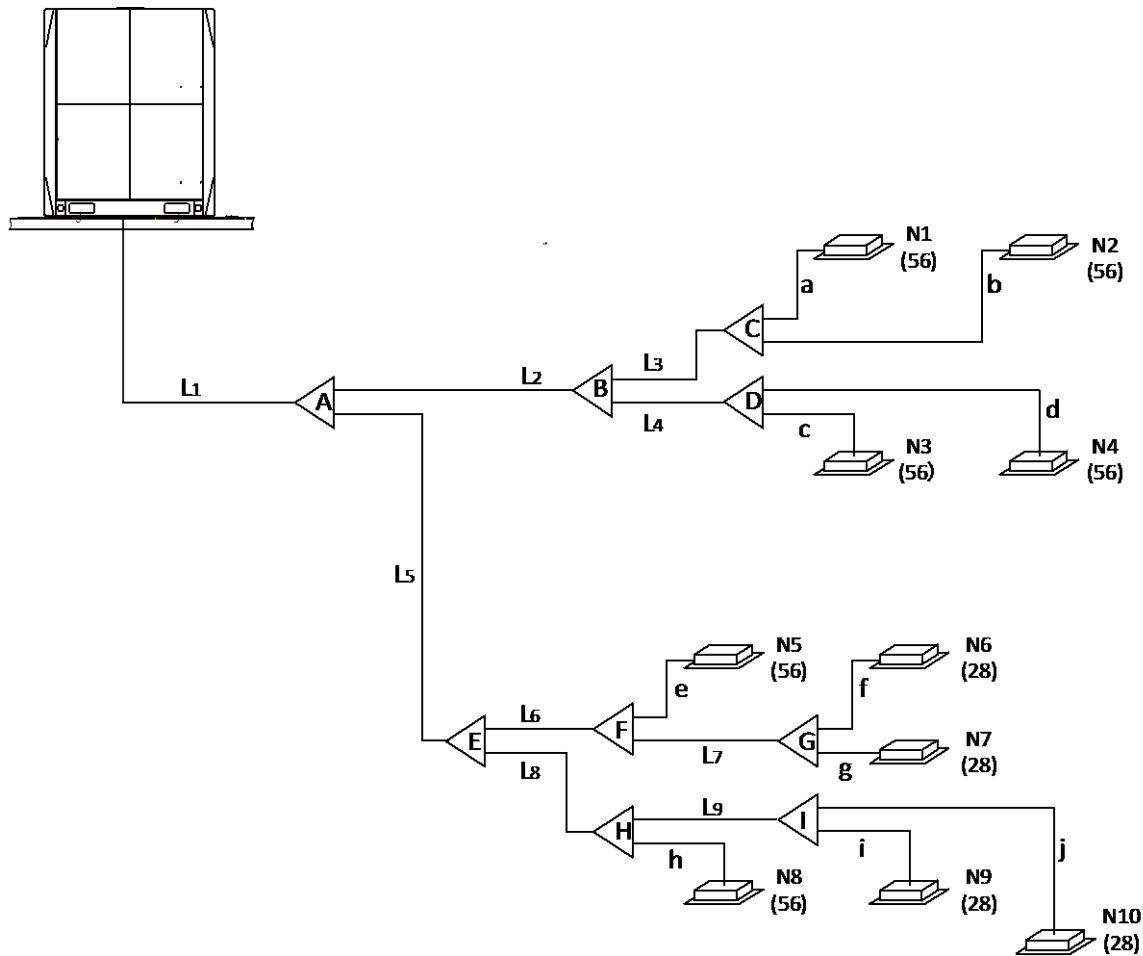

Обозначение		
L_1	Главный трубопровод	Цифры в скобках обозначают показатели производительности внутренних блоков.
L_2 to L_9	Главные трубопроводы для внутренних блоков	
a to j	Дополнительные трубопроводы для внутренних блоков	
A to I	Разветвители внутренних блоков	

Таблица 3-4.4: Главный трубопровод¹ (L), трубопроводы для внутренних блоков ($L - L$) и разветвители

Показатель полной производительности внутренних блоков	Газовый трубопровод (мм)	Жидкостный трубопровод (мм)	Разветвители
Показатели производительности < 168	Φ15,9	Φ9,53	MD-ZHN01E
168 ≤ Показатели производительности < 224	Φ19,1	Φ9,53	MD-ZHN01E
224 ≤ Показатели производительности < 330	Φ22,2	Φ9,53	MD-ZHN02E
330 ≤ Показатели производительности < 470	Φ28,6	Φ12,7	MD-ZHN03E
470 ≤ Показатели производительности < 710	Φ28,6	Φ15,9	MD-ZHN03E
710 ≤ Показатели производительности < 1040	Φ31,8	Φ19,1	MD-ZHN03E
1040 ≤ Показатели производительности < 1540	Φ38,1	Φ19,1	MD-ZHN04E

Примечания:

1. Подберите главный трубопровод (L_1) и разветвитель (A), ориентируясь на Таблицы 3-4.4 и 3-4.5: выбирайте трубопровод с большим диаметром как главный трубопровод L_1 .

Таблица 3-4.5: Главный трубопровод¹ (L) и разветвитель (A)

Производительность наружного блока	Эквивалентная длина всех жидкостных трубопроводов < 90 м			Эквивалентная длина всех жидкостных трубопроводов ≥ 90 м		
	Газовый трубопровод (мм)	Жидкостный трубопровод (мм)	Разветвители	Газовый трубопровод (мм)	Жидкостный трубопровод (мм)	Разветвители
18-24 л.с.	Φ28,6	Φ15,9	MD-ZHN03E	Φ31,8	Φ19,1	MD-ZHN03E
26-32 л.с.	Φ31,8	Φ19,1	MD-ZHN03E	Φ38,1	Φ22,2	MD-ZHN04E

Примечания:

1. Подберите главный трубопровод (L₁) и разветвитель (A), ориентируясь на Таблицы 3-4.4 и 3-4.5: выбирайте трубопровод с большим диаметром как главный трубопровод L₁.

Таблица 3-4.6: Дополнительные трубопроводы для внутренних блоков (a - j)

Производительность внутреннего блока (кВт)	Длина трубопровода ≤ 10 м		Длина трубопровода > 10 м ¹	
	Газовый трубопровод (мм)	Жидкостный трубопровод (мм)	Газовый трубопровод (мм)	Жидкостный трубопровод (мм)
≤ 4,5	Φ12,7	Φ6,35	Φ15,9	Φ9,53
≥ 5,6	Φ15,9	Φ9,53	Φ19,1	Φ12,7

Примечания:

1. Дополнительные трубопроводы для внутренних блоков (от внутреннего блока до ближайшего разветвителя) не должны иметь больший диаметр по сравнению с главными трубопроводами для внутренних блоков. Если длина дополнительных трубопроводов для внутренних блоков производительностью более или равной 5,6 кВт превышает 10 м, газовый и жидкостный трубопроводы необходимо увеличить на один типоразмер согласно данной таблице или подобрать диаметр, идентичный диаметру главного трубопровода, непосредственно идущего от внутреннего блока. В итоге выбирайте трубопроводы с меньшим диаметром.

4.5 Подбор трубопроводов хладагента

Ниже приведён образец подбора трубопроводов хладагента для системы, состоящей из одного наружного блока производительностью 16 л.с. и десяти внутренних блоков. Эквивалентная длина всех трубопроводов в данной системе превышает 90 м, длина трубопровода от первого разветвителя до самого дальнего внутреннего блока меньше 40 м, а трубопровод от внутреннего блока до ближайшего разветвителя меньше 10 м.

Рисунок 3-4.4: Образец подбора трубопроводов хладагента

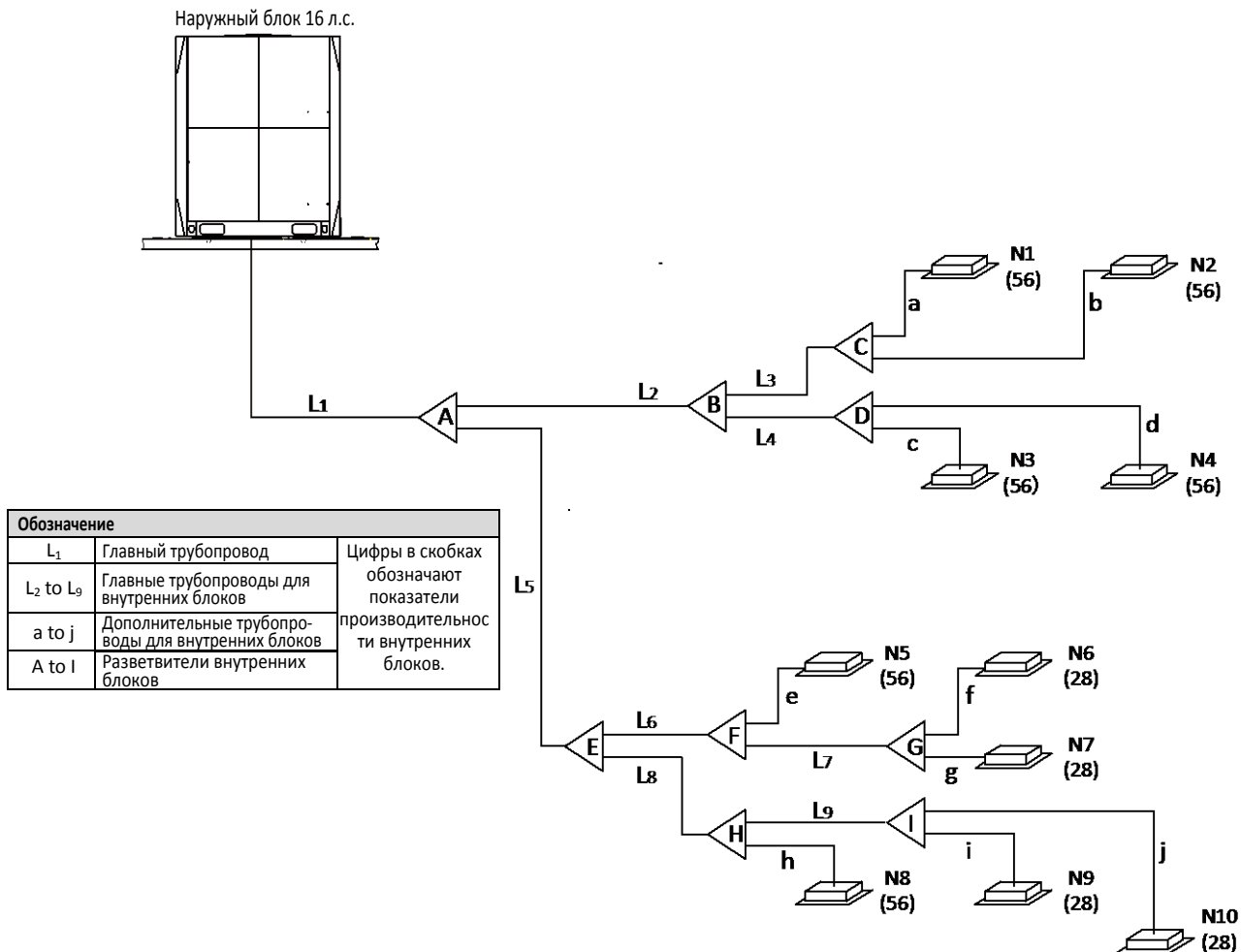

Этап 1: Подберите дополнительные трубопроводы для внутренних блоков

- N₁ - N₅ и N₈ - внутренние блоки производительностью 5,6 кВт, длина их дополнительных трубопроводов составляет 10 м. См. Таблицу 3-4.6. Диаметры дополнительных трубопроводов для внутренних блоков а – е и h - Ф15,9 / Ф9,53.
- N₆, N₇, N₉ и N₁₀ - внутренние блоки производительностью менее 4,5 кВт, длина их дополнительных трубопроводов составляет менее 10 м. См. Таблицу 3-4.6. Диаметры дополнительных трубопроводов для внутренних блоков f, g, i и j - Ф12,7 / Ф6,35.

Этап 2: Подберите главные трубопроводы и разветвители для внутренних блоков В - I

- N₁ и N₂ - идущие от разветвителя С внутренние блоки с полной производительностью 5,6 + 5,6 = 11,2 кВт. См. Таблицу 3-4.4. Диаметр главного трубопровода внутреннего блока L₃ - Ф15,9 / Ф9,53. Разветвитель для внутренних блоков С - MD-ZHN01E.
- N₁ - N₄ - идущие от разветвителя В внутренние блоки с полной производительностью 5,6 x 4 = 22,4 кВт. См. Таблицу 3-4.4. Диаметр главного трубопровода внутреннего блока L₂ - Ф19,1 / Ф9,53. Разветвитель для внутренних блоков В - 2.
- Подберите остальные главные трубопроводы и разветвители для внутренних блоков аналогичным способом.

Этап 3: Подберите главный трубопровод и разветвитель для внутренних блоков А

- N₁ - N₁₀ - идущие от разветвителя А внутренние блоки с полной производительностью 5,6 x 6 + 2,8 x 4 = 44,8 кВт. Эквивалентная длина всех жидкостных трубопроводов в системе превышает 90 м. Производительность наружного блока 16 л.с. См. Таблицы 3-4.4 и 3-4.5. Диаметр главного трубопровода L₁ - Ф28,6 / Ф12,7 и Ф31,8 / Ф15,9. В итоге выбирайте трубопровод с большим диаметром Ф31,8 / Ф15,9 как главный трубопровод L₁. Разветвитель для внутренних блоков А - MD-ZHN03E.

4.6 Разветвители

При проектировании учитывайте следующее:

- Используйте только U-образные разветвители, тройники запрещены. Размеры разветвителей указаны в Таблице 3-4.7.
- Для обеспечения равномерного распределения хладагента категорически запрещены повороты трубопроводов с острыми углами (менее 90°) и подключение разветвителей на расстоянии менее 500 мм. Минимальное расстояние между соседними разветвителями также должно составлять не менее 500 м, как показано на Рисунке 3-4.5.

Рисунок 3-4.5: Расположение разветвителей и расстояние между поворотами (Единица измерения: мм)



Таблица 3-4.7: Размеры разветвителей для внутренних блоков (Единица измерения: мм)

Модель	Разветвители газовых трубопроводов	Разветвители жидкостных трубопроводов
MD-ZHN01E		
MD-ZHN02E		
MD-ZHN03E		
MD-ZHN04E		

4.7 Меры технической безопасности в случае обнаружения утечки хладагента

Данная система кондиционирования работает на основе хладагента R410A, который является экологически безопасным и непожароопасным при атмосферном давлении и температуре не выше +100°C. Тем не менее следует принять меры предосторожности, чтобы избежать маловероятной, но возможной опасности для жизни в случае утечки хладагента. Меры предосторожности должны быть приняты в соответствии со всеми нормами действующего законодательства. Если такие меры не предусмотрены действующим законодательством, то в качестве руководства можно использовать следующее:

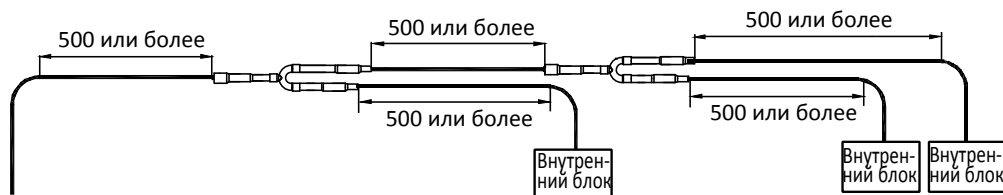
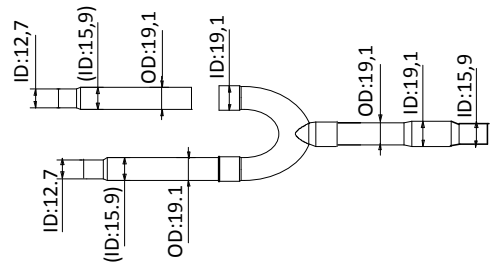
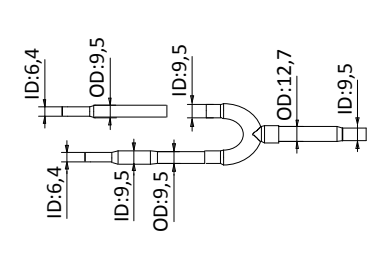
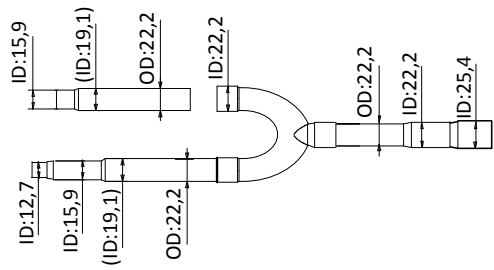
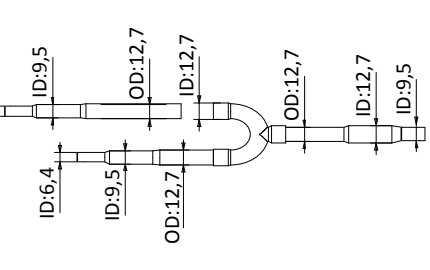
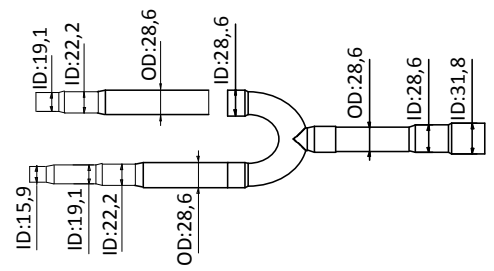
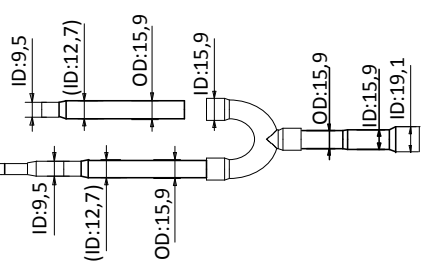
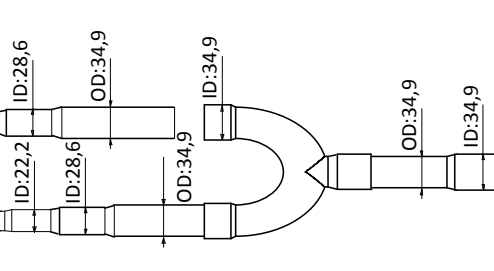
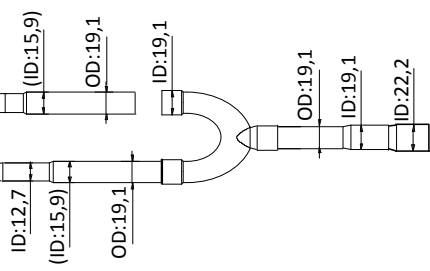
Кондиционируемые помещения должны иметь достаточно большой объем и площадь для того, чтобы концентрация не достигла критических показателей в случае возникновения утечки хладагента, а также для обеспечения достаточного времени для принятия соответствующих мер по устранению неисправности.

Предельно допустимая концентрация хладагента R410A: 0,3 кг/м³, (предельно допустимая концентрация: максимальная концентрация фреона, безопасная для здоровья человека).

Рассчитайте предельно допустимую концентрацию хладагента согласно следующим пунктам и примите соответствующие меры безопасности:

- Рассчитайте суммарный вес заправленного в систему хладагента А (вес хладагента, заправленного на заводе-производителе, указанный в паспортных данных оборудования, и дополнительное количество хладагента, заправленного в систему). См. Часть 3, п. 8. данного руководства «Заправка дополнительного количества хладагента».
- Рассчитайте объем самого малого по площади помещения (В), где возможна утечка хладагента.
- Рассчитайте предельно допустимую концентрацию хладагента А/В.
- Если А/В составляет более 0.3 кг/м³, примите защитные меры по удалению избыточного количества хладагента. Например, установите механическую вентиляцию для снижения концентрации хладагента: регулярно проветривайте помещение или установите вентиляцию, управляемую детектором утечки хладагента.

Поскольку R410A тяжелее воздуха, особое внимание следует уделить случаям возможных утечек в подвальных помещениях.

Рисунок 3-4.6: Пример возможной утечки хладагента



Рисунок 3-4.7: Механическая вентиляция, управляемая детектором утечки хладагента



5. Монтаж трубопровода хладагента

5.1 Порядок выполнения работ и основные требования

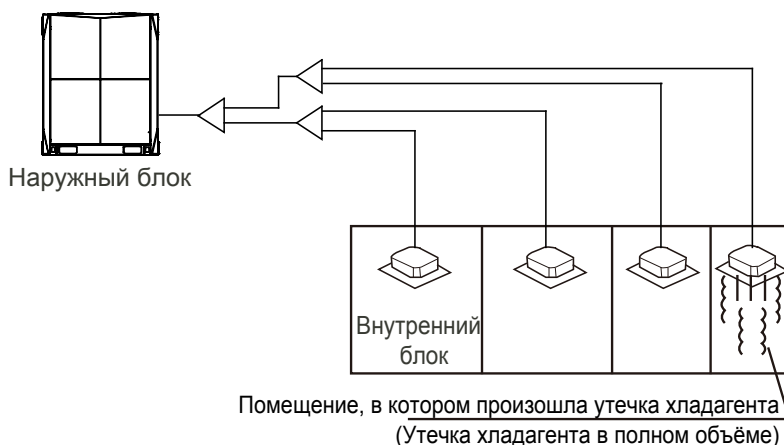
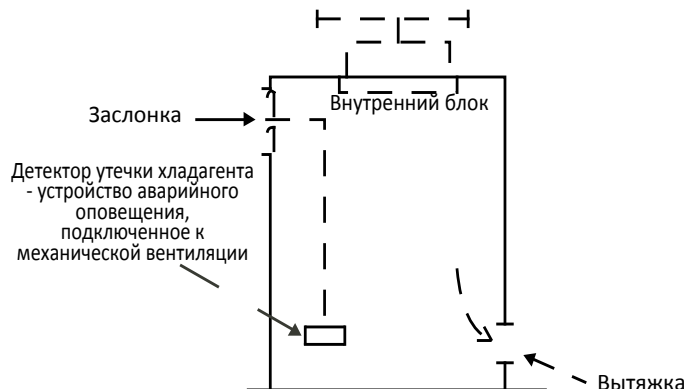
5.1.1 Порядок выполнения работ

Примечания для специалистов по монтажу

Монтаж трубопровода хладагента должен осуществляться в следующем порядке:

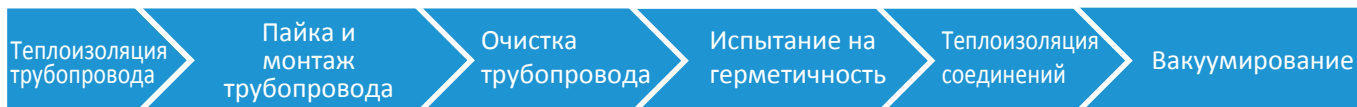

Примечание: Очистка трубопровода должна выполняться после завершения процесса пайки трубопровода, за исключением окончательного подсоединения к внутренним блокам. То есть очистку трубопровода необходимо осуществлять после подключения наружного блока, но до подключения внутренних блоков.

5.1.2 Три правила монтажа трубопроводов хладагента

	Основание	Профилактические меры
Очистка	Окисление меди при пайке и/или попадание пыли внутрь труб могут привести к неисправностям компрессора	<ul style="list-style-type: none"> • Теплоизоляция трубопровода перед хранением¹ • Использование азота при пайке во избежание окисления² • Очистка трубопровода³
Осушение	Влага может привести к обмерзанию или окислению внутренних частей блока, что приведёт к поломке компрессора	<ul style="list-style-type: none"> • Очистка трубопровода³ • Вакуумирование⁴
Герметичность	Ошибки при герметизации могут привести к утечкам хладагента	<ul style="list-style-type: none"> • Соблюдение требований к развальцовке⁵ и пайке труб² • Испытание на герметичность⁶

Примечания:

1. См. Часть 3, п. 5.2.1 «Доставка, хранение и изоляция медных труб».
2. См. Часть 3, п. 5.5 «Пайка».
3. См. Часть 3, п. 5.7 «Очистка трубопровода».
4. См. Часть 3, п. 5.9 «Вакуумирование».
5. См. Часть 3, п. 5.3 «Обработка медных труб».
6. См. Часть 3, п. 5.8 «Испытание на герметичность».

5.2 Хранение медных труб

5.2.1 Доставка, хранение и изоляция медных труб

Примечания для специалистов по монтажу

- Избегайте изгибания или деформации трубы во время доставки или хранения.
- Храните трубы строго в отведенном месте на строительном объекте.
- Во избежание воздействия влаги и пыли трубы должны быть изолированы во время хранения или до подсоединения. Перед подсоединением изолируйте торцы медных труб, используя пробку или клейкую изоляционную ленту. Если трубопровод отложен на продолжительное хранение, заправьте его азотом при 0,2-0,5 МПа и изолируйте оба конца трубопровода путём пайки.
- Хранение труб на земле подвергает их воздействию влаги и пыли. Используйте деревянные поддоны для хранения медной трубы выше уровня земли, что, таким образом, защитит ее от воздействия влаги и пыли.
- Во время прокладки медной трубы через отверстие в стене различные загрязнения могут попасть внутрь трубы, поэтому концы медных труб необходимо изолировать.
- Если медная труба расположена с наружной стороны стены, убедитесь, что трубопровод защищен от попадания в него осадков, в особенности если он направлен вверх.

5.3 Обработка медных труб

5.3.1 Удаление масла из медных труб системы, работающей на основе хладагента R410A

Примечания для специалистов по монтажу

- Техническое масло, используемое во время обработки медных труб в процессе их производства, имеет состав смазочных материалов, отличающийся от состава смазочных материалов, предназначенных для систем, работающих на основе хладагента R410A. Состав таких смазочных материалов может оставлять осадок в системе, способный привести к серьезным ошибкам в работе системы. В связи с этим для системы, работающей на основе хладагента R410a, необходимо подбирать сухие трубы - без масла. При использовании стандартных медных труб в масле, необходимо произвести их прочистку с помощью марли, смоченной в растворе тетрахлорэтилена.

Осторожно

- Категорически запрещается использовать CCl₄ в целях прочистки труб во избежание серьезных повреждений системы.

5.3.2 Резка трубопровода и обработка торцевой кромки медной трубы

Примечания для специалистов по монтажу

- Используйте труборез вместо ножовки или металлорежущей отрезной машины. Аккуратно и медленно поворачивайте трубопровод, оказывая равномерное физическое воздействие на него. Отрежьте трубопровод, предварительно убедившись, что в процессе резки он не подвергается деформации. Во время использования ножовки или металлорежущей отрезной машины в трубопровод может попасть медная стружка, которую очень сложно устранить. Если медную стружку не удастся своевременно удалить из трубопровода, она может стать причиной серьезных неисправностей при попадании в компрессор или дросселирующее устройство.
- После резки трубопровода используйте риммер для устранения заусенцев с торцевой кромки медной трубы, при этом труба должна быть направлена отверстием вниз во избежание попадания медной стружки в трубопровод.
- Убедитесь, что трубы не покрыты царапинами, во избежание образования трещин при развальцовке, которые могут привести к повреждению изоляции и, как следствие, утечкам хладагента.

5.3.3 Расширение трубы для подсоединения другой медной трубы

Примечания для специалистов по монтажу

- Расширение трубы для подсоединения другой медной трубы служит в качестве альтернативы использованию муфты, что освобождает от необходимости пайки еще одного шва.
- Вставьте насадку труборасширителя в трубопровод. После завершения процесса расширения прокрутите медную трубу на несколько градусов для выравнивания внутренней поверхности.

Осторожно

- Убедитесь в равномерности и гладкости торцов обеих труб; после завершения процесса резки трубы удалите заусенцы.

Рисунок 3-5.1: Расширение трубы

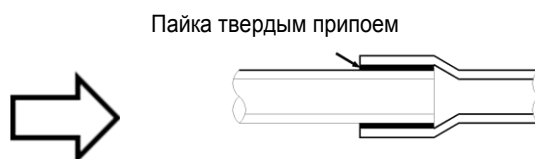
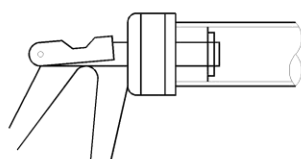

5.3.4 Подготовка конуса (развальцованной части трубопровода)

Конус предназначен для разъемных резьбовых соединений.

Примечания для специалистов по монтажу

- Перед подготовкой конуса полутвердой трубы (1/2Н) необходимо обжечь её края.
- Перед вальцеванием наденьте на трубу конусную гайку.
- Аккуратно удалите заусенцы во избежание трещин в области конуса, которые могут привести к утечке хладагента.
- Диаметры конусов указаны в Таблице 3-5.1. См. Рисунок 3-5.2.

Таблица 3-5.1: Диаметры конусов (развальцованной части трубопровода)

Диаметр трубы (мм)	Диаметр конуса (А) (мм)
Φ6,35	8,7 - 9,1
Φ9,53	12,8 - 13,2
Φ12,7	16,2 - 16,6
Φ15,9	19,3 - 19,7
Φ19,1	23,6 - 24,0

Рисунок 3-5.2: Конус

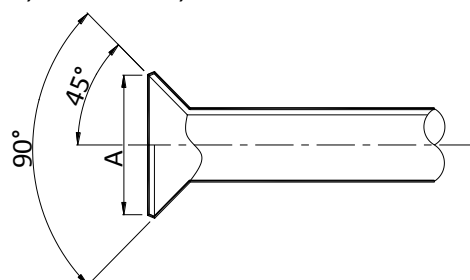

Добавьте некоторое количество холодильного масла на внутреннюю и наружную поверхность конуса для легкости соединения или прокручивания конусной гайки, обеспечьте надежное соединение между прилегающим резьбовым штуцером и конусом, избегайте поворотов трубы в полученном соединении.

5.3.5 Изгибание трубы

Изгибание медной трубы сокращает число паяных соединений при поворотах труб, в результате чего повышается техническое качество системы трубопроводов, экономятся расходные материалы, отсутствуют паяные швы.

Примечания для специалистов по монтажу

Методы изгибания трубы

- Изгибание вручную предназначено для медных труб небольшого диаметра (Ф6,35 мм - Ф12,7 мм).
- Механическое изгибание с использованием пружинного, ручного или электрического трубогиба предназначено для широкого спектра медных труб (Ф6,35 мм - Ф54,0 мм).

Осторожно

- При использовании пружинного трубогиба убедитесь, что он чистый, прежде чем вставлять его в медную трубу.
- При изгибании медной трубы убедитесь в отсутствии неровностей и деформации с обеих сторон трубопровода.
- Убедитесь, что угол изгиба не превышает 90°, в обратном случае на внутренней стороне трубопровода могут возникнуть неровности и трещины. См. Рисунок 3-5.3.
- Убедитесь в том, что труба не опускается во время процесса изгибания; убедитесь в том, что поперечное сечение изгибаемой трубы превышает 2/3 исходной площади, в обратном случае процесс изгибания невозможен.

Рисунок 3-5.3: Угол изгиба превышает 90°



5.4 Опоры для трубопровода хладагента

Во время эксплуатации системы кондиционирования трубопровод хладагента деформируется (например, он может сжиматься/расширяться либо прогибаться). Во избежание поломки трубопровода используйте шпильки и опоры (ознакомьтесь с требованиями в Таблице 3-5.2 ниже. В стандартных условиях газовый и жидкостный трубопроводы должны быть подвешены параллельно друг другу, при этом интервал между точками опоры должен быть подобран согласно диаметру газового трубопровода.

Таблица 3-5.2. Расстояние между опорами трубопроводов хладагента

Диаметр трубопровода (мм)	Расстояние между точками опоры (м)	
	Горизонтальный трубопровод	Вертикальный трубопровод
< Ф20	1	1,5
Ф20 – Ф40	1,5	2
> Ф40	2	2,5

Используйте подходящую теплоизоляцию между трубопроводом и опорами. При использовании деревянных дюбелей убедитесь, что они имеют антикоррозийное покрытие.

Температура хладагента может изменяться по мере работы системы согласно условиям эксплуатации, что приводит к расширению или сжатию трубопровода хладагента, поэтому не следует оказывать чрезмерное давление на трубопровод с теплоизоляционным слоем во избежание повреждений медных труб в результате избыточного механического воздействия.

5.5 Пайка

Избегайте образования окалины на внутренней стенке медной трубы во время пайки. Если во время пайки в систему поступает недостаточное количество азота, на внутренней стенке медной трубы может образоваться окалина, которая, в свою очередь, уменьшает расход хладагента, в результате чего возможны такие неисправности, как сгорание компрессора, низкая холодопроизводительность. Во избежание данных неисправностей медленно подавайте азот в трубопроводы хладагента во время пайки.

Примечания для специалистов по монтажу

Предупреждение

- Убедитесь, что во время пайки используется именно азот. Категорически запрещается использовать кислород! В противном случае на внутренней стенке медной трубы может образоваться окалина, которая, в свою очередь, может стать причиной возгорания или взрыва.
- Примите противопожарные меры технической безопасности во время пайки (убедитесь, что рабочая зона оснащена огнетушителем).

Подача азота для защиты медной трубы во время пайки

- Используйте редуктор и поддерживайте давление азота на уровне около 0,02-0,03 МПа во время пайки.
- Медленно подавайте азот в трубопроводы хладагента до начала пайки. Убедитесь, что азот непрерывно поступает до завершения процесса сварки и полного остывания медной трубы.

Рисунок 3-5.4: Подача азота для защиты медной трубы во время пайки

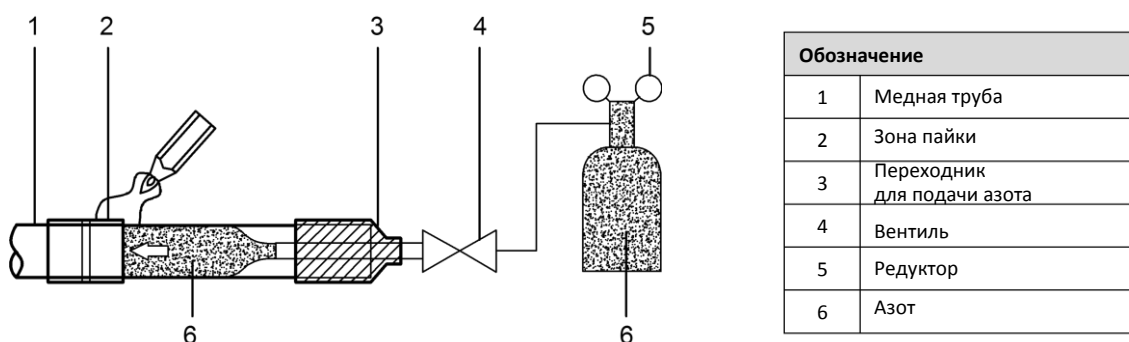

- При подсоединении короткой трубы к длинной подавайте азот со стороны короткой трубы, так как небольшое расстояние позволит более эффективно вытеснить кислород.
- Если трубопровод между точкой подачи азота и зоной пайки слишком длинный, убедитесь, что подача азота осуществляется на протяжении всего промежутка времени, необходимого для полного удаления воздуха из трубопровода.

Рисунок 3-5.5: Подача азота со стороны короткой трубы во время пайки

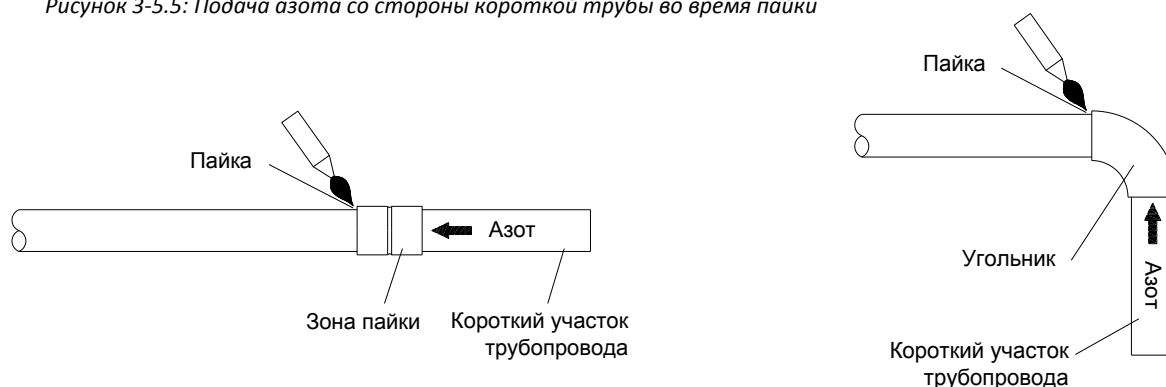

продолжение на следующей странице...

... продолжение с предыдущей страницы

Положение трубы во время пайки

Старайтесь паять раструб сверху вниз или в горизонтальном положении, избегайте пайки раструба снизу вверх.

Рисунок 3-5.6: Положение трубы во время пайки

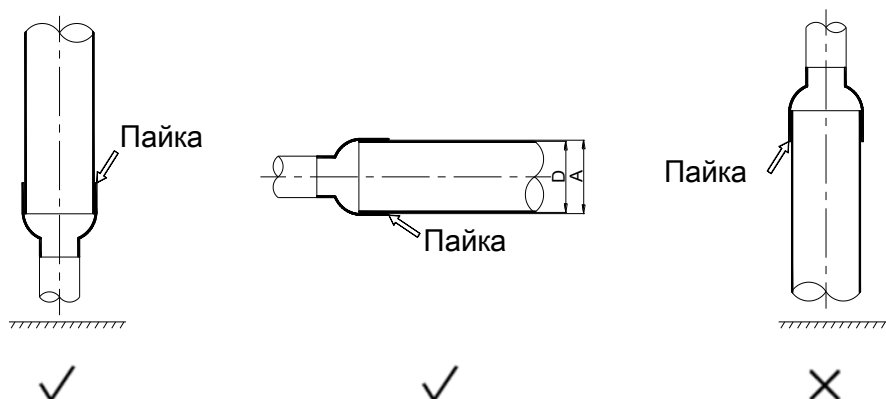

Соотношение между минимальной глубиной вставки и зазором в соединении медных труб

Следующая Таблица 3-5.3 показывает соотношение между минимальной глубиной вставки и зазором в соединении медных труб. Также см. Рисунок 3-5.7.

Рисунок 3-5.7: Соотношение между минимальной глубиной вставки и зазором в соединении медных труб

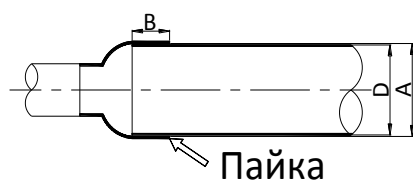

Обозначение	
A	Внутренний диаметр трубы большего диаметра
D	Наружный диаметр трубы меньшего диаметра
B	Глубина вставки

Таблица 3-5.3: Соотношение между минимальной глубиной вставки и зазором в соединении медных труб¹

Наружный диаметр трубопровода D (мм)	Минимальная глубина вставки B (мм)	Зазор A-D (мм)
5 < D < 8	6	0,05 - 0,21
8 < D < 12	7	
12 < D < 16	8	0,05 - 0,27
16 < D < 25	10	
25 < D < 35	12	0,05 - 0,35
35 < D < 45	14	

Примечания:

1. A, B, относятся к габаритным размерам, показанным на Рисунке 3-5.7.

Припой

- Используйте только твердый меднофосфорный (BCuP) припой без флюса.
- Припой с флюсом оказывает крайне неблагоприятное воздействие на трубопровод. Например, использование флюса на основе хлора вызывает коррозию трубопровода, в то время как использование флюса на основе фтора разрушает смазочные свойства холодильного масла.
- Во время пайки соединений трубопровода не используйте антиоксиданты. Иначе на стенках трубопровода может появиться осадок, что приведет к повреждению агрегата.

5.6 Разветвители

Примечания для специалистов по монтажу

- Используйте U-образные разветвители, указанные в инструкциях. Используйте только U-образные разветвители, тройники запрещены.
- Разветвители для внутренних блоков могут быть установлены горизонтально или вертикально. Горизонтальные разветвители должны быть установлены горизонтально под углом не более 10° . Иначе распределение хладагента будет неравномерным, в результате чего может возникнуть неисправность. См. Рисунок 3-5.8.
- Для обеспечения равномерного распределения хладагента и во избежание накопления масла в наружном блоке, пожалуйста, устанавливайте разветвители в правильном положении с учётом ограничений по отношению к изгибам, другим разветвителям и прямым участкам трубопровода, подключаемым к внутренним блокам. См. Часть 3, п. 4.6 «Разветвители».

Рисунок 3-5.8: Положение разветвителя

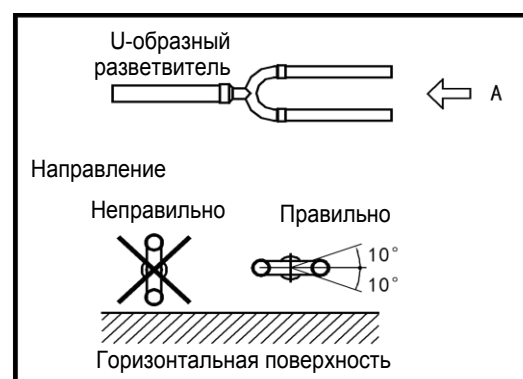

5.7 Очистка трубопровода

5.7.1 Цель

Устранение загрязнений, твердых частиц и влаги из трубопровода, которые могут привести к серьезным неисправностям компрессора при отсутствии принятия соответствующих мер. Очистка трубопровода хладагента должна осуществляться с использованием азота. Как описано в Части 3, п. 5.1.1 «Порядок выполнения работ», очистка трубопровода должна выполняться после завершения процесса пайки трубопровода, за исключением окончательного подсоединения к внутренним блокам. То есть очистку трубопровода необходимо осуществлять после подключения наружного блока, но до подключения внутренних блоков.

Примечания для специалистов по монтажу **Предупреждение**

Для продувки используйте только азот. Использование политетрафторэтилена или диоксида углерода может привести к конденсации. Использование кислорода может привести к взрыву, поэтому его применение категорически запрещено.

Порядок выполнения работ

Очистку жидкостного и газового трубопроводов можно осуществлять одновременно или по отдельности: для этого выполните шаги 1-8 ниже для одного из трубопроводов, после чего повторно выполните данные шаги – для другого. Процесс очистки трубопроводов описан ниже:

1. Перекройте входы и выходы внутренних блоков во избежание попадания в них загрязнений в процессе продувки. (Очистку трубопровода необходимо осуществлять до подключения внутренних блоков).
2. Установите редуктор давления на баллоне с газообразным азотом.
3. Подключите редуктор давления ко входу жидкостного (или газового) трубопровода наружного блока.
4. Используйте заглушки для полного перекрытия портов жидкостной (газовой) линии всех блоков, исключая внутренний блок, самый дальний от наружного блока (внутренний блок А на Рисунке 3-5.9).
5. Откройте вентиль баллона с газообразным азотом, постепенно увеличивая давление до 0,5 МПа.
6. Убедитесь, что азот поступил в систему через жидкостный трубопровод внутреннего блока А.
7. Продувка первого входа:
 - a) Используйте соответствующий материал, например, пакет или ткань, и прижмите его к резьбовому порту газовой трубы внутреннего блока А.
 - b) По мере повышения давления, как только станет трудно удерживать шланг рукой, отпустите материал, чтобы выпустить газ для продувки.
 - c) Пройдите вышеуказанные пункты для повторной (многократной) продувки трубы до тех пор, пока загрязнения и влага не будут полностью удалены из трубопроводов. Во время продувки поместите кусочек белой ткани на выходе трубопровода для проверки наличия влаги. После завершения процесса продувки изолируйте вход трубопровода во избежание попадания в него влаги или загрязнений.
8. Повторите все вышеописанные процедуры при подключении медных труб ко всем остальным внутренним блокам в следующей последовательности: от внутреннего блока А к следующему блоку по направлению к наружному блоку. См. Рисунок 3-5.10.
9. После завершения процесса продувки изолируйте все входы трубопроводов во избежание попадания в них влаги или загрязнений.

Рисунок 3-5.9: Очистка трубопровода с использованием азота

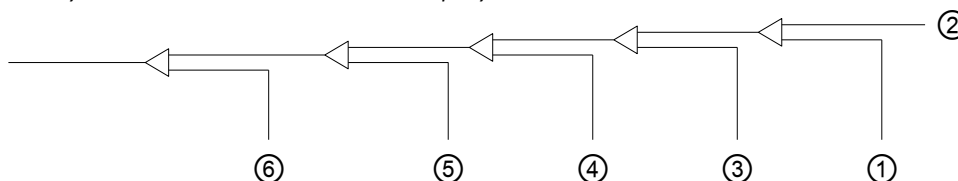

Рисунок 3-5.10: Последовательность продувки¹

**Примечания:**

1. Продувка осуществляется от самого дальнего к ближайшему блоку относительно наружного блока в следующей последовательности: 1-2-3-4-5-6.

5.8 Испытание на герметичность

5.8.1 Цель

Испытание на герметичность необходимо проводить до ввода в эксплуатацию для предотвращения неисправностей в работе системы кондиционирования в результате утечек хладагента.

5.8.2 Проведение испытания на герметичность

Примечания для специалистов по монтажу

Предупреждение

Во время проведения испытания используйте только сухой азот марки N. Кислород, легковоспламеняющийся или токсичный газ категорически запрещены для использования во время проведения испытания на герметичность. Использование кислорода или токсичных газов может стать причиной возгорания или взрыва.

Порядок выполнения работ

Процесс проведения испытания на герметичность описан ниже:

Этап 1

- После завершения монтажа трубопроводов и подключения к внутренним и наружным блокам вакуумируйте систему под давлением -0,1 МПа.

Этап 2

- Заправьте трубопровод внутренних блоков азотом под давлением 0,3 МПа через игольчатые клапаны и поддерживайте давление на данном уровне не менее 3 минут (жидкостный и газовый вентили при этом должны быть закрыты). Проверьте наличие больших утечек в системе с помощью манометра. Значительное падение давления свидетельствует о наличии большой утечки в системе.
- При отсутствии больших утечек заправьте трубопровод азотом под давлением 1,5 МПа и поддерживайте давление на данном уровне не менее 3 минут. Проверьте наличие небольших утечек в системе с помощью манометра. Незначительное, но заметное падение давления свидетельствует о наличии небольшой утечки в системе.
- При обнаружении небольших утечек заправьте трубопровод азотом под давлением 4 МПа. Давление в системе должно поддерживаться в течение 24 часов для проверки на наличие утечек. Обнаружить микроутечки достаточно сложно. Для обнаружения микроутечек в системе проверьте, изменяется ли давление в соответствии с изменением температуры в течение всего испытания. При разнице температур в помещении 1 °С разница давлений будет составлять 0,01 МПа. Расчетное давление = Избыточное давление в начале опрессовки + (разница температур в начале и в конце опрессовки) x 0,01 МПа. Сравните полученное значение со значением давления в конце опрессовки. Если значения совпадают, это указывает на отсутствие утечек. Если значение давления в конце опрессовки ниже расчетного значения давления, это указывает на наличие микроутечек в трубопроводе.
- При обнаружении утечки см. Часть 3, п. 5.8.3 «Поиск места утечки». Как только утечка найдена и устранена, испытание на герметичность необходимо провести повторно.

Этап 3

- Если Вы не планируете приступить к процессу вакуумирования сразу после проведения испытания на герметичность (см. Часть 3, п. 5.9 «Вакуумирование»), понизьте давление в системе до 0,5-0,8 МПа и поддерживайте его на данном уровне до готовности к выполнению процесса вакуумирования.

Рисунок 3-5.11: Испытание на герметичность

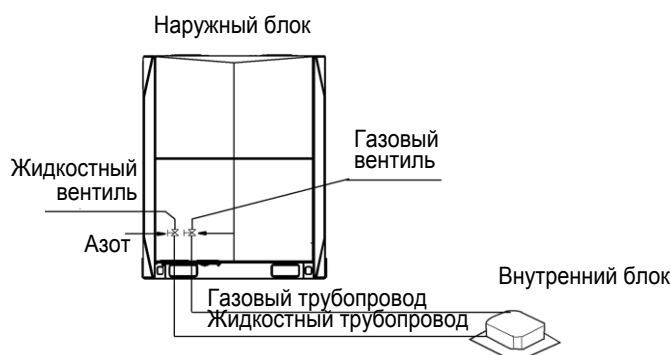

Примечания для специалистов по монтажу

Основные методы поиска места утечки перечислены ниже:

1. Определение больших утечек по шуму.
2. Определение места утечки касанием: приложите руку предполагаемому источнику для тактильного определения наличия утечки.
3. Использование мыльного раствора предназначено для определения небольших утечек. Выходящий газ будет создавать пузырьки в месте утечки после применения мыльного раствора.
4. Определение источника утечки с помощью электронного течеискателя: Используйте электронный течеискатель в случае затруднений в определении источника утечки стандартными методами.
 - a) Поддерживайте избыточное давление азота на уровне 0,3 МПа.
 - b) Добавьте хладагент R410a до уровня 0,5 МПа.
 - c) Используйте электронный течеискатель для определения источника утечки.
 - d) Если источник утечки определить не удастся, продолжайте опрессовку избыточным давлением на уровне 4 МПа, после чего повторите попытку.

5.9 Вакуумирование

5.9.1 Цель

Вакуумирование предназначено для удаления влаги и неконденсируемых газов из системы. Удаление влаги из контура препятствует обмерзанию и окислению медных труб и внутренних компонентов системы. Обмерзание приведет к снижению производительности, а омеднение может повредить компрессор. Неконденсируемые газы в системе приведут к колебаниям давления в системе и низкой производительности.

Вакуумирование также предназначено для определения утечки (в дополнение к испытанию на герметичность).

5.9.2 Процесс вакуумирования

Примечания для специалистов по монтажу 

В процессе вакуумирования вакуумный насос снижает давление в системе и, таким образом, переводит небольшое количество влаги, содержащейся в контуре, из жидкого в газообразное состояние. При 5 мм рт.ст. (что на 755 мм рт.ст. ниже атмосферного давления) точка кипения воды составляет 0 °С. Давление всасывания вакуумного насоса должно составлять не менее 756 мм рт.ст. Используйте вакуумный насос производительностью 4 л/сек и с разрежением до 0,02 мм рт.ст.

Осторожно:

- Во время проведения испытания на герметичность убедитесь, что газовый и жидкостный вентили полностью перекрыты во избежание попадания азота в наружный блок.
- В процессе вакуумирования системы на основе хладагента R410A вакуумный насос может отключиться. В результате процесса всасывания масло из вакуумного насоса попадает в холодильный контур. Как следствие, может произойти смешение различных масел, что приведет к неисправностям в работе системы, поэтому рекомендуется использовать обратный клапан во избежание перетока масла из насоса в систему.

Порядок выполнения работ

Процесс осушения контура с помощью вакуумирования описан ниже

Этап 1

- Подсоедините синий шланг (сторона низкого давления) манометра к газовому вентилю наружного блока, красный шланг (сторона высокого давления) к жидкостному вентилю наружного блока и желтый шланг - к вакуумному насосу.

Этап 2

- Включите вакуумный насос, а затем откройте клапаны манометра, чтобы начать процесс вакуумирования системы.
- Через 30 минут закройте клапаны манометра.
- Еще через 5-10 минут проверьте манометр. При падении давления до 0 проверьте трубопровод хладагента на наличие утечек.

Этап 3

- Снова откройте клапаны манометра и продолжайте процесс вакуумирования в течение не менее 2 часов, пока разница давлений не составит 756 мм рт.ст. или более. Когда разница давлений составит не менее 756 мм рт.ст., продолжите процесс вакуумирования ещё в течение 2 часов.

Этап 4

- Закройте клапаны манометра и затем выключите вакуумный насос.
- Через 1 час проверьте манометр. Если давление в трубопроводе не повысилось, завершите процесс вакуумирования. Если давление в трубопроводе повысилось, проверьте контур на наличие утечек.
- После завершения процесса вакуумирования оставьте синий и красный шланги подключёнными к манометру и газовому и жидкостному вентилям наружного блока и, таким образом, готовыми для заправки хладагента (См. Часть 3, п. 8 «Заправка дополнительного количества хладагента»).

Рисунок 3-5.12: Вакуумирование

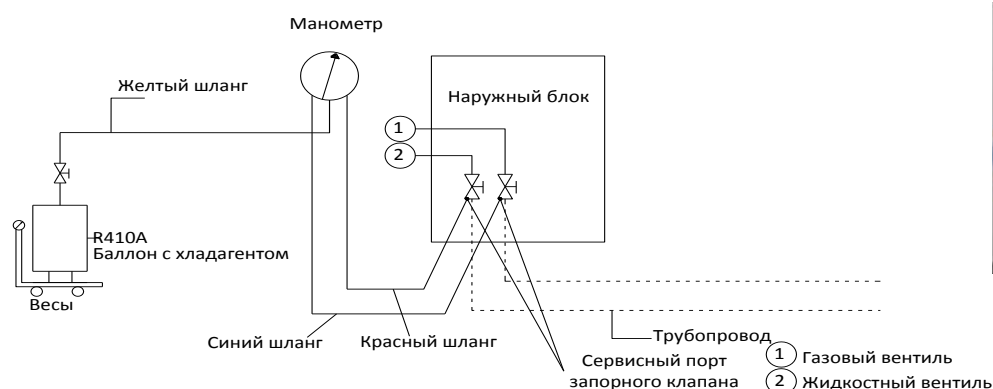

Манометр

6. Монтаж дренажных трубопроводов

6.1 Проектирование дренажных трубопроводов

При проектировании дренажных трубопроводов обратите особое внимание на следующие пункты:

- Для обеспечения слива конденсата из дренажа, который образуется внутренними блоками в процессе эксплуатации, прокладывайте дренажный трубопровод необходимого диаметра от внутреннего блока под уклоном. Участки дренажных трубопроводов должны быть короткими, а дренажные выходы должны располагаться как можно ближе к внутреннему блоку.
- Во избежание провисания дренажного трубопровода в результате чрезмерно большой длины рекомендуется установить систему из нескольких дренажных трубопроводов, каждый из которых оснащён своим дренажным выходом. Если используется дренажный трубопровод большой длины, установите подвесные опоры для обеспечения необходимого угла уклона (1/100) во избежание провисания трубопровода. См. Рисунок 3-6.1.
- Перед монтажом дренажного трубопровода определите направление трассы и подъема во избежание пересечения с другими трубопроводами и преградами, такими как балки и система вентиляции, а также для обеспечения надежного слива конденсата под уклоном.

Рисунок 3-6.1: Минимальный уклон дренажного трубопровода должен составлять не менее 1/100

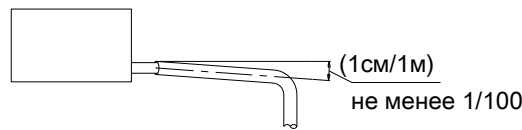

- Убедитесь, что два горизонтальных дренажных трубопровода не соединяются в одной плоскости, во избежание обратного потока и других неисправностей. Схему правильного подключения см. на Рисунке 3-6.2. Благодаря такой схеме подключения, угол уклона двух дренажных трубопроводов можно установить по отдельности.

Рисунок 3-6.2: Схема правильного и неправильного подключений дренажных трубопроводов

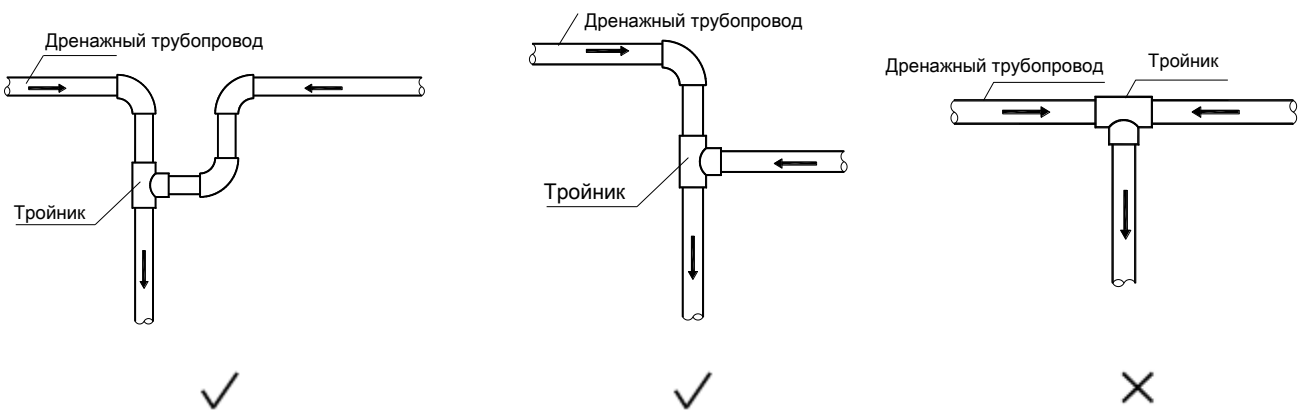

- Соединительные трубопроводы должны подключаться к общему дренажному трубопроводу сверху, как показано на Рисунке 3-6.3.
- Расстояние между подвесными опорами должно составлять 0,8 – 1,0 м для горизонтального трубопровода и 1,5 – 2,0 м для вертикального трубопровода. Каждый вертикальный трубопровод должен быть оснащён по крайней мере двумя подвесными опорами. Слишком большое расстояние между подвесными опорами может привести к провисанию трубопровода, что может стать причиной образования воздушных пробок.
- Для обеспечения равномерного и беспрепятственного слива конденсата наивысшая точка дренажного трубопровода должна быть оснащена U-образным поворотом или угольником для отвода воздуха. При этом угольник должен быть развернут вниз во избежание попадания пыли и загрязнений в трубопровод. См. Рисунок 3-6.5. Труба отвода воздуха не должна располагаться рядом с дренажным насосом внутреннего блока.

Рисунок 3-6.3: Подключение соединительных трубопроводов к общему дренажному трубопроводу



Рисунок 3-6.4: Оседание трубопровода в результате некачественно установленных опор



Рисунок 3-6.5: Угольник для отвода воздуха

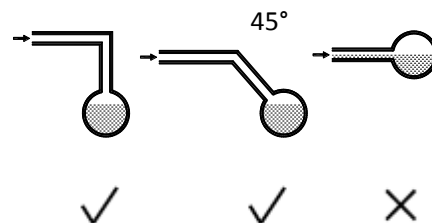

- Дренажный трубопровод должен быть изолирован от трубопроводов для сточной или дождевой воды, конец дренажного трубопровода не должен касаться земли.
- Диаметр дренажного трубопровода должен соответствовать диаметру переходника для дренажного трубопровода внутренних блоков.
- При подсоединении дренажного трубопровода к внутреннему блоку используйте хомут для трубопровода, включенный в комплект с блоком. Использование клея для подсоединения запрещено с целью облегчения профилактического обслуживания в будущем.
- Теплоизолируйте дренажный трубопровод во избежание образования конденсата на поверхности. Теплоизоляция должна быть произведена сразу после подсоединения трубопровода к внутреннему блоку.
- Внутренние блоки, оснащенные дренажным насосом, должны иметь трубопроводы, отдельные от трубопроводов, осуществляющих дренаж самотёком.

6.2 Дренажный гидрозатвор

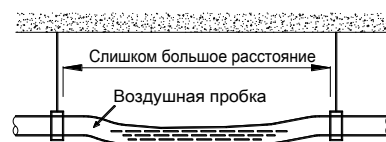
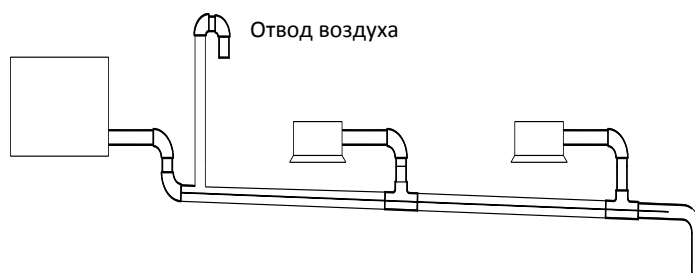
Для внутренних блоков с разрежением воздуха на выходе дренажного патрубка, дренажный трубопровод должен быть оснащен гидрозатвором, обеспечивающим перекрытие разрежения воздуха через дренажный трубопровод и способствующим беспрепятственному удалению конденсата из дренажного поддона. Установите гидрозатворы для дренажного трубопровода, как показано на Рисунке 3-6.6. Перепад высот H должен составлять не менее 50 мм. Во время монтажа обеспечьте легкий доступ для проведения профилактических работ по очистке колена гидрозатвора, для этого установите пробку.

Рисунок 3-6.6: Дренажный гидрозатвор

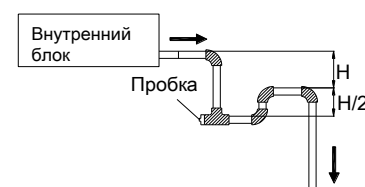

6.3 Подбор диаметра трубопроводов

Подберите диаметры соединительных трубопроводов для подключения к каждому внутреннему блоку согласно объему потока конденсата от каждого блока и диаметр общего дренажного трубопровода согласно суммарному объему потока конденсата от внутренних блоков. Для расчёта используйте расход 2 л/ч для одного блока 1 л.с.. Так, суммарный объем потока конденсата для трёх блоков 2 л.с. и двух блоков 1,5 л.с. будет рассчитываться следующим образом:

$$\begin{aligned} \text{Суммарный объем} &= 3 \times 2 \text{ л/л.с./ч} \times 2 \text{ л.с.} &&= 18 \text{ л/ч} \\ \text{потока конденсата} &+ 2 \times 2 \text{ л/л.с./ч} \times 1,5 \text{ л.с.} \end{aligned}$$

В Таблицах 3-6.1 и 3-6.2 указаны диаметры горизонтального и вертикального трубопроводов по отношению к допустимому расходу конденсата.

Примечание: Требуется пайка для труб PVC40 и более.

Таблица 3-6.1: Соотношение между диаметром горизонтального трубопровода и допустимым расходом конденсата

ПВХ труба	Внутренний диаметр трубопровода (исходное значение), мм	Допустимый расход, л/ч		Примечание
		Уклон 1:50	Уклон 1:100	
PVC25	25	39	27	(Исходная величина) не может использоваться для общего трубопровода
PVC32	32	70	50	
PVC40	40	125	88	
PVC50	50	247	175	Может использоваться для объединенного трубопровода
PVC63	63	473	334	

Таблица 3-6.2: Соотношение между диаметром вертикального трубопровода и допустимым расходом конденсата

ПВХ труба	Внутренний диаметр трубопровода (исходное значение), мм	Допустимый расход, л/ч	Примечание
PVC25	25	220	(Исходная величина) не может использоваться для общего трубопровода
PVC32	32	410	
PVC40	40	730	Может использоваться для объединенного трубопровода
PVC50	50	1440	
PVC63	63	2760	
PVC75	75	5710	
PVC90	90	8280	

6.4 Монтаж дренажного трубопровода с подъемом для блоков с дренажным насосом

Для блоков с дренажным насосом при монтаже дренажного трубопровода с подъемом обратите особое внимание на следующие пункты:

- После завершения монтажа трубопровода немедленно наклоните его вниз, иначе может возникнуть неисправность при работе дренажного насоса. См. Рисунок 3-6.7.
- Труба для выхода воздуха не может находиться на участке подъема; в обратном случае выход воды будет невозможен либо вода попадет на потолок.

Рисунок 3-6.7: Изображение дренажного трубопровода с подъемом



6.5 Порядок монтажа общего дренажного трубопровода

Примечания для специалистов по монтажу

Монтаж общего дренажного трубопровода должен осуществляться в следующем порядке:

Установите внутренний блок

Подключите дренажный трубопровод

Проведите проверку на утечку конденсата

Теплоизолируйте дренажный трубопровод

Осторожно

- После завершения монтажа дренажа убедитесь в надёжности всех соединений и проведите испытание на утечку конденсата для проверки дренажного трубопровода на отсутствие утечек воды.
- Дренажный трубопровод должен быть изолирован от трубопроводов для сточной или дождевой воды, конец дренажного трубопровода не должен касаться земли.
- Проверьте работу дренажного насоса и эффективность слива конденсата. Для этого медленно залейте воду в дренажный поддон и включите блок. При подсоединении дренажного трубопровода к внутреннему блоку используйте хомут для трубопровода, включенный в комплект с блоком. Использование клея для подсоединения запрещено с целью облегчения профилактического обслуживания в будущем.

6.6 Проверка на утечку конденсата из дренажной системы трубопроводов

После завершения монтажа дренажного трубопровода проведите испытание на утечку конденсата для проверки дренажного трубопровода на отсутствие утечек воды.

Примечания для специалистов по монтажу

Проверка на утечку конденсата

- Залейте воду в трубопровод и оставьте на протяжении 24 часов для проверки мест соединений на отсутствие утечек.

Проверка работы дренажной системы трубопроводов (Проверка слива конденсата самотеком)

- Медленно добавляйте воду в дренажный поддон в объеме около 600 мл через контрольное отверстие, проверьте слив конденсата и герметичность трубопроводов.

Осторожно

- Пробка для дренажа в поддоне предназначена для удаления воды во время технического обслуживания кондиционера. Во время эксплуатации блока дренажный выход должен быть перекрыт пробкой во избежание утечек.

7. Теплоизоляция

7.1 Теплоизоляция трубопровода хладагента

7.1.1 Цель

Во время эксплуатации температура трубопровода хладагента будет чрезмерно повышаться или понижаться. Поэтому необходимо обеспечить теплоизоляцию трубопроводов хладагента с целью защиты производительности блока и продления срока службы компрессора. Температура газового трубопровода сильно понижается в режиме охлаждения. При отсутствии надежной теплоизоляции может образоваться конденсат, что приведет к утечкам. Температура газового трубопровода сильно повышается в режиме обогрева (до +100°C). В данном случае изоляция необходима в качестве защиты от потери тепла и для защиты от перегрева.

7.1.2 Подбор теплоизоляционных материалов для трубопроводов хладагента

Примените вспененный полипропилен, с закрытыми порами в качестве теплоизоляционного материала с классом огнестойкости В1 и защитой от воздействия высокой температуры до +120 °С.

7.1.3 Толщина теплоизоляционного слоя

Минимальная толщина теплоизоляционного слоя трубопровода хладагента должна соответствовать значениям, указанным в Таблице 3-7.1. В помещениях с повышенной температурой и высоким уровнем влажности воздуха значения, указанные в Таблице 3-7.1, должны быть увеличены в два раза.

Таблица 3-7.1: Толщина теплоизоляционного слоя трубопровода хладагента

Наружный диаметр трубопровода (мм)	Минимальная толщина теплоизоляционного слоя (мм) при относительной влажности воздуха < 80%	Минимальная толщина теплоизоляционного слоя (мм) при относительной влажности воздуха ≥ 80%
Ф6,35	15	20
Ф9,53		
Ф12,7		
Ф15,9		
Ф19,1		
Ф22,2		
Ф25,4		
Ф28,6		
Ф31,8		
Ф38,1	20	25
Ф41,3		
Ф44,5		
Ф54,0		

7.1.4 Монтаж и основные требования к изоляции частей агрегата

Теплоизоляция трубопровода хладагента, не включая соединения и швы, должна быть произведена до монтажа. Теплоизоляция швов должна быть произведена после испытаний на герметичность.

Примечания для специалистов по монтажу

- Теплоизоляция частей внутреннего блока трубопроводов должна соответствовать основным требованиям и методам по изоляции агрегатов данного типа. Во время обработки должны учитываться особенности выбранного теплоизоляционного материала.
- Убедитесь, что в местах соединений теплоизоляционных материалов отсутствуют зазоры.
- Используйте любую изоляционную ленту, оказывая на нее соответствующее давление во время обматывания. При чрезмерном перетяжении лента может ослабнуть и потерять свои изоляционные свойства, что приведет к утечкам конденсата и снижению производительности.
- Газовый и жидкостный трубопроводы должны быть изолированы по отдельности, в противном случае производительность и эффективность агрегата значительно снижаются.
- После обеспечения отдельной изоляции газового и жидкостного трубопроводов не пережимайте место теплоизоляционного соединения во избежание повреждений.

7.1.5 Теплоизоляция соединений

Теплоизоляция соединений и швов должна быть произведена после испытаний на герметичность. Порядок проведения работ по теплоизоляции соединений описан ниже:

1. Отрежьте теплоизоляционный материал длиной, превышающей размер зазора на 50 – 100 мм. Расправьте оба конца теплоизоляционного материала и выровняйте его сечение.
2. Вставьте теплоизоляционный материал в зазор, после чего плотно прижмите область его сечения.
3. Проклейте соединение, все отрезанные участки изоляционного материала должны быть проклеены.
4. Обвяжите обработанный участок виниловой лентой.

Рисунок 3-7.1: Теплоизоляция соединений (Единица измерения: мм)

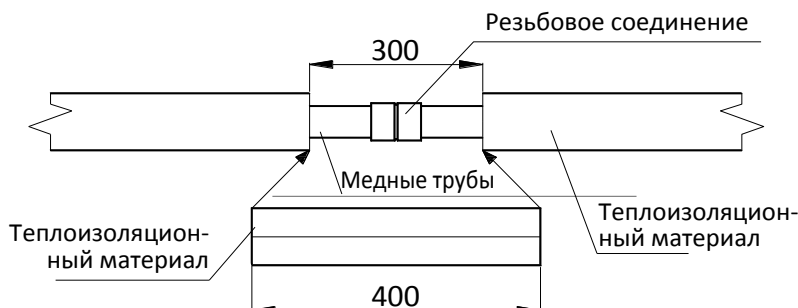

7.2 Теплоизоляция дренажного трубопровода

- Подберите резиновую или ПВХ ленту с классом огнеупорности В1.
- Стандартная толщина теплоизоляционного слоя должна быть не менее 10 мм.
- Для дренажного трубопровода настенного блока допускается не использовать теплоизоляцию.
- Используйте специальный клей для изоляции стыков изоляционного материала, а затем обмотайте данный участок виниловой лентой. Ширина ленты должна составлять не менее 50 мм. Убедитесь, что лента надежно закреплена на месте во избежание образования конденсата и утечек.
- Изоляционный материал для дренажной трубы должен быть приклеен с помощью клея к корпусу блока во избежание образования конденсата и утечек.

7.3 Теплоизоляция воздуховодов

- Изоляция воздуховодов должна быть произведена в соответствии с нормами действующего законодательства.

8. Заправка дополнительного количества хладагента

8.1 Порядок работ при проведении дозаправки хладагента

Заправка дополнительного количества хладагента рассчитывается по длинам и диаметрам жидкостных трубопроводов внутренних и наружных блоков. В Таблице 3-8.1 указан вес добавляемого хладагента на метр эквивалентной длины трубопроводов различных диаметров. Общий вес добавляемого хладагента представляет собой суммарный вес, необходимый для дозаправки всех жидкостных трубопроводов внутренних и наружных блоков. Формула для расчета веса указана ниже, где L₁ - L₈ представляют эквивалентные длины трубопроводов различных диаметров. Эквивалентная длина трубопровода разветвителя составляет 0,5 м (для расчета).

$$\begin{aligned} \text{Вес добавляемого хладагента: } R \text{ (кг)} = & L_1 (\Phi 6,35) \times 0,022 \\ & + L_2 (\Phi 9,53) \times 0,057 \\ & + L_3 (\Phi 12,7) \times 0,110 \\ & + L_4 (\Phi 15,9) \times 0,170 \\ & + L_5 (\Phi 19,1) \times 0,260 \\ & + L_6 (\Phi 22,2) \times 0,360 \\ & + L_7 (\Phi 25,4) \times 0,520 \\ & + L_8 (\Phi 28,6) \times 0,680 \end{aligned}$$

Таблица 3-8.1: Вес хладагента для дозаправки

Диаметр жидкостного трубопровода (мм)	Вес добавляемого хладагента на метр эквивалентной длины трубопровода (кг)
Φ6,35	0,022
Φ9,53	0,057
Φ12,7	0,110
Φ15,9	0,170
Φ19,1	0,260
Φ22,2	0,360
Φ25,4	0,520
Φ28,6	0,680

8.2 Дозаправка хладагента

Примечания для специалистов по монтажу

Осторожно

- Убедитесь в эффективности осушения с вакуумированием перед дозаправкой хладагента.
- Никогда не заправляйте хладагент в количестве, превышающем указанную норму, так как это может привести к гидроудару.
- Используйте только хладагент R410A. Во избежание взрыва и травм заправка неподходящим хладагентом категорически запрещена.
- Используйте приборы и оборудование, совместимые с хладагентом R410A, для обеспечения требуемого гидравлического сопротивления и предотвращения попадания посторонних материалов в систему.
- Хладагент должен применяться в соответствии с действующим законодательством.
- Всегда используйте элементы спецодежды, такие как защитные перчатки и очки, при заправке хладагента.
- Соблюдайте осторожность при обращении с баллонами с хладагентом, открывайте их медленно и аккуратно.

Процесс дозаправки хладагента

Процесс дозаправки хладагента описан ниже:

Этап 1

- Рассчитайте вес дополнительного хладагента R (кг) (См. пункт 8.1 Части 3 данного руководства “Заправка дополнительного количества хладагента”)

Этап 2

- Используйте электронные весы для измерения веса хладагента, для этого поместите баллон с хладагентом на весы. Переверните баллон вверх дном, чтобы убедиться, что хладагент заправляется в жидкой фазе. (R410A представляет собой смесь двух разных химических соединений. Если заправляемый хладагент будет иметь газообразную форму, то это может привести к изменению состава хладагента).
- После завершения процесса вакуумирования (См. Часть 3, п. 5.9 «Вакуумирование») синий и красный шланги должны оставаться подключёнными к манометру и газовому и жидкостному вентилям наружного блока.
- Подсоедините желтый шланг от манометра к баллону с хладагентом R410A.

продолжение на следующей странице...

Этап 3

- Откройте вентиль в месте подсоединения желтого шланга к манометру и слегка приоткройте баллон с хладагентом, чтобы удалить воздух из шлангов. Осторожно: медленно открывайте баллон во избежание обморожения рук.
- Установите весы на ноль.

Этап 4

- Откройте два вентиля на манометре, чтобы начать заправку хладагента в жидкостной трубопровод.
- Когда заправленное количество хладагента достигнет значения R (кг), закройте вентили. Если заправленное количество не достигло значения R (кг) и при этом дальнейшая дозаправка невозможна, закройте два вентиля, запустите наружный блок в режиме охлаждения, а затем откройте вентили для желтого и синего шланга. Продолжайте процесс дозаправки, пока не будет достигнуто значение R (кг), после чего закройте вентили желтого и синего шланга.

Примечание: Перед запуском системы обязательно выполните все предварительные проверки для ввода в эксплуатацию, как указано в Части 3, п. 11.3 «Пусконаладочные работы для ввода в эксплуатацию», и обязательно откройте все запорные вентили. При работе наружного блока с закрытыми запорными вентилями будет поврежден компрессор.

Рисунок 3-8.1: Заправка хладагента

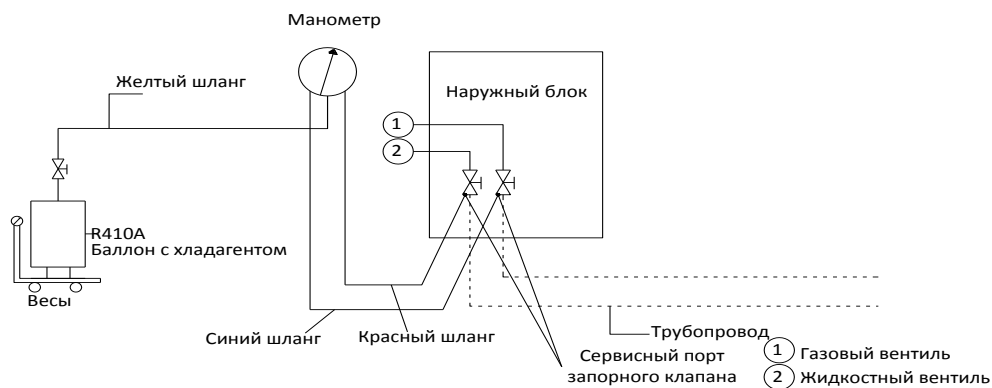

Манометр

9. Монтаж электрических соединений

9.1 Общие требования к монтажу электрических соединений

Примечания для специалистов по монтажу

Осторожно

- Монтаж линий электропитания и связи должен осуществляться только квалифицированными специалистами в соответствии с действующим законодательством.
- Пожалуйста, соблюдайте все требования и правила по заземлению агрегата, предусмотренные соответствующими местными законами и стандартами.
- Схема электропитания должна включать УЗО и защитные автоматы или предохранители.
- Схемы подключения в настоящем руководстве представлены только для общего ознакомления. При монтаже всегда руководствуйтесь только фактическими исходными данными агрегата.
- Сеть трубопроводов хладагента, линия электропитания и линия связи между внутренними и наружным блоками должны быть от одного холодильного контура. Не допускается кросс-соединение! Не размещайте кабели силовые и линии связи в одном канале; если потребляемый ток составляет менее, чем 10 А, кабели должны быть разнесены на расстояние более 300 мм, если потребляемый ток составляет от 10 А до 50 А, расстояние должно быть увеличено до 500 мм.

9.2 Схема электропитания

Монтаж линий электропитания должен соответствовать следующим требованиям:

- Внутренние и наружные блоки должны иметь отдельные источники электропитания.
- Если установлено пять или более наружных блоков, установите УЗО (устройство защитного отключения), как показано на Рисунке 3-9.1.
- Ввод электропитания, УЗО, защитные автоматы или предохранители всех внутренних блоков, подключенных к одному наружному блоку, должны быть общими, как показано на Рисунке 3-9.2. Не устанавливайте УЗО и защитные автоматы отдельно для каждого внутреннего блока. Включение и отключение электропитания всех внутренних блоков, подключенных к одному наружному блоку, должно осуществляться одновременно на всех блоках для обеспечения долгого срока службы системы. Это необходимо, так как если работающий внутренний блок внезапно выключится, а остальные внутренние блоки продолжат работать, испаритель выключенного блока начнёт обмерзать, поскольку хладагент продолжит поступать в этот блок (его расширительный вентиль все еще будет открытым), но при этом его вентилятор отключится. Внутренние блоки, которые продолжают работать, не получают достаточное количество хладагента, что приведёт к снижению их производительности. Кроме того, жидкий хладагент, возвращающийся непосредственно в компрессор из выключенного блока, может привести к гидроудару, в результате чего компрессор будет повреждён.
- Для подбора силового кабеля наружного блока и УЗО см. Таблицу 2-6.1 в Части 2, п. 6 «Электрические характеристики».

Рисунок 3-9.1: Схема электропитания для наружных блоков



Рисунок 3-9.2: Схема электропитания для внутренних блоков



Примечания для специалистов по монтажу

Используйте трёхфазный источник питания 380-415 В, 50 или 60 Гц для подключения к клеммам электропитания наружного блока, как показано на рисунке 3-9.3.

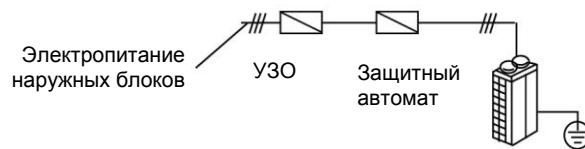
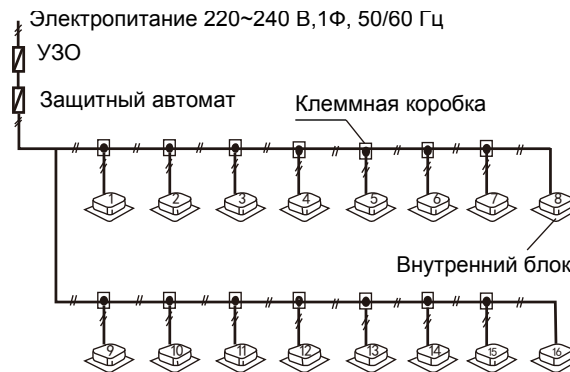
Рисунок 3-9.3: Клеммы электропитания наружного блока

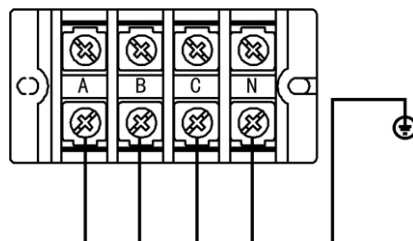

9.3 Монтаж линий связи

Монтаж линий связи должен соответствовать следующим требованиям:

- Кабель связи между внутренними и наружным блоками должен быть экранированным, 3-х жильным (0,75 мм²). Использование других проводов будет создавать помехи для сигнала, что приведет к неисправности.
- **Подключение линии связи к внутренним блокам:**
 - Кабели связи PQE должны быть подсоединены к каждому блоку последовательно от наружного блока до последнего внутреннего блока. Последний внутренний блок должен иметь подключение с резистором 120 Ом между P и Q. Линия связи не должна образовывать замкнутый контур.
 - Не заземляйте провода связи P и Q.
 - Экранированные сетки на двух сторонах экранированных кабелей должны быть соединены друг с другом при подключении во внутренних блоках, и заземлены со стороны наружного блока только. Заземление может быть обеспечено путем подключения к металлическому корпусу электрического блока управления наружного блока рядом с клеммами PQE.

Примечания для специалистов по монтажу 

Кабель связи должны быть подключены к клеммам наружного блока, указанным на Рисунке 3-9.4 и в Таблице 3-9.1.

Осторожно

- Линия связи имеет полярность, поэтому будьте осторожны при подключении

Рисунок 3-9.4: Клеммы связи наружного блока



Таблица 3-9.1: Инструкция по подключению к электрическим клеммам

Terminals	Connection
O A E	Учет энергопотребления
X Y E	Центральное управление внутренними блоками
P Q E	Линия связи наружный - внутренние блоки
H1 H2 E	Недоступно для наружных блоков серии MVS FDCII-S

Dantex MVS FDC II-S серия. Техническая инструкция

9.4 Пример подключения линий связи и электропитания

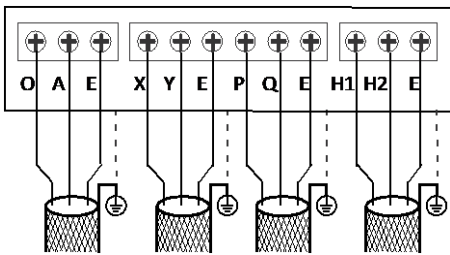
Рисунок 3-9.5: Пример подключения линий связи и электропитания

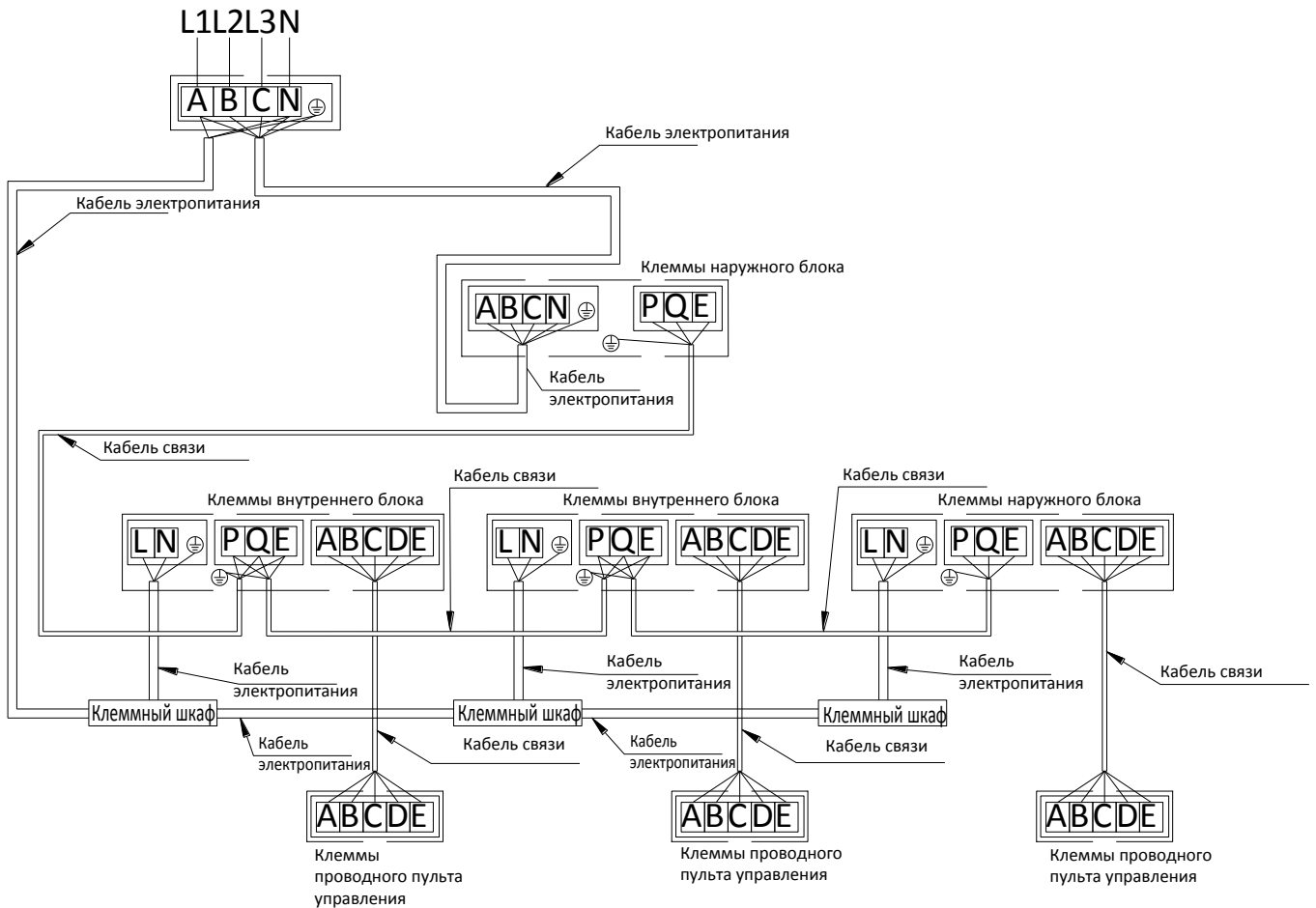

10. Монтаж в местах с высокой концентрацией солей в воздухе

10.1 Осторожно

Запрещается устанавливать наружные внутренние блоки в местах, непосредственно подвергаемых воздействию морского ветра (соленого ветра). Это может привести к коррозии конденсатора и оребрения испарителя, может привести к поломке и снижению производительности.

Если наружный блок установлен рядом с прибрежной морской полосой, он должен быть надежно защищен от непосредственного воздействия соленого морского ветра. Также, блокам потребуется дополнительное антикоррозионное покрытие. Иначе срок службы наружного блока значительно сократится.

Кондиционеры, установленные рядом с морем, должны регулярно работать, так как работающие вентиляторы наружного блока помогают предотвратить скапливание соли на теплообменниках наружного блока.

10.2 Требования к месту для монтажа

Если предполагается монтаж блока в прибрежной морской зоне, расстояние между наружным блоком и прибрежной морской полосой должно быть более 300 м. Пожалуйста, устанавливайте наружные блоки в хорошо проветриваемом помещении и используйте воздуховоды для удаления нагретого воздуха. Воздуховоды должны быть изготовлены на месте установки блока. См. Часть 3, п. 3 «Монтаж воздуховодов для наружных блоков». См. Рисунок 3-10.1. Если наружный блок установлен снаружи здания, избегайте непосредственного воздействия соленого морского ветра на блок. Предусмотрите защиту блока в виде навеса на расстоянии более двух метров от верхней части наружного блока. Также учитывайте, что навес не должен подвергаться непосредственному воздействию морского ветра и дождя, как показано на Рисунке 3-10.2.

Убедитесь в исправности дренажа основной части системы, запрещено погружение основания наружного блока в воду. Убедитесь, что дренажные отверстия основания наружного блока не засорены.

Рисунок 3-10.1: Монтаж в хорошо проветриваемом закрытом помещении

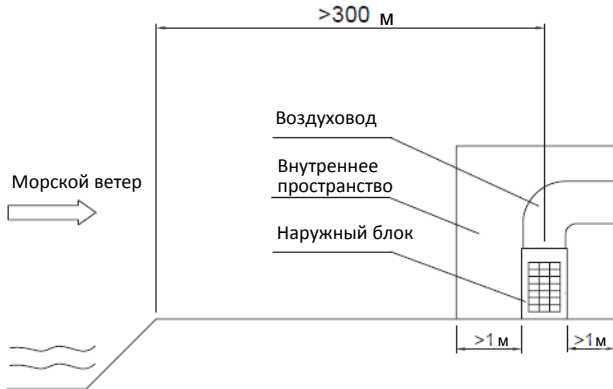
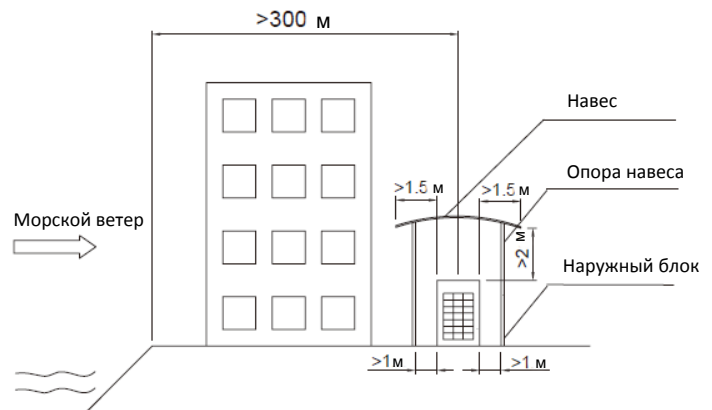

Figure 3-10.2: Installation outdoors under a canopy



10.3 Проверка и обслуживание

В дополнение к стандартным процедурам по обслуживанию и ремонту наружных блоков, установленных рядом с морем, необходимо провести следующие дополнительные проверки и техническое обслуживание:

- После монтажа необходимо провести тщательный осмотр системы. При наличии повреждений или царапин, пожалуйста, незамедлительно восстановите лакокрасочное покрытие.
- Для удаления солей и коррозионных веществ, пожалуйста, используйте воду (водопроводная вода или другая чистая вода) для проведения регулярной профилактической очистки поверхности наружного блока (включая конденсатор, наружную поверхность системы трубопроводов, наружную поверхность металлической пластины и шасси, наружную поверхность электрического блока управления).
- Регулярно проверяйте состояние наружного блока. При необходимости повторно проведите обработку от коррозии и замените неисправные и поврежденные компоненты системы.

11. Пусконаладочные работы для ввода в эксплуатацию

11.1 Настройки производительности наружных блоков

Производительность каждого наружного блока (настройка DIP-переключателя ENC2 на основной плате управления каждого наружного блока) устанавливается на заводе и не может быть изменена пользователем самостоятельно. Проверьте правильность настроек производительности. См. Таблицу 3-11.1.

Таблица 3-11.1: Настройки производительности наружного блока

Настройки производительности наружного блока				
0	8 л.с.		7	22 л.с.
1	10 л.с.		8	24 л.с.
2	12 л.с.		9	26 л.с.
3	14 л.с.		A	28 л.с.
4	16 л.с.		B	30 л.с.
5	18 л.с.		C	32 л.с.
6	20 л.с.			

11.2 Проекты с несколькими системами хладагента

Перед одновременным вводом всех систем хладагента в эксплуатацию пусконаладочные работы должны быть проведены для каждого независимого контура по отдельности (то есть для каждой системы, состоящей из одного наружного блока и подключённых к нему внутренних блоков).

11.3 Проверка и подтверждение перед пусконаладочными работами

Перед включением питания внутреннего и наружного блоков убедитесь в следующем:

1. Убедитесь, что сеть трубопроводов хладагента, линия связи между внутренними и наружным блоками P, Q, E от одного холодильного контура во избежание неисправностей. Запишите наименование подключенной системы и наименования внутренних блоков для каждой системы в паспортных данных, расположенных на крышке электрического блока управления наружным блоком.
2. Проверьте, была ли произведена очистка трубопровода, а также были ли проведены испытание на герметичность и вакуумирование в соответствии с инструкциями.
3. Весь конденсат должен быть удалён из системы дренажных трубопроводов, после чего было проведено испытание на герметичность.
4. Проверьте, правильно ли подключены линии электропитания и связи к соответствующим клеммам на блоках и пультах управления. (Убедитесь, что различные фазы 3-фазных источников питания подключены к клеммам правильно).
5. Перед подключением к сети электропитания убедитесь в отсутствии коротких замыканий.
6. Проверьте, правильно ли подключены линии электропитания внутренних и наружных блоков. Напряжение электропитания должно находиться в пределах допустимого диапазона $\pm 10\%$ от расчетного напряжения.
7. Кабель связи между внутренними и наружным блоками должен быть 3-х жильным (0,75 мм²) с заземлённым экранированием.
8. Все DIP - переключатели внутренних и наружных блоков должны быть настроены в соответствии с требуемой производительностью (см. Часть 3, п. 11.1 «Настройки производительности наружного блока»).
9. Необходимое количество хладагента для дополнительной дозаправки подготовлено согласно Части 3, п. 8 «Заправка дополнительного количества хладагента».

Примечание: В некоторых случаях может возникнуть необходимость запустить систему в режиме охлаждения во время процесса заправки хладагента. В таком случае перед запуском системы должны быть проверены пункты 1-8 выше, убедитесь, что газовый и жидкостный вентили наружного блока открыты.

При подготовке к пусконаладочным работам важно обеспечить следующее:

- Подготовьте необходимое количество хладагента для дополнительной дозаправки R410A.
- Приготовьте схемы трубопроводов и линий связи для системы.

11.4 Пусконаладочные работы для ввода в эксплуатацию

11.4.1 Пусконаладочные работы для ввода в эксплуатацию отдельной системы хладагента

После завершения всех предварительных проверок для ввода в эксплуатацию, описанных в Части 3, п. 11.3 «Проверка и подтверждение перед пусконаладочными работами», приступите к вводу системы в эксплуатацию, как описано ниже, и заполните отчет о пусконаладочных работах для системы серии V6-i. (См. Часть 3, п. 12 «Приложение к Части 3 - Отчет о пусконаладочных работах»).

Примечание: При пробном запуске системы если комбинационное соотношение составляет 100% или менее, запустите все внутренние блоки и, если коэффициент комбинации превышает 100%, запустите внутренние блоки с общей производительностью, равной производительности наружного блока.

Порядок ввода в эксплуатацию описан ниже:

1. Откройте газовый и жидкостный вентили наружного блока.
2. Подключите наружный блок к сети электропитания.
3. При ручной адресации установите адреса для всех внутренних блоков.
4. Включите защитные автоматы электропитания наружных блоков заранее и оставьте их включенными на 12 часов для предварительного подогрева холодильного масла.
5. Запуск системы:
 - a) Произведите запуск системы в режиме охлаждения при температуре +17°C и высокой скорости вращения вентилятора.
 - b) Убедитесь, что система работает непрерывно в течение не менее 1 часа, а затем заполните форму А Отчета о пусконаладочных работах. Далее проверьте системные параметры с помощью кнопки ВВЕРХ/ВНИЗ на главной плате управления наружным блоком и заполните столбцы режима охлаждения одной формы D и одной формы E Отчета о пусконаладочных работах для наружного блока.
 - c) Запустите систему в режиме обогрева со следующими настройками: температура воздуха +30 °C; скорость вращения вентилятора – высокая.
 - d) Убедитесь, что система работает непрерывно в течение не менее 1 часа, а затем заполните форму B Отчета о пусконаладочных работах. Далее проверьте системные параметры с помощью кнопки ВВЕРХ/ВНИЗ на главной плате управления наружным блоком и заполните столбцы режима обогрева одной формы D и одной формы E Отчета о пусконаладочных работах для наружного блока.
6. После завершения пусконаладочных работ заполните все пункты формы Отчета о пусконаладочных работах С.

11.4.2 Пусконаладочные работы для ввода в эксплуатацию комбинаторных наружных блоков

После успешного выполнения пусконаладочных работ для ввода в эксплуатацию каждой системы хладагента, как описано в Части 3, п. 11.4.1 «Пусконаладочные работы для ввода в эксплуатацию отдельной системы хладагента», запустите одновременно несколько систем, составляющих проект, и проверьте их на наличие каких-либо неисправностей.