

Si-27

PISTON PUMP



Versatile technology

The Si-27 is suitable for air-conditioning units up to 20 kW. The piston technology is specifically designed for removing condensates from air conditioning systems. The Si-27 is fully reliable in any kind of environment and its sound level remains quiet regardless of the condensate volume.

BENEFITS



● Patented technology

High performance: only one pump is needed for air conditioning units up to 20 kW.

Highly resistant to pollution created by general environments and capable of discharging small particles.

- **Proven reliability**



● Silent

- Low operating sound levels: quiet in operation (20 dBA independently tested).
- The size of the air-conditioning unit and volume of condensates to be removed does not affect the operational sound level of the pump.



● Easy to install

- **Mounting bracket:** allows the pump to be wall mounted or hung from ceilings and pipework.
- **Plug-in power cable** makes maintenance and replacement hassle free.
- **Safety switch**

● Energy saving

Improved performance and high flow rate **reduce operation time** and energy consumption.

KIT CONTENTS



- Piston pump
- Mounting bracket
- 1.5 m plug-in power cable
- 1.5m clear PVC tube Ø int 6 mm
- 6 tie wrap
- Detection unit (SI2958, 1.5m cable)
- Detection unit installation kit:
 - rubber hose Øint.15 x L 35 mm,
 - vent tube Ø int 4 x L 75 mm,
 - mounting rail,
 - adhesive.

APPLICATIONS

For use with any air-conditioning units, up to 20 kW:

- Wall mounted
- Ceiling suspended
- Ducted
- Fan-coils



TECHNICAL SPECIFICATION

Max. flow rate	20 l/h
Max. suction head	3 m
Max. discharge head	10 m (flow rate =4l/h)
Max pressure	14 m (flow rate =0l/h)
Sound level at 1m according to EN ISO 3744 (Measured at LNE lab, pump operating with water, out of application)	20 dBA
Mains supply	230V 50/60Hz 14W (SI27CE01UN23)
Insulation class	☐ (double insulation)
Detection levels	ON: 16mm, OFF: 11mm, Safety: 19mm
Safety switch	NC 8 A resistive – 250V
Thermal protection (overheating)	115°C (auto-reset)
Operating conditions	100% Continuous duty
Protection	IP20
Safety standards	CE / EAC
RoHS directive	Compliant
WEEE directive	Compliant
Packaging	0.48kg – L135 x W135 x H90 mm
Masterpack	20 pieces

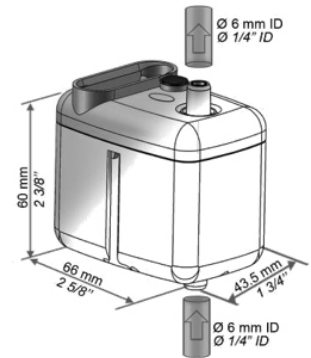
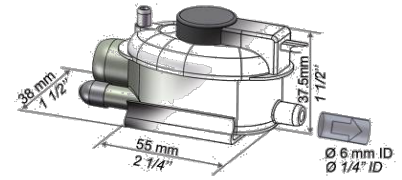

ACTUAL FLOW RATES (l/h)

Suction head (A)	Discharge head (B)	Total hose length using Ø int 6 mm, 1/4" – (C)			
		5 m	10 m	20 m	30 m
0 m	0 m	20	19	18	17
	2 m	16	15	14	13,5
	4 m	11,5	11	10,5	10
	6 m		8,5	7,5	6,5
	8 m		6	5	4
1 m	0 m	14	13	12	11
	2 m	11	10	9	8
	4 m	7,5	7	6	5
	6 m		4,5	4	
2 m	0 m	11	10	9	8
	2 m	9	8	7	6
3 m	0 m	10,5	9	8	7
	2 m	8	7	6	5
	4 m		5	4	

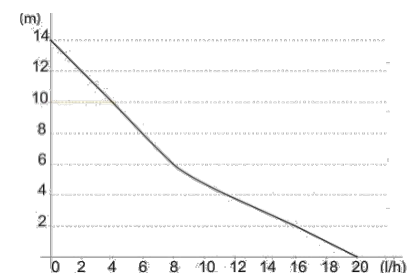
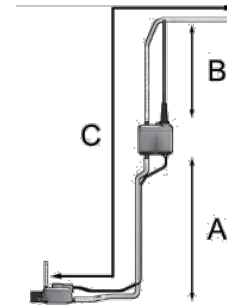

RECOMMENDED ACCESSORIES

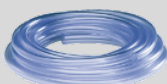

Clear PVC hose Ø int. 6mm (1/4")
 ACC00909 : 5 m
 ACC00910 : 50 m



6 Self-sealing fittings for hose
 Ø int. 6 mm (1/4")
 ACC00919



Drain Safe Devices for hose Ø int. 6 mm (1/4")
 ACC00922